

Gridley Planning Commission – Regular Meeting Agenda

Wednesday, April 17, 2024; 6:00 pm
Gridley City Hall, 685 Kentucky Street, Gridley, CA 95948

“Our purpose is to continuously enhance our community’s vitality and overall quality of life. We are committed to providing high quality, cost-effective municipal services and forming productive partnerships with our residents and regional organizations. We collectively develop, share, and are guided by a clear vision, values, and meaningful objectives.”

The Public is encouraged to attend and participate in person. Comments from the public on agenda items will be accepted until 4 pm on April 17th, 2024, via email to csantana@gridley.ca.us or via the payment/document drop box at Gridley City Hall and will be conveyed to the Commission for consideration.

You may view using the following link, ID, and passcode:

<https://us06web.zoom.us/j/89079304227?pwd=J1ifu6ttq1PVFVPjYTFH-5cEU1OdPA.S0Y50HZgOdTCmKtp>

Webinar ID: 890 7930 4227

Passcode: 779068

Or Telephone:

+1 669 444 9171 US

+1 719 359 4580 US

CALL TO ORDER – Chair Espino

ROLL CALL

COMMUNITY PARTICIPATION FORUM - Members of the public may address the Planning Commission on matters not listed on the agenda. The Planning Commission may not discuss nor act on any community participation item brought forward by a member of the community. Comments are requested to be limited to three (3) minutes.

CONSENT AGENDA

1. Planning Commission Minutes Dated November 15, 2023 and January 17, 2024

PUBLIC HEARING

2. Site Development Plan Review 1-24; Dutch Bros; Proposed development of approximately 1.06-acre parcel for a commercial development consisting of a single 950 square foot structure, 17 parking spaces, and landscaped open space. The General Plan land use designation is Commercial and zoned General Commercial (C-2) located on the east side of Highway 99. (APN 024-260-096)

3. Housing Element Update 2022-2030

CITY STAFF AND COMMISSION INFORMATIONAL UPDATES

ADJOURNMENT – Adjourning to the next regularly scheduled meeting on May 15th, 2024. This agenda was posted on the public bulletin board at City Hall at or before 6:00 p.m. on April 14th, 2024. This agenda along with all attachments, if any, is available for public viewing online at www.gridley.ca.us and/or at the Administration Counter in City Hall, 685 Kentucky Street, Gridley, CA. This is a public meeting, and anyone may address the Planning Commission. Any documents that were provided to the Planning Commission after the Agenda packet was distributed are also available for public review during normal business hours.

Meeting facilities are accessible to persons with disabilities. By request, alternative agenda document formats are available to persons with disabilities. To arrange an alternative agenda document format or to arrange aid or services to modify or accommodate persons with a disability to participate in a public meeting, contact the City Clerk by calling 846-3631 (voice). This request should be received at least three working days prior to the meeting to accommodate your request.

Gridley Planning Commission – Regular Meeting Minutes

Wednesday, January 17th, 2023; 6:00 pm
Gridley City Hall, 685 Kentucky Street, Gridley, CA 95948

“Our purpose is to continuously enhance our community’s vitality and overall quality of life. We are committed to providing high quality, cost-effective municipal services and forming productive partnerships with our residents and regional organizations. We collectively develop, share, and are guided by a clear vision, values, and meaningful objectives.”

CALL TO ORDER

Chair Espino called the meeting to order at 6:00 pm.

ROLL CALL

Commissioner Members

Present: Jamison, Holland, Adams, Wolfe, Espino

COMMUNITY PARTICIPATION FORUM

Pat Coghlan, Gridley resident, objected to the meeting being held as he felt there were documents not shared with the public regarding the items for discussion.

CONSENT AGENDA - None

PUBLIC HEARING

1. **RZ 1-24;** An application to rezone property to add the Agricultural Overlay District zoning designation to allow commercial agricultural production until the residentially zoned property is developed. The site has a General Plan land use designation of Residential, Medium Density (5-8 du/ac) and an underlying zoning designation of Single-Family Residential District (R-1). The property is located on the east side of West Biggs Gridley Road, north and contiguous to the Heron Landing Subdivision. (APN 022-210-092)

City Planner Donna Decker presented the rezone for the referenced property and explained that there was currently has an approved subdivision map: Chandler Park Subdivision, and the rezone would allow the landowner to continue farming the land until they are able to begin development.

Susan Schor had concerns about the ag buffer shown on the Chandler Park Subdivision map.

Commissioner Holland made a motion to approve the recommendations per the staff report, the motion was seconded by Commissioner Adams.

ROLL CALL VOTE

Ayes: Holland, Adams, Espino, Wolfe, Jamison

Motion passed, 5-0

- 2. GPA No. 1-23; ZTA 1-23:** Discussion of a General Plan Amendment to modify various land use policies and implementation strategies related to incompatible land uses and implementing Land Use Implementation Strategy 5.3 to adopt an ordinance clarifying the agricultural buffer width between incompatible land uses.

Planner Decker presented the item and explained that this item was strictly public hearing for comments to be considered for the 2050 General Plan Update and informed the Planning Commission that the City will not be moving forward with an amendment of the agricultural setback at this time.

Chair Espino made a statement that she understands there are a lot of inconsistencies in our current General Plan and appreciates that the City plans to focus on correcting these in the 2050 General Plan update.

Carl Schohr, Gridley area farmer, shared concerns about safety with granting variances and changing land uses in the future after the General Plan update is adopted.

Rocky Donati, Butte County Planning Commission, informed the Commission that Butte County Planning Commission is set on the 300 ft setback.

Susan Schohr provided copies of the County ordinance related to setbacks and ag buffers.

Pat Coghlan, Gridley resident spoke in opposition of an ag buffer less than 300 ft.

CITY STAFF AND COMMISSION INFORMATIONAL UPDATES - None

ADJOURNMENT

With no other items left to discuss, Chair Espino adjourned to the next regular meeting scheduled for February 21, 2024.

Gridley Planning Commission – Regular Meeting Minutes

Wednesday, November 15th, 2023; 6:00 pm
Gridley City Hall, 685 Kentucky Street, Gridley, CA 95948

“Our purpose is to continuously enhance our community’s vitality and overall quality of life. We are committed to providing high quality, cost-effective municipal services and forming productive partnerships with our residents and regional organizations. We collectively develop, share, and are guided by a clear vision, values, and meaningful objectives.”

CALL TO ORDER

Vice Chair Wolfe called the meeting to order at 6:00 pm.

ROLL CALL

Commissioner Members

Present: Jamison, Holland, Adams, Wolfe

Absent: Espino

COMMUNITY PARTICIPATION FORUM

The forum was opened, and seeing no one was present to speak, was closed.

CONSENT AGENDA - None

PUBLIC HEARING

1. **GPA No. 1-23; ZTA 1-23:** A General Plan Amendment to modify various land use policies and implementation strategies related to incompatible land uses and implementing Land Use Implementation Strategy 5.3 to adopt an ordinance clarifying the agricultural buffer width between incompatible land uses.

Planner Donna Decker presented the general plan amendment that would clarify and establish the agricultural buffer width between incompatible land uses.

Carl Schor, Gridley resident, shared concerns of using City of Chico as a comparison for establishing City of Gridley’s setback requirements. Susan Schor also shared her concerns for the reduction of the required setback.

Rocky Donati of the Butte County Planning Commission spoke to the Commission in opposition to the setback requirement being established at 100 ft.

Pat Coghlan, Gridley Resident, submitted written comments and had them read for the record in opposition to item #1.

Jerry Davis of Reclamation District 833 shared his concerns about communication between the City and neighboring entities.

- 2. Variance 2-23;** Application for a variance from the development standards to allow setback reductions within the multi-family R-3 zoning designation for a 1.48-acre site for the development of 19 residential units. The General Plan land use designation of Residential, High Density, 9-15 du/ac and a zoning designation Multi-Family Residential 9-15 du/ac on the east side of Haskell Street. (APN 010-210-043)

Planner Donna Decker requested approval of the variance that would allow a setback reduction for the proposed Parkland subdivision.

Jerry Davis of Reclamation District 833 shared concerns with drainage. Planner Decker informed him that the storm drain calculations were created by Robertson Erickson Engineering and was reviewed and approved by City of Gridley Public Works as well as the City Engineer.

Pat Coghlan, Gridley resident, shared concerns about access for fire vehicles. Motion to approve Variance 2-23 was made by Commissioner Holland, seconded by Commissioner Adams.

ROLL CALL VOTE

Ayes: Wolfe, Holland, Adams, Jamison

Motion passed, 4-0

CITY STAFF AND COMMISSION INFORMATIONAL UPDATES - None

ADJOURNMENT

With no further items left to discuss, Vice Chair Wolfe adjourned to the next regular meeting on December 20, 2023.

Planning Commission Item #2
Staff Report

Date: April 17, 2024
To: Chair and Planning Commissioners
From: Donna Decker, Planning Department

X	Regular
	Special
	Closed
	Emergency

Subject: **Site Development Plan Review 1-24;** Dutch Bros; Proposed development of approximately 1.06-acre parcel for a commercial development consisting of a single 950 square foot structure, 17 parking spaces, and landscaped open space. The General Plan land use designation is Commercial and zoned General Commercial (C-2) located on the east side of Highway 99. (APN 024-260-096)

Recommendation

It is recommended the Planning Commission:

1. Determine the project is Categorical Exempt per the California Environmental Quality Act, Section 15332(a-e), Class 32, Infill Development Projects; and,
2. Approve Site Development Plan Review 1-24.

Summary

The applicant has submitted an application to develop a site located on the east side of State Highway 99 north of the entry to the Sunrise Senior Apartments. The project will construct a 950 square foot structure to sell coffee and pastries as a walk up and drive-thru.

Discussion

Location

The subject site is an approximately 1.06-acre parcel located on the east side of State Highway 99 north of the driveway entry to the Sunrise Senior Apartments.

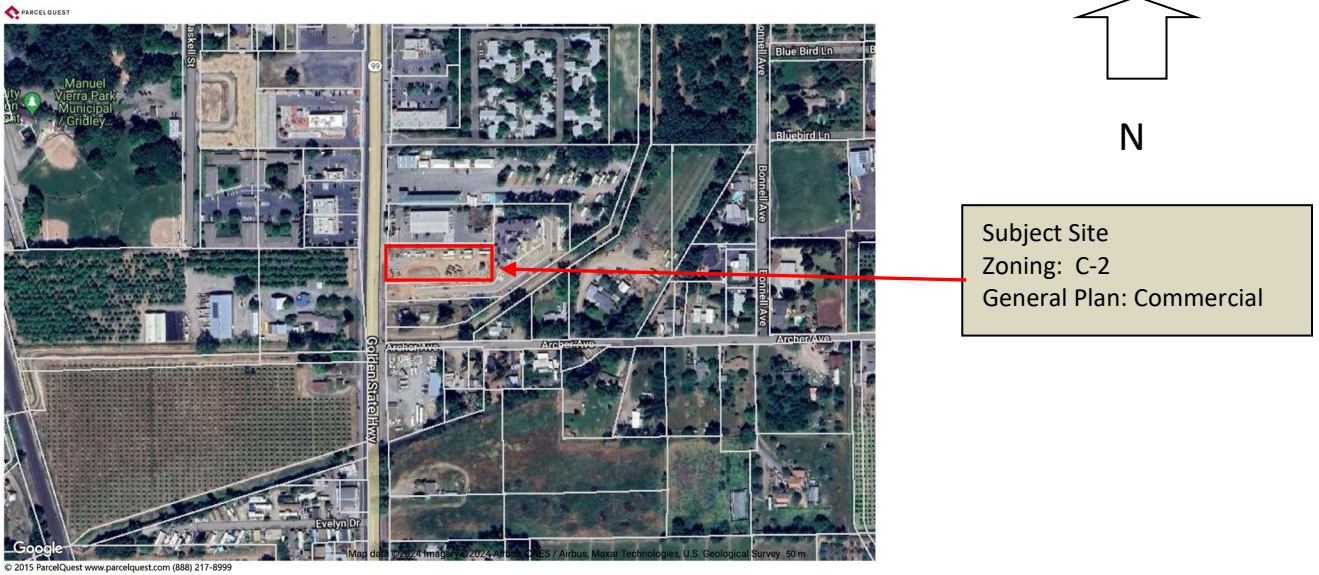

Figure 1: Location Map

General Plan and Zoning

The General Plan land use designation is Commercial; the zoning designation is C-2, General Commercial. The proposed project is to develop the site with a drive-thru coffee kiosk that sells coffee and pastries. This use is permitted in the zoning and general plan designation.

Site Design

The proposed development has one points of access from the joint driveway that serves the Sunrise Senior Apartments. This single access was a joint solution to the mission of Caltrans to limit the number of access points along the State Highway 99, thus increasing the safety along the corridor. The code requires curb, gutter and sidewalk (off-site improvements) to be constructed for all new projects (GMC Title 12, Streets, Sidewalks, and Public Places, Chapter 12.04, Installation of Curbs, Gutters and/or Sidewalks). The improvements will be constructed at the time the Caltrans SHOP project is constructed.

Building

The proposed 950 square foot building and a 1,515 covered area for outdoor seating. The is situated on the site to provide stacking in the drive-thru. The exterior is a combination of exterior cement plaster, fiber cement siding with columns and detailing of stone veneer.

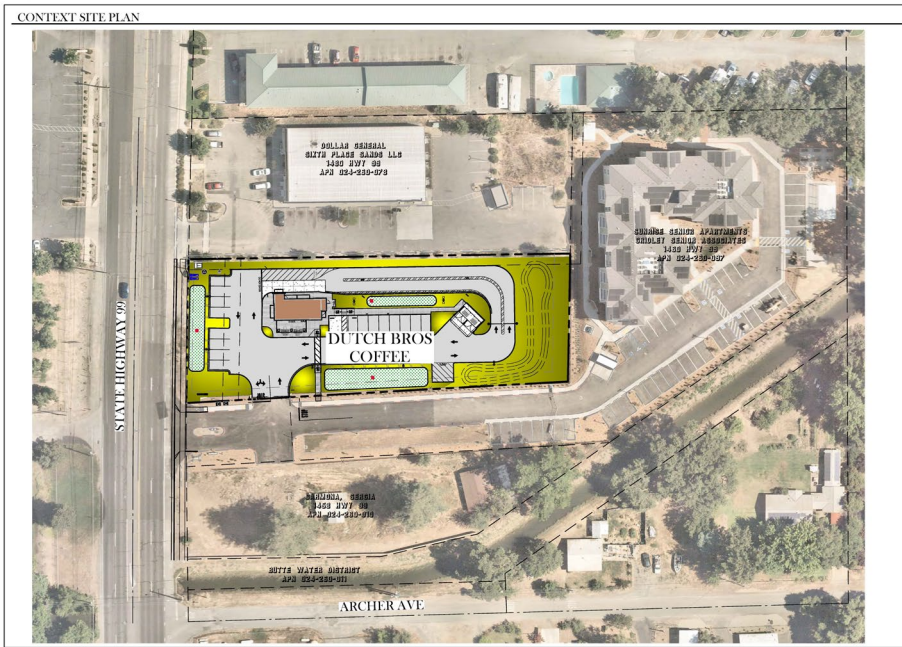

Figure 2: Site Plan and Rendering

Parking

The project requires a minimum of 1 space for every 3 seats that results in 12 parking spaces. The applicant has designed the site to provide 17 parking spaces. The parking spaces are in addition to the stacking. The site is adequate to handle additional parking should it be required or the site’s use intensified.

Landscaping

The applicant submitted a landscaping plan that will provide site shading and color in the landscape. The design will be able to meet the requirements of Chapter 13, Water Efficiency Ordinance.

Public Notice

A notice was posted in the Gridley Herald 10 days in advance of the Planning Commission meeting, posted at City Hall, made available at the Administration public counter, and placed on the City website for review and mailed to adjacent property owners 300 feet from the property boundary. At the time this report was prepared no comments had been received.

Environmental Review

The proposed project is categorically exempt from CEQA per Section 15332(a-e), Class 32, Infill Development Projects.

Attachments –

1. Exhibit A- Draft Conditions of Approval
2. Exhibit B- Project Plans

Exhibit A
DRAFT CONDITIONS OF APPROVAL
Site Development Plan Review No. 1-24
APN 024-260-096

Approved Use:

Site Development Plan review to construct a 950 square foot structure to serve coffee and pastries as a drive-thru site with 17 parking spaces.

Conditions of Approval:

General

1. The approved use for SDP 1-24 shall be substantially as described within this staff report, submitted site plans, narratives, and applications on file in City Hall except as modified by the following conditions. Minor changes to the use, areas, and etc. shall be subject to the review and approval by the Planning Department.
2. The applicant/property owner shall file a Declaration of Acceptance of the Final Conditions of Approval within 30 days of Planning Commission approval. The application shall expire one (1) year from the date of Planning Commission approval unless a building permit has been secured prior to the one (1) year date. If no permit has been secured, the applicant/owner or his/her successor may apply for an extension of the Site Development Plan review. The proposed extension will meet all current requirements at the time of the request and shall be reviewed and approved by the Planning Commission.
3. All construction shall be in accordance with all of the City of Gridley and the County of Butte currently adopted Building Codes; including but not limited to the Plumbing Code, Mechanical Code, Electrical Code, and the 2016 California Green Building Standards Code.
4. The applicant shall coordinate with the Gridley Municipal District Electrical Department for power supply. If natural gas will be installed, the applicant will need to coordinate with Pacific Gas & Electric.
5. Prior to construction, the applicant shall obtain an encroachment permit to work on City utilities within the state right-of-way. All work on utilities shall be coordinated with the Gridley Municipal Utility Department.
6. The exterior site lighting plan shall ensure that lighting is shielded or recessed to prevent direct glare and reflection is confined to the maximum extent possible to the site and does not go beyond the property boundaries. Exterior lighting shall be considerate of "Dark Sky" design and direct all lighting downward. Light foot-candles shall be at the lowest levels allowed and shall be placed on photovoltaic cells and sensor switches in conformance to the Green Building Code.
7. Decorative lighting in conformance to the City lighting requirements shall be provided and installed as determined by the City of Gridley Electrical Superintendent.
8. An application for site and building signage shall be submitted for review and approval by the Planning Department prior to placement on any structure or site location.
9. The property owner shall enter into a written agreement for the maintenance of the building, site, and site amenities, paving, and walkways in a form suitable for recordation with the Butte County Recorder binding upon the property owner and his/her successor(s) in interest. This agreement, at a minimum, shall state that all facilities and related equipment, including lighting, fences building facades, and materials shall be maintained in good repair, free from trash, debris, litter and graffiti, and other forms of vandalism, and any damage from any cause shall be repaired as soon as reasonably possible to minimize occurrences of dangerous conditions or visual blight. All pavement markings shall be maintained so as to be clearly visible throughout the life of the

development. Trash, debris, litter or graffiti shall be removed from the site and any facility or equipment as soon as practicable and in no instance more than forty-eight hours from the time of notification by the City. The agreement shall acknowledge that any costs incurred by City staff due to non-responsiveness by the owner or manager of the site will be the responsibility of the property owner not taken care of, the costs of any cleanup by City staff will be a fee born by the owner and his/her successor(s) in interest. Independent agreements shall be for the State and for the City of Gridley.

10. Outdoor refuse collection design shall comply with 17.72.100. A cover shall be provided the design of which shall be reviewed and approved by the Planning Department. If no refuse collection area is established, all containers shall be housed within the structure and not on the site.
11. A bicycle rack and a minimum of one enclosed bicycle storage area shall be provided.
12. Complete off-site improvements shall be designed, reviewed and approved by the City of Gridley City Engineer and Caltrans. Off-site improvements shall include the construction of curb, gutter, sidewalk, plan and profile of in right-of-way utilities being tied into (sewer, water, and storm drain, manholes as required), landscaping buffer, irrigation components, fire hydrants, and all electrical connections.
13. Plans for submittal shall comply with all Fire Department requirements. The applicant shall contact the City of Gridley Fire Department/CalFire for review and approval of site development plans and fire sprinkler systems through the building permit process. Clearly show the fire riser location on the plans for review and approval.
14. During construction, all Butte County Air Quality mitigation measures shall be complied with.
15. The siding type and style shall be as depicted on the plans and verified prior to installation.
16. Landscaping and irrigation plans meeting Chapter 13 of the Gridley Municipal Code shall be submitted for review and approval prior to building permit issuance.
17. Provide information related to the proposed fencing if any and obtain approval from the Planning Department prior to installation.

General Engineering Comments:

1. Provide a drainage plan that will satisfy the requirement that the peak post development flows do not exceed the peak predevelopment flows.
2. Show 100-year overland release to natural drainage in the event any onsite DI is plugged.
3. Vehicle overhang shall not infringe into any walkway limiting pedestrian access per Title 24. This may require parking bumpers in some areas.
4. Please verify that the building does not require fire suppression sprinklers. If so show where Fire service will be connected.
5. Provide a geotechnical report.
6. Provide a current Title Report.
7. Provide a legal description sufficient to define the boundary of the existing parcel.
8. Improvement plans will be required and be in conformance with the City of Gridley's requirements.
9. All work within the Caltrans ROW will require an encroachment permit from Caltrans.
10. All drainage and sewer lines shall be designed in accordance with the state water main separation requirements of Chapter 22 section 64572 of the California Code of regulations.
11. Prepare and submit final hydrology analysis.
12. Approval of the City Engineer is required prior to any onsite construction.
13. Approval of Reclamation District 2056 is required prior to any onsite construction.

14. Add the City of Gridley "Engineer of Work's Certificate" below to Civil Cover Sheet.

ENGINEER OF WORK'S CERTIFICATE I, _____, hereby declare that I am the Engineer of Work for this project, that I have exercised responsible charge over the design of the project as defined in Section 6703 of the Business and Professions Code, and the design is consistent with current standards of the City of Gridley and Special Districts having jurisdiction within the City. I understand that the check of project drawings and specifications by the City of Gridley and /or its contract City Engineer or their representative is confined to a review only and does not relieve me of responsibilities for project design. Signed _____ Date

_____ R.C.E. No. _____ Exp. _____

Firm _____ Telephone: _____

CALTRANS FRONTAGE IMPROVEMENTS

THESE SUBJECT PROJECT DEPICTS AND ASSUMES THAT IMPROVEMENTS BY STATE OF CALIFORNIA DEPARTMENT OF TRANSPORTATION AS PART OF THE STATE ROUTE 99 GRIDLEY PAVEMENT REHABILITATION PROJECT ARE COMPLETE AND IN PLACE. THESE IMPROVEMENTS ALONG THE SUBJECT PROPERTY FRONTAGE INCLUDE:

- PAVEMENT RESURFACING WIDENING
- CURB & GUTTER
- SIDEWALK
- STREET LIGHTS
- COMMERCIAL DRIVEWAY
- UTILITY IMPROVEMENTS

FEMA FLOOD ZONE:

ZONE X (0.2% ANNUAL CHANCE FLOOD HAZARD) PER FEDERAL EMERGENCY MANAGEMENT AGENCY FLOOD INSURANCE RATE MAP NO. 06007C1125E, EFFECTIVE 1/6/2011.

BASIS OF BEARING:

PARCEL MAP FILED FOR RECORD IN BOOK 103 OF MAPS, PAGES 73-74, BUTTE COUNTY RECORDS, BASED ON THE MONUMENTS SHOWN.

BENCHMARK:

NGS BENCHMARK PID KSI049, A DISK MARKED "M 381 1949" SET IN A RETAINING WINGWALL, 0.6 KM (0.35 MI) EAST ALONG HAZEL STREET FROM THE JUNCTION OF THE SOUTHERN PACIFIC RAILROAD IN GRIDLEY, THENCE 0.4 KM (0.25 MI) SOUTH ALONG STATE HIGHWAY 99, THENCE 0.5 KM (0.30 MI) EAST ALONG OROVILLE ROAD.
ELEVATION = 100.11 FEET (NAVD 88 DATUM).

PROPERTY LEGAL DESCRIPTION:

THE SURVEYED PROPERTY SHOWN HEREON IS SITUATED IN THE STATE OF CALIFORNIA, COUNTY OF BUTTE, CITY OF GRIDLEY AND DESCRIBED AS FOLLOWS:

BEING A PORTION OF SECTION 6, TOWNSHIP 17 NORTH, RANGE 3 EAST, MOUNT DIABLO BASE AND MERIDIAN, CITY OF GRIDLEY, COUNTY OF BUTTE, STATE OF CALIFORNIA BEING A PORTION OF PARCELS 2 AND 3 OF THE PARCEL MAP FILED IN BOOK 103 OF MAPS, PAGES 73-74, COUNTY OF BUTTE, STATE OF CALIFORNIA AND MORE PARTICULARLY DESCRIBED AS FOLLOWS:

BEGINNING AT A POINT ON THE WESTERLY LINE OF SAID PARCEL 2 FROM WHICH THE SOUTHEAST CORNER OF SAID PARCEL 3 BEARS SOUTH 01°01'09" WEST, 60.17 FEET; THENCE (1) SOUTH 86°46'02" WEST, 361.08 FEET TO THE WESTERLY LINE OF SAID PARCEL 3 BEING THE BEGINNING OF A CURVE TO THE RIGHT HAVING A RADIUS OF 14,950.00 FEET; THENCE (2) NORTHERLY ALONG SAID WESTERLY LINE OF PARCEL 3 AND PARCEL 2 AND ALONG SAID CURVE THROUGH A CENTRAL ANGLE OF 00°31'15" AN ARC LENGTH OF 135.89 FEET (CHORD BEARS: NORTH 00°51'12" EAST, 135.89 FEET) TO THE SOUTHWEST CORNER OF PARCEL 1 AS SHOWN ON SAID PARCEL MAP; THENCE (3) NORTH 89°07'56" EAST ALONG THE SOUTHERLY LINE OF PARCEL 1 A DISTANCE OF 360.68 FEET TO THE SOUTHEAST CORNER OF PARCEL 1; THENCE (4) SOUTH 01°01'09" WEST ALONG THE EASTERLY LINE OF PARCEL 3 AND WESTERLY LINE OF PARCEL 2 A DISTANCE OF 120.99 FEET TO THE POINT OF BEGINNING.

PARCEL HEREIN IS PURSUANT TO A LOT LINE ADJUSTMENT APPROVED BY THE CITY OF GRIDLEY, SHOWN AS LOT A, IN CERTIFICATE OF COMPLIANCE RECORDED AUGUST 28, 2017 AS SERIAL NO. 2017-0029886 OF OFFICIAL RECORDS.

APN: 024-260-096-000

PROTOTYPE RENDERING



NOTE:
PERSPECTIVE IMAGE IS A DUTCH BROS PROTOTYPE RENDERING. IMAGE MAY NOT REFLECT ACTUAL ARCHITECTURAL ELEMENTS OF BUILDING AND/OR SITE.

VICINITY MAP

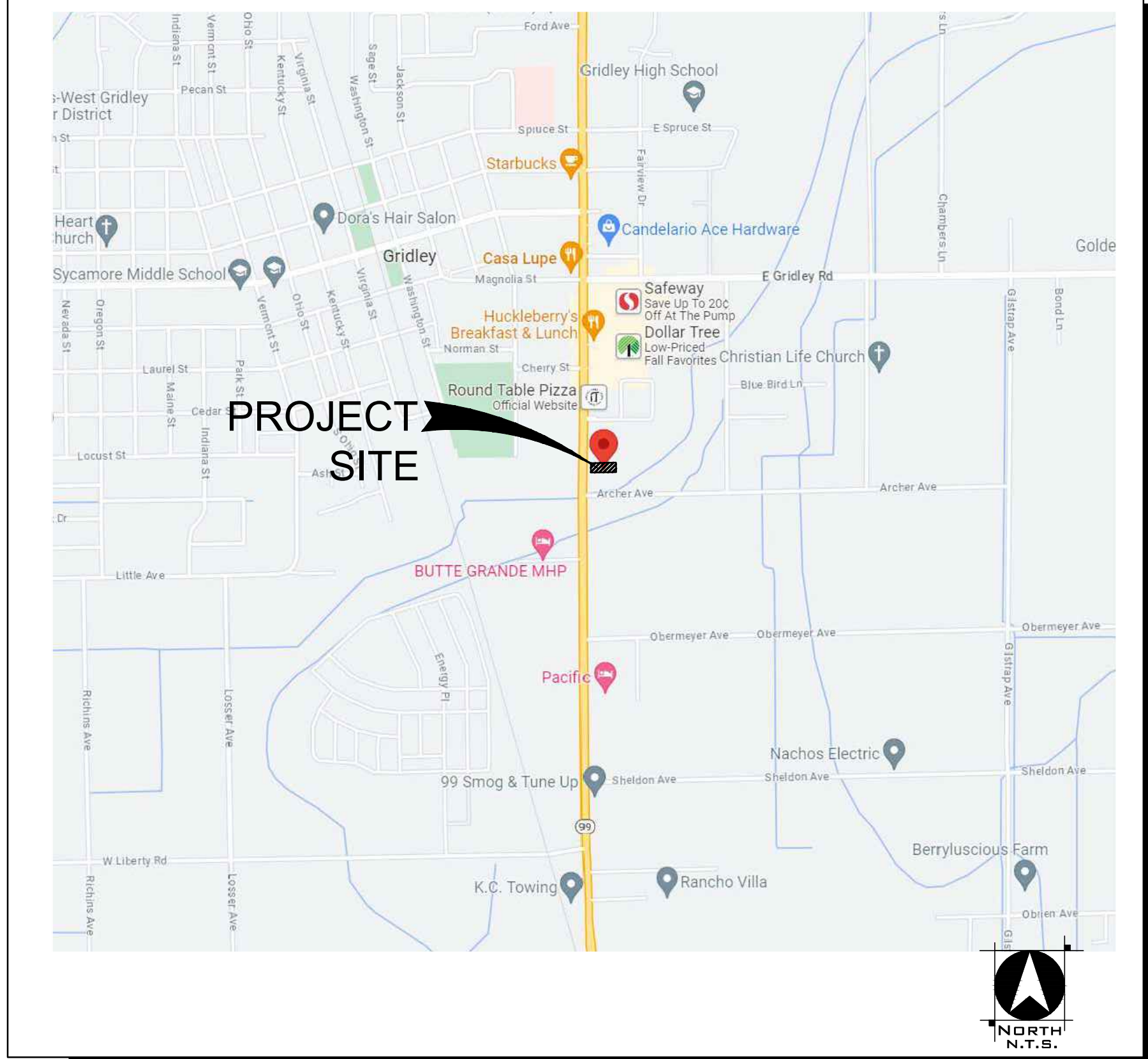

CONTEXT SITE PLAN

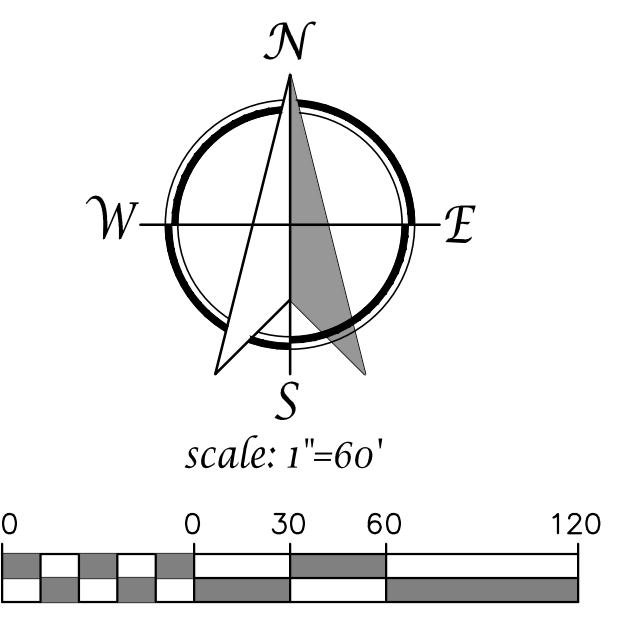
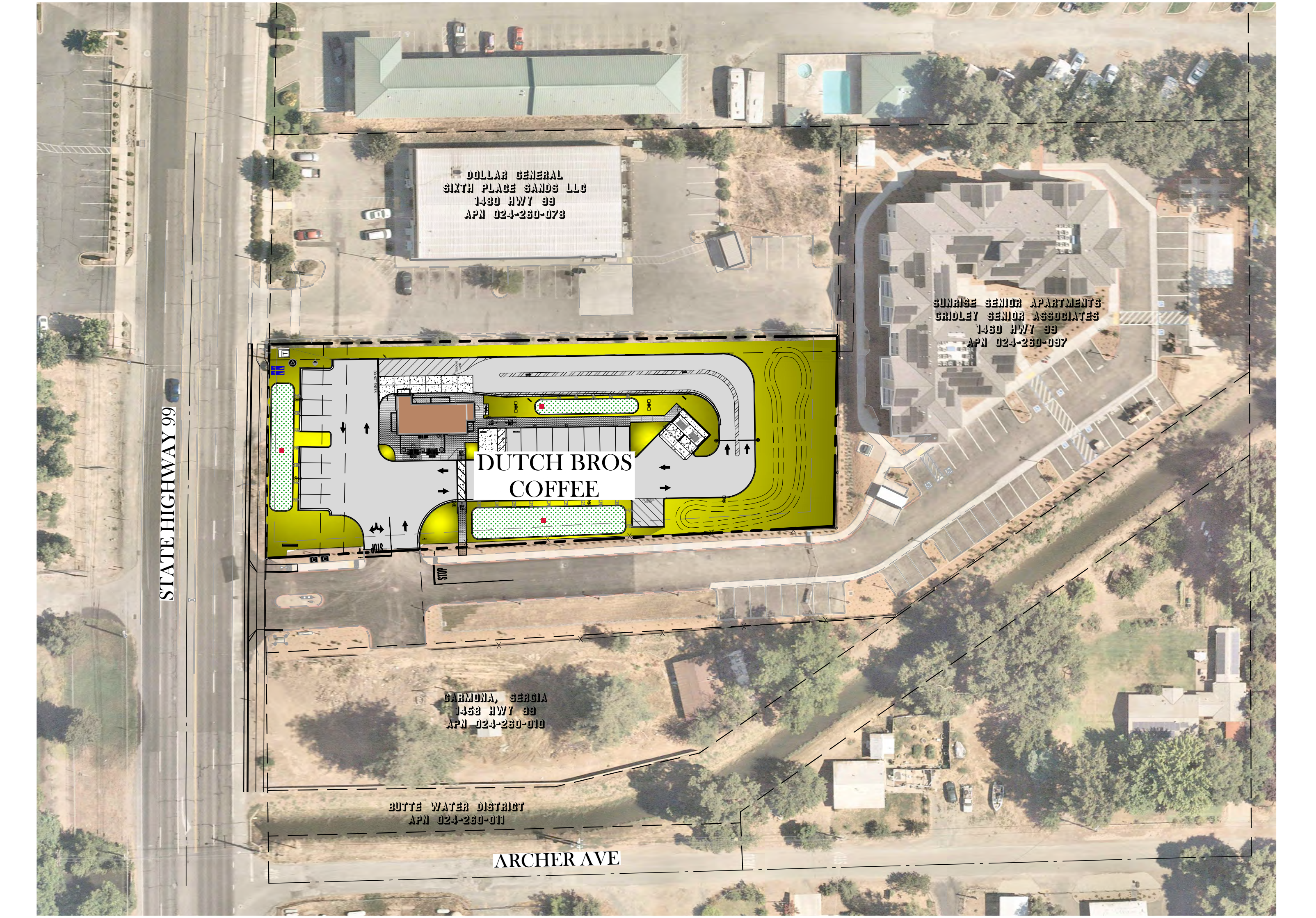

OWNER/APPLICANT/CONSULTANT CONTACT INFORMATION

OWNER
TAKHAR SARBIJIT S.
3861 WATERMIST WAY
SACRAMENTO, CA 95835

DEVELOPER/APPLICANT
COLE VALLEY PARTNERS
3519 NE 15TH AVE, SUITE 251
PORTLAND, OR 97212
ATTN: BRADEN BERNARDIS
braden.bernardis@cvpre.com

PLANNER/ENGINEER
TSD ENGINEERING, INC
785 ORCHARD DRIVE, SUITE 110
FOLSOM, CA 95630
ATTN: CHRIS SCHULZE
cschulze@tsdeng.com

ARCHITECT
ARMET DAVIS NEWLOVE & ASSOCIATES
1330 OLYMPIC BLVD
SANTA MONICA, CA 90404
ATTN: PAUL DEPPE
deppe@adnarch.com

LANDSCAPE ARCHITECT
YAMASAKI LANDSCAPE ARCHITECTURE
1223 HIGH STREET
AUBURN, CA 95603
ATTN: JEFF AMBROSIA
jeff@yamasaki-la.com

SIGNAGE
ESSA SIGN & AWNING CO.
89975 PRAIRE ROAD
EUGENE, OR 97402
ATTN: NICHOLAS JOHNSON
njohnson@essasigns.com

INDEX OF DRAWINGS

SHEET	TITLE
C-0	COVER SHEET
ALTA	ALTA SURVEY
C-1	PRELIMINARY SITE PLAN
C-2	PRELIMINARY SITE DETAILS
C-3	PRELIMINARY UTILITY PLAN
C-4	PRELIMINARY GRADING PLAN
C-5	PRELIMINARY GRADING SECTIONS
C-6	PRELIMINARY STORMWATER MGMT PLAN
L-1	PRELIMINARY LANDSCAPE PLAN
A6.1	BUILDING ELEVATIONS
E0.03	EXTERIOR LIGHTING CUTSHEETS
E0.04	EXTERIOR LIGHTING CUTSHEETS
E0.05	EXTERIOR LIGHTING CUTSHEETS

DUTCH BROS COFFEE - GRIDLEY CA COVER SHEET

State Hwy 99, Gridley, California

Proposed By: Cole Valley Partners
3519 NE 15th Street
Portland, OR 97212

C-0

TSD ENGINEERING, INC.
785 Orchard Drive, Suite #110
Folsom, CA 95630
Phone: (916) 608-0707
Fax: (916) 608-0701
JANUARY 26, 2024 - INITIAL SUBMITTAL

P:\Projects\499-005_02_DWG\3- Planning\FIG\C-0 Cover Sheet.dwg - Denise, 16:21:17, 01-30-24

SITE LEGEND:

	ASPHALT PAVEMENT
	BUILDING AREA
	LANDSCAPE AND EXISTING VEGETATION AREAS
	CONCRETE SIDEWALK/HARDSCAPE
	CONCRETE PAVEMENT
	BIORETENTION BASIN
	ACCESSIBLE PATH OF TRAVEL

OVERALL DEVELOPMENT SUMMARY:

SITE SUMMARY	DEVELOPMENT STANDARDS
ADDRESS: 1464 STATE HIGHWAY 99	ZONING: C-2
APN: 024-260-096	USE: COFFEE SHOP W/DRIVE THRU
ZONING: C-2	LOT AREA: NO MINIMUM
GENERAL PLAN: COMMERCIAL	SETBACK - YARD
AREA GROSS: ±1.06 AC	FRONT (HWY 99): 5 FEET
AREA NET: ±1.06 AC	SIDE (SOUTH R-DISTRICT): 10 FEET
	SIDE (NORTH C-2): 0 FEET
	REAR (R-DISTRICT): 15 FEET
	HEIGHT: 50 FEET
	LOT COVERAGE (BLDG&PARK): 90% MAX
BUILDING SUMMARY	
DUTCH BROS COFFEE FLOOR AREA: 950 SQFT	
DUTCH BROS COFFEE COVERED AREA: 1515 SQFT	
1-STORY & HEIGHT: 24 FEET	
PARKING SUMMARY	
TOTAL: 17 SPACES	

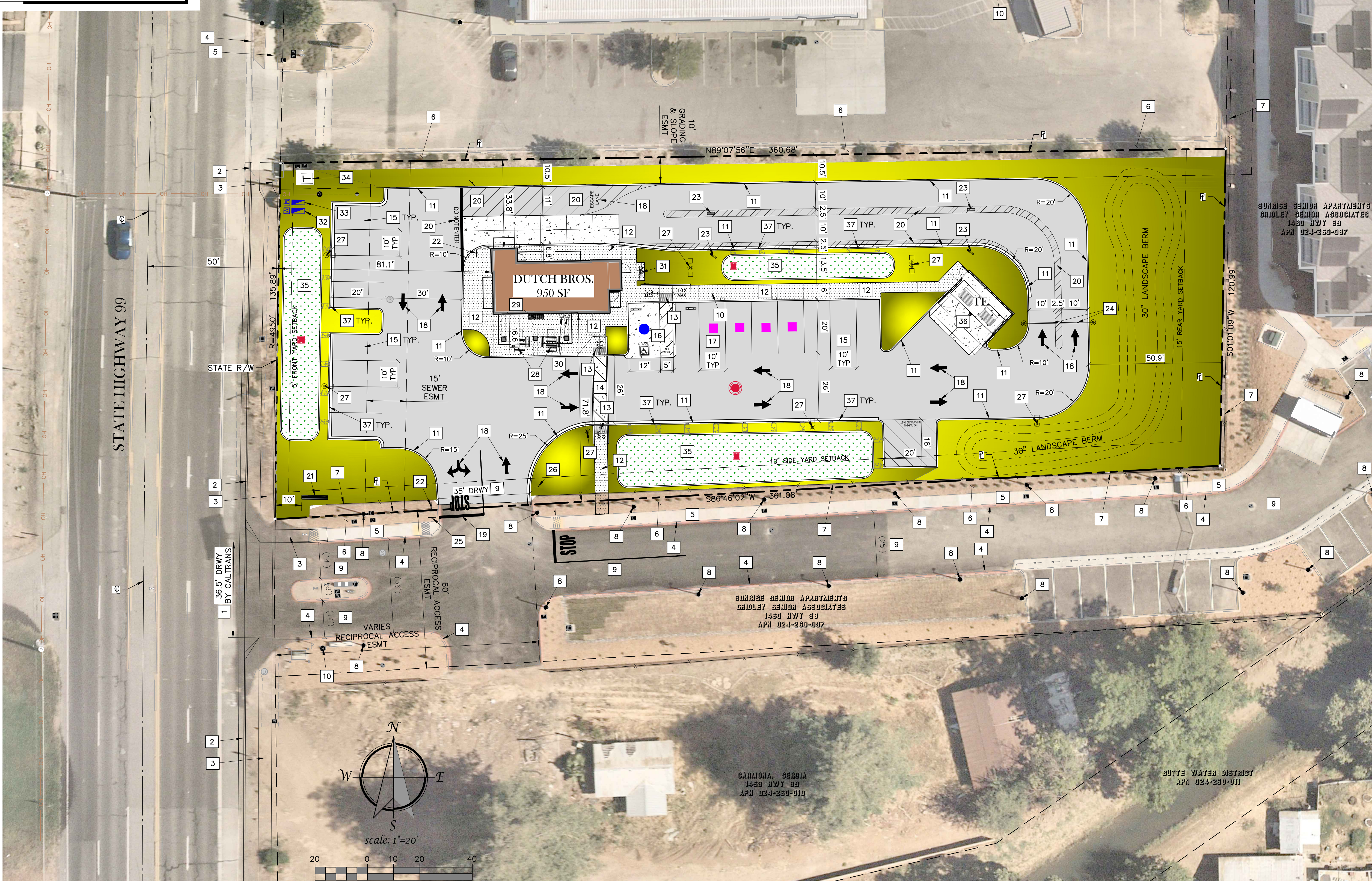

PROJECT PARKING SUMMARY:

PARKING REQUIRED (17.76.030)

VEHICLE PARKING:
 COMMERCIAL USE (RESTAURANT = 1 SPACE PER 3 SEAT OR 3 OCCUPANTS
 NO. OCCUPANT (PER UBC) = 12

TOTAL VEHICLE PARKING REQUIRED - 12/3 = 4 SPACES

BIKE PARKING:
 2022 CALGREEN NON RESIDENTIAL = 5% VEHICLE SPACES PROVIDED
 (MIN OF 2 BIKE CAPACITY)

TOTAL BIKE PARKING REQUIRED - 1 RACK/2 SPACES

TOTAL PROVIDED VEHICLE PARKING - SUMMARY

TOTAL PARKING PROVIDED - 17 SPACES

SUBTOTAL EV PARKING - CBC CALGREEN - NONRESIDENTIAL MANDATORY

ELECTRIC VEHICLE CHARGING 5.106.5.3
 EV CAPABLE (EVC) PER TABLE 5.106.5.3.1 1
 EV CHARGER (EVC) PER TABLE 5.106.5.3.1 0

SUBTOTAL ACCESSIBLE PROVIDED PARKING - CBC 11B

PARKING STALL (PER 11B-208.2, TABLE 11B-208.2)

	STD AISLE	VAN AISLE	SUBTOTAL
	0	1	1

PROVIDED - PARKING SCHEDULE & SUMMARY

PARKING FACILITY	PARKING SPACE TYPE						TOTAL
	ACCESSIBLE STD	ACCESSIBLE VAN	EV CHARGING	EV CHARGING	VEHICLE	RV	
SURFACE	0	1	4	0	0	0	17
	1		4		12		TOTAL 17

PROVIDED - BICYCLE PARKING

EXTERIOR SPACES - 2

- SITE DEVELOPMENT NOTES:**
- | | |
|--|---|
| 1 CALTRANS DRIVEWAY - BY CALTRANS | 24 (P) CLEARANCE ARM |
| 2 CALTRANS CURB & GUTTER - BY CALTRANS | 25 (P) STOP SIGN |
| 3 CALTRANS SIDEWALK - BY CALTRANS | 26 (P) UNAUTHORIZED PARKING SIGN(S) |
| 4 (E) CURB | 27 (P) PARKING LOT LIGHT |
| 5 (E) SIDEWALK | 28 (P) TABLE & CHAIRS (C/C2) |
| 6 (E) LANDSCAPE | 29 (P) BENCH (A/C2) |
| 7 (E) FENCE | 30 (P) TRASH RECEPTACLE (B/C2) |
| 8 (E) LIGHT POLE | 31 (P) BIKE RACK (2 BIKE SPACES) (D/C2) |
| 9 (E) PRIVATE DRIVE | 32 (P) DOMESTIC WATER METER & BKFLW |
| 10 (E) FIRE HYDRANT | 33 (P) IRRIGATION METER & BKFLW |
| 11 (P) CONCRETE CURB | 34 (P) TRANSFORMER |
| 12 (P) CONCRETE SIDEWALK/HARDSCAPE | 35 (P) BIORETENTION BASIN |
| 13 (P) CONCRETE ACCESSIBLE CURB RAMP | 36 (P) TRASH ENCLOSURE (11'-4"x24') |
| 14 (P) CONCRETE ACCESSIBLE CROSSWALK | 37 (P) CURB CUT |
| 15 10'x20' PARKING SPACE | |
| 16 12'x20' VAN ACCESSIBLE PARKING SPACE W/5' AISLE | |
| 17 10'x20' EV CAPABLE PARKING SPACE | |
| 18 (P) PAVEMENT MARKING LEGEND | |
| 19 (P) PAVEMENT MARKING STOP BAR | |
| 20 (P) PAVEMENT MARKING STRIPING | |
| 21 (P) MONUMENT SIGN | |
| 22 (P) SITE DIRECTORY SIGN | |
| 23 (P) MENU BOARD | |

DUTCH BROS COFFEE - GRIDLEY CA PRELIMINARY SITE PLAN

State Hwy 99, Gridley, California

Proposed By: Cole Valley Partners
 3519 NE 15th Street
 Portland, OR 97212

TSD ENGINEERING, INC.
 785 Orchard Drive, Suite #110
 Folsom, CA 95630
 Phone: (916) 608-0707
 Fax: (916) 608-0701
C-1
 JANUARY 26, 2024 - INITIAL SUBMITTAL

P:\Projects\499-005\02 DWG\3- Planning\FIG\C-1 Preliminary Site Plan.dwg - Demiso, 16:44:11, 01-30-24



A
BENCH
NOT TO SCALE

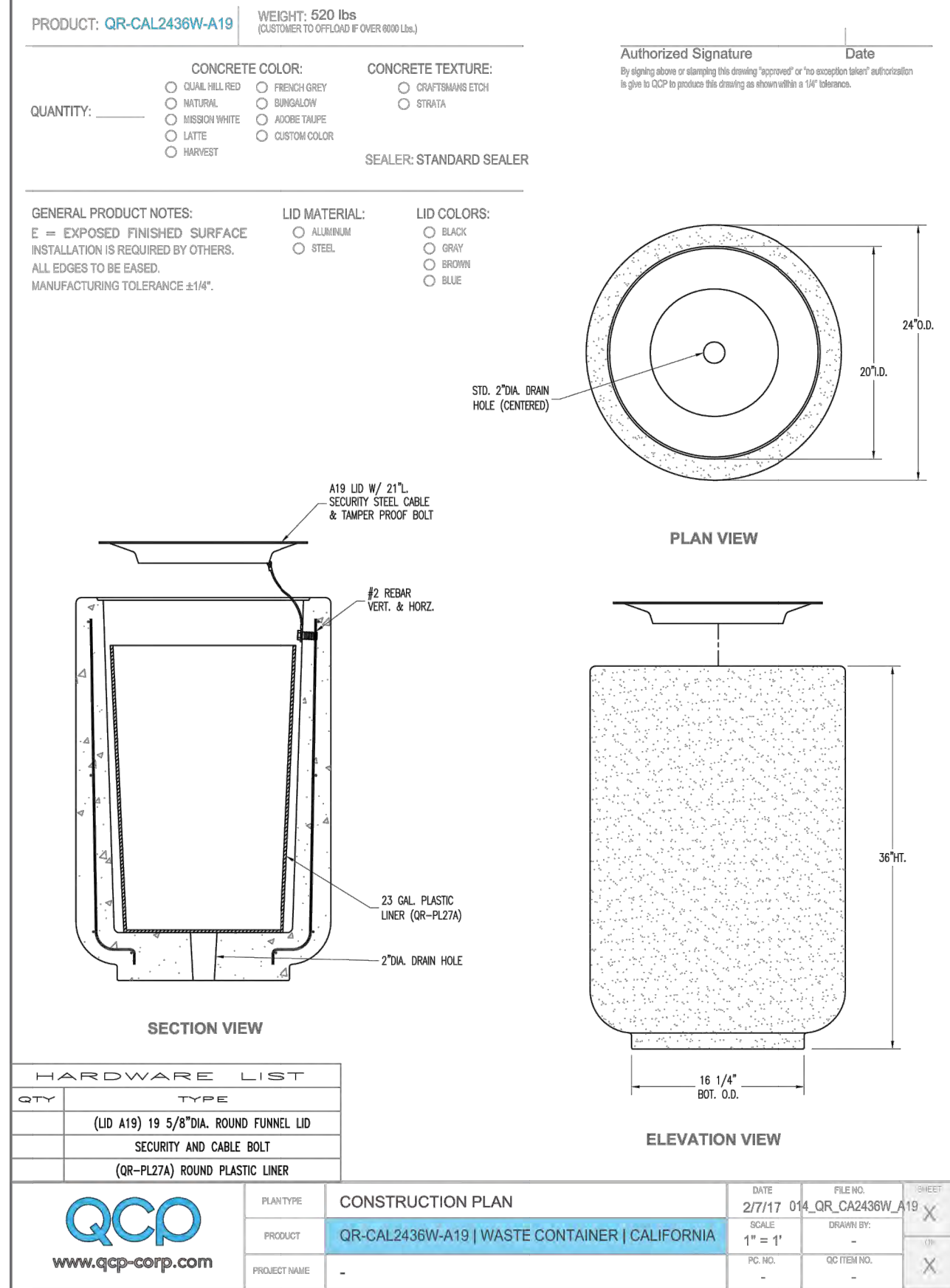

B
TRASH RECEPTACLE
NOT TO SCALE



C
CHAIR & TABLE - COMMERCIAL GRADE
NOT TO SCALE

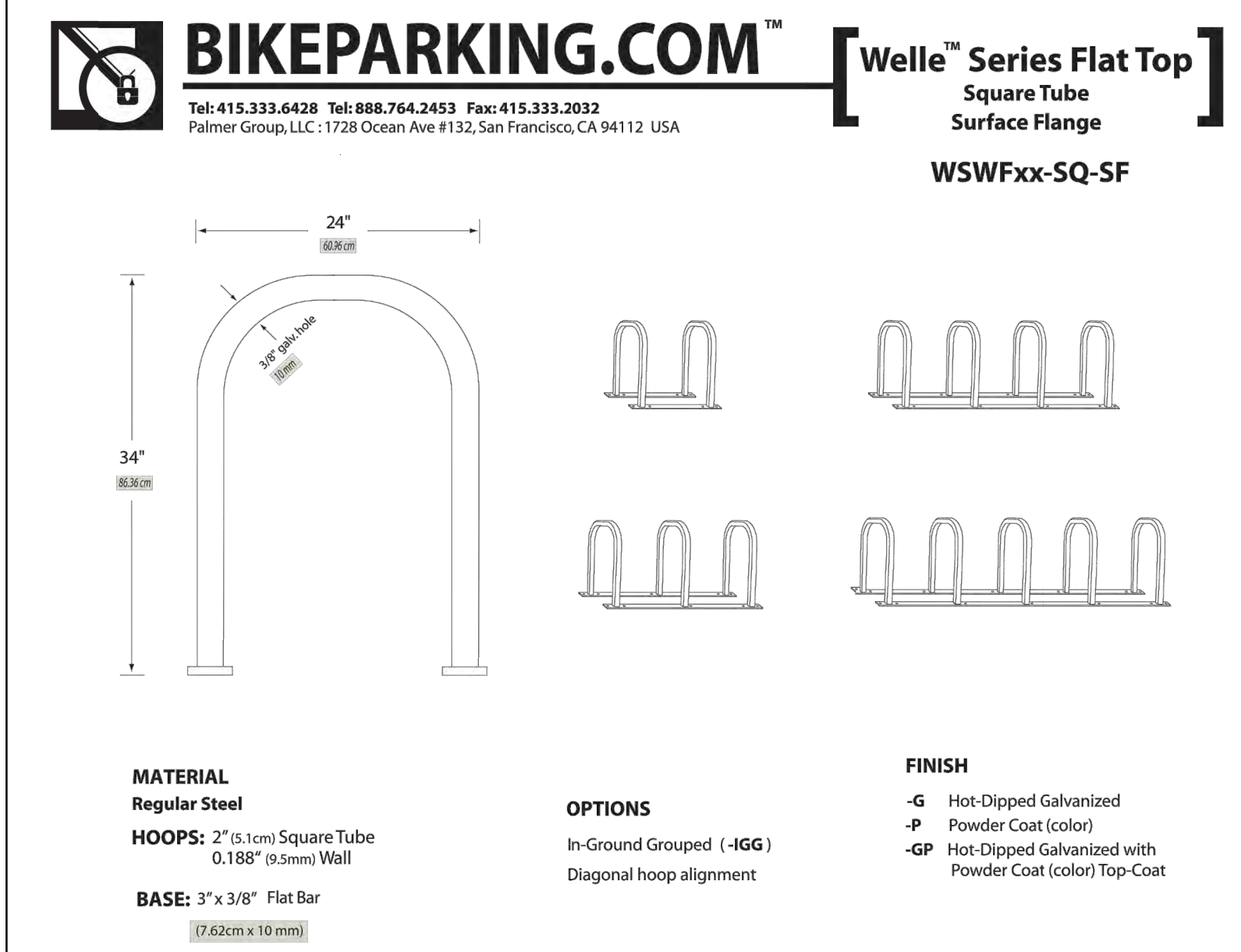

WELLE™ SERIES FLAT TOP RACK SQUARE TUBE SURFACE FLANGE

Model	Hoops	Bikes	Length			Mounting Holes	Front View
			24" Centers	28" Centers	30" Centers		
WSWF04-SQ-SF	2	4	30"	34"	36"	8	
WSWF06-SQ-SF	3	6	54"	62"	66"	10	
WSWF08-SQ-SF	4	8	78"	90"	96"	12	
WSWF10-SQ-SF	5	10	102"	118"	126"	14	

© 2005 Palmer Group, LLC - All Rights Reserved.

D
BIKE RACK
NOT TO SCALE

DUTCH BROS COFFEE - GRIDLEY CA PRELIMINARY SITE DETAILS

State Hwy 99, Gridley, California

Proposed By: Cole Valley Partners
 3519 NE 15th Street
 Portland, OR 97212

C-2

TSD ENGINEERING, INC.
 785 Orchard Drive, Suite #110
 Folsom, CA 95630
 Phone: (916) 608-0707
 Fax: (916) 608-0701
 JANUARY 26, 2024 - INITIAL SUBMITTAL

P:\Projects\499-005\02 DWG\3- Planning\FIG\C-2 Preliminary Site Details.dwg, Deniso, 16:19:25, 01-30-24

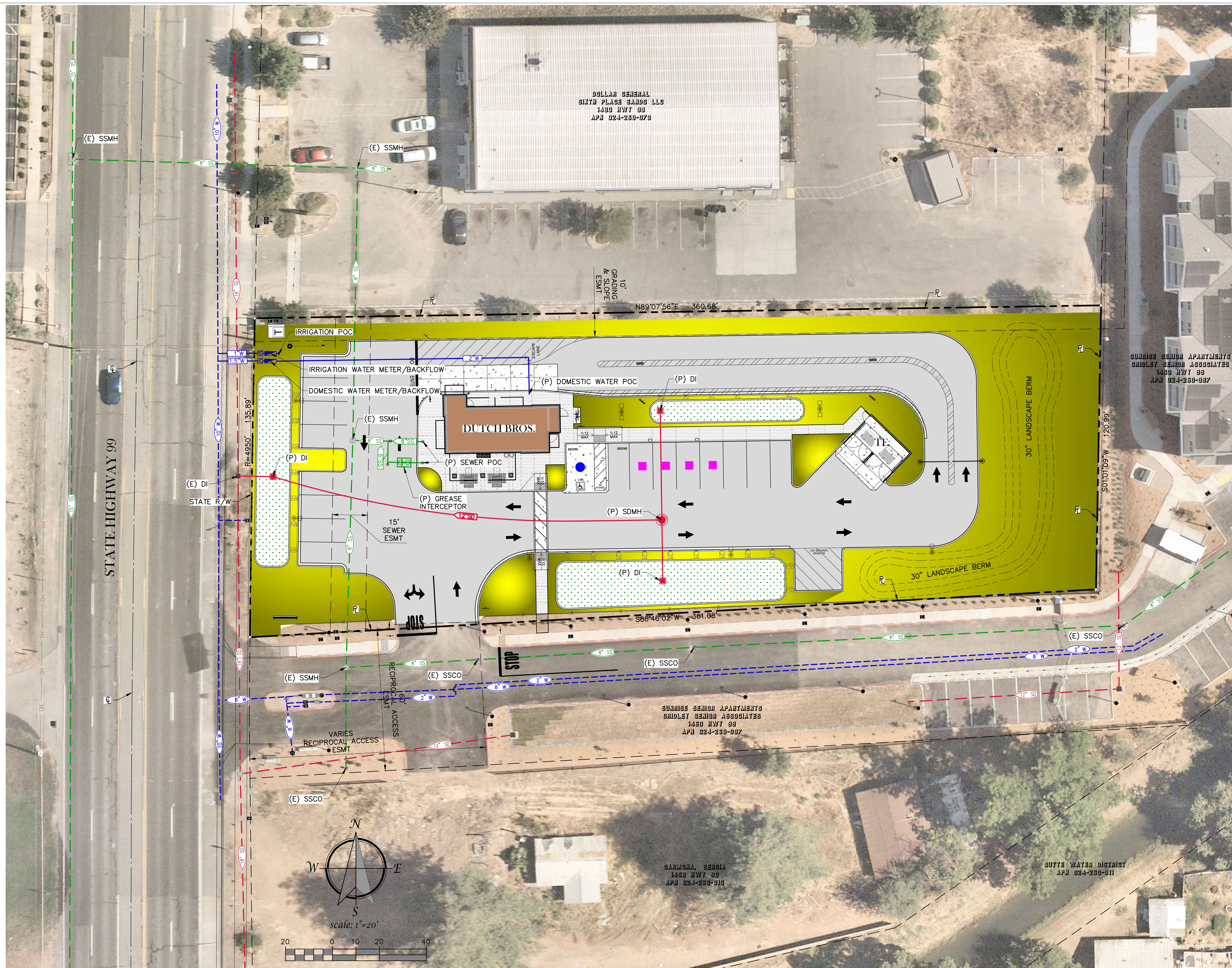

LEGEND		
DESCRIPTION	PROPOSED	EXISTING
STORM DRAIN		
STORM DRAIN MANHOLE		
STORM DRAIN DRAIN INLET		
DOMESTIC WATER (PRIVATE)		
IRRIGATION WATER (PRIVATE)		
FIRE SERVICE (PRIVATE)		
FIRE WATER (PRIVATE)		
FIRE HYDRANT		
METER & BACKFLOW (RP)		
SEWER (PUBLIC OR PRIVATE AS SHOWN)		
SEWER MANHOLE		

DUTCH BROS COFFEE - GRIDLEY CA PRELIMINARY UTILITY PLAN

State Hwy 99, Gridley, California

Proposed By: Cole Valley Partners
 3519 NE 15th Street
 Portland, OR 97212

C-3

TSD ENGINEERING, INC.
 785 Orchard Drive, Suite #110
 Folsom, CA 95630
 Phone: (916) 608-0707
 Fax: (916) 608-0701
 JANUARY 26, 2024 - INITIAL SUBMITTAL

P:\Projects\499-005_02_DWG\3- Planning\FIG\C-3 Preliminary Utility Plan.dwg, Deniso, 16:21:35, 01-30-24

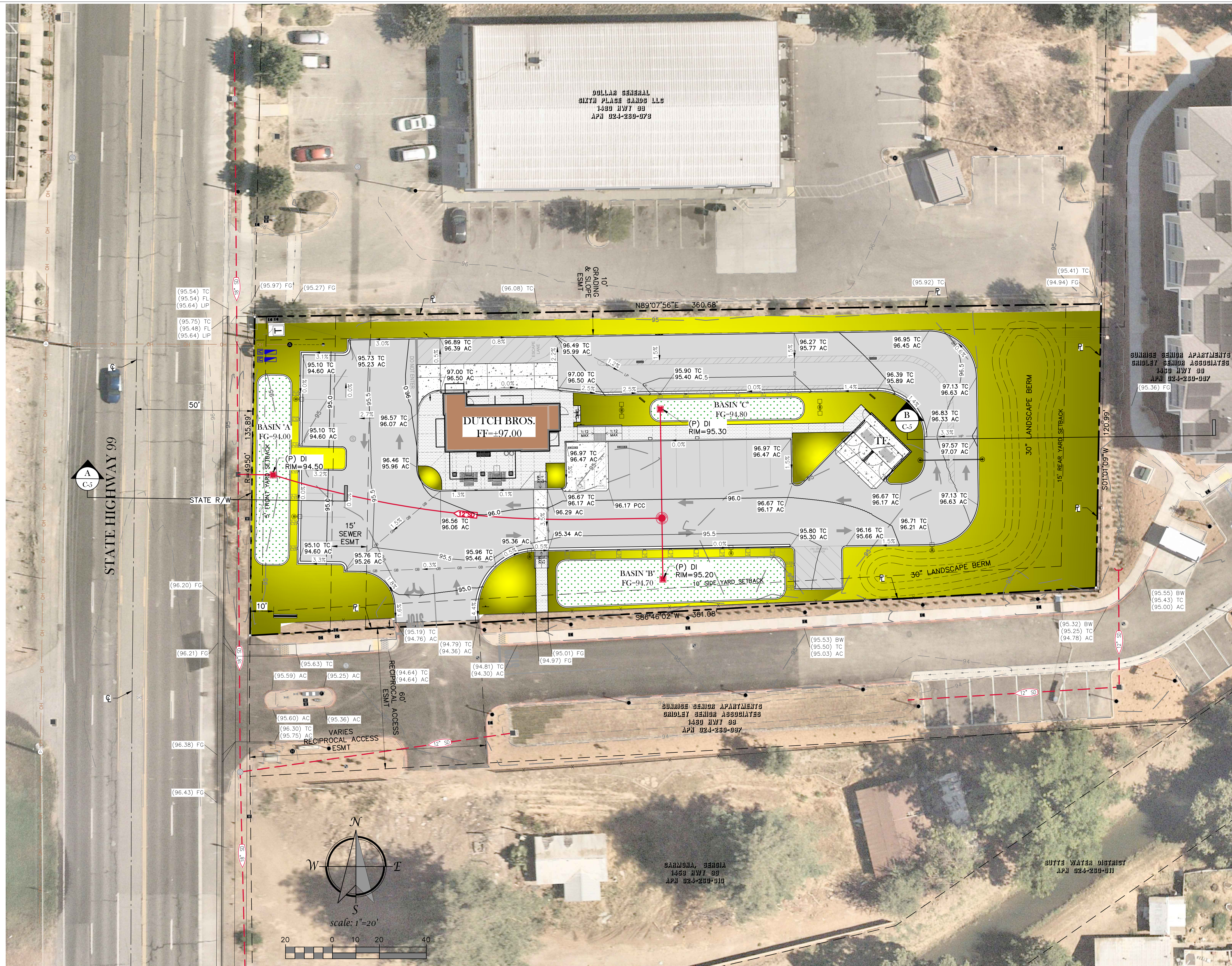

LEGEND		
DESCRIPTION	PROPOSED	EXISTING
DESIGN ELEVATION	130.0 FG	(98.0) FF
CONTOUR	— 130 —	- - 130 - -
STORM DRAIN	— 12" 50 —	- - 12" 50 - -
MANHOLE	●	○
DROP INLET	■	▣
GRADE BREAK	≡≡≡	≡≡≡

DUTCH BROS COFFEE - GRIDLEY CA PRELIMINARY GRADING PLAN

State Hwy 99, Gridley, California

Proposed By: COLE VALLEY PARTNERS Real Estate

Cole Valley Partners
3519 NE 15th Street
Portland, OR 97212

C-4

TSD ENGINEERING, INC. EXPERIENCE
785 Orchard Drive, Suite #110
Folsom, CA 95630
Phone: (916) 608-0707
Fax: (916) 608-0701

JANUARY 26, 2024 - INITIAL SUBMITTAL

P:\Projects\499-005_02_DWG\3- Planning\FIG\C-4 Preliminary Grading Plan.dwg, Denisa, 16:35:10, 01-30-24

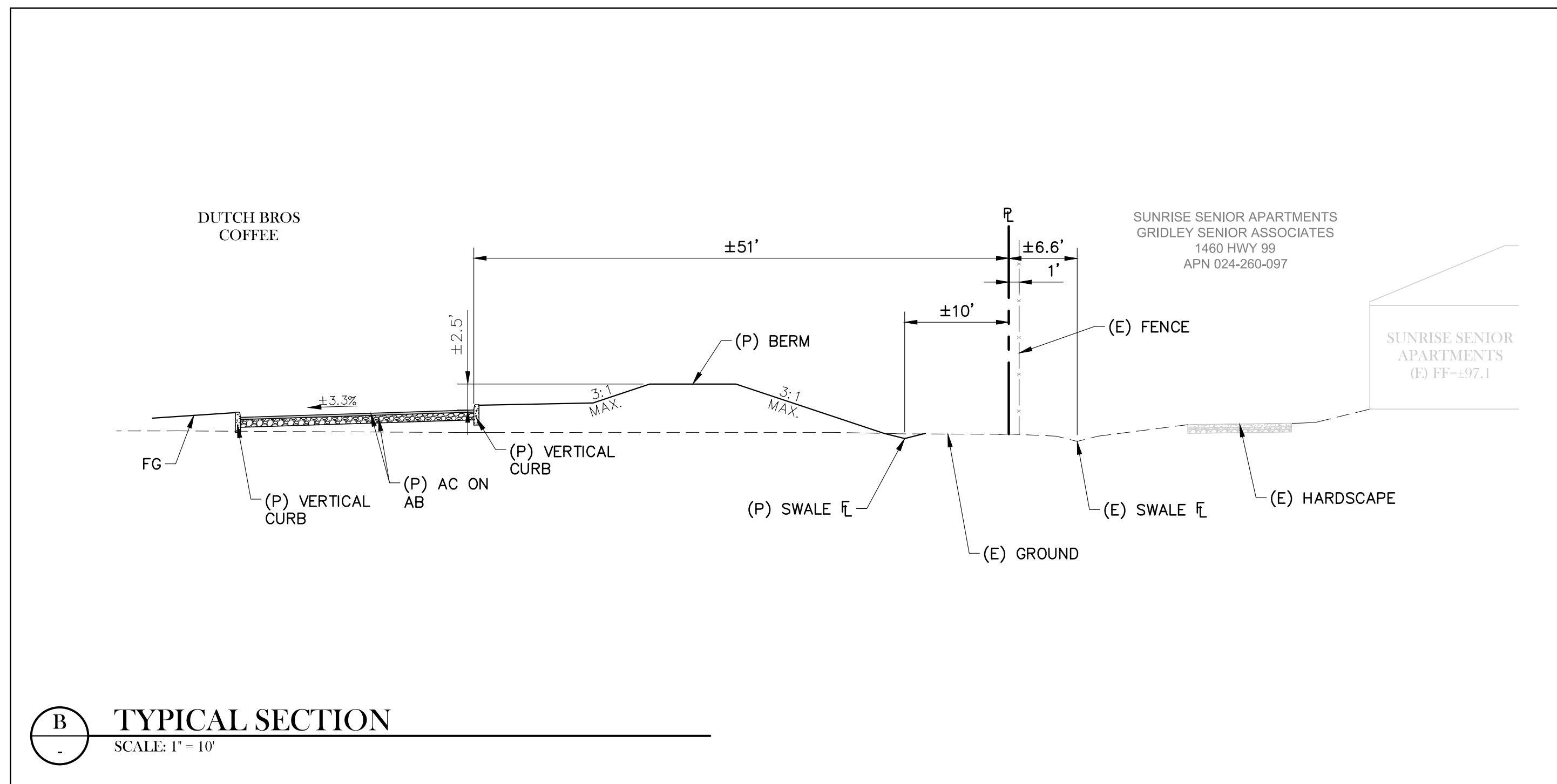
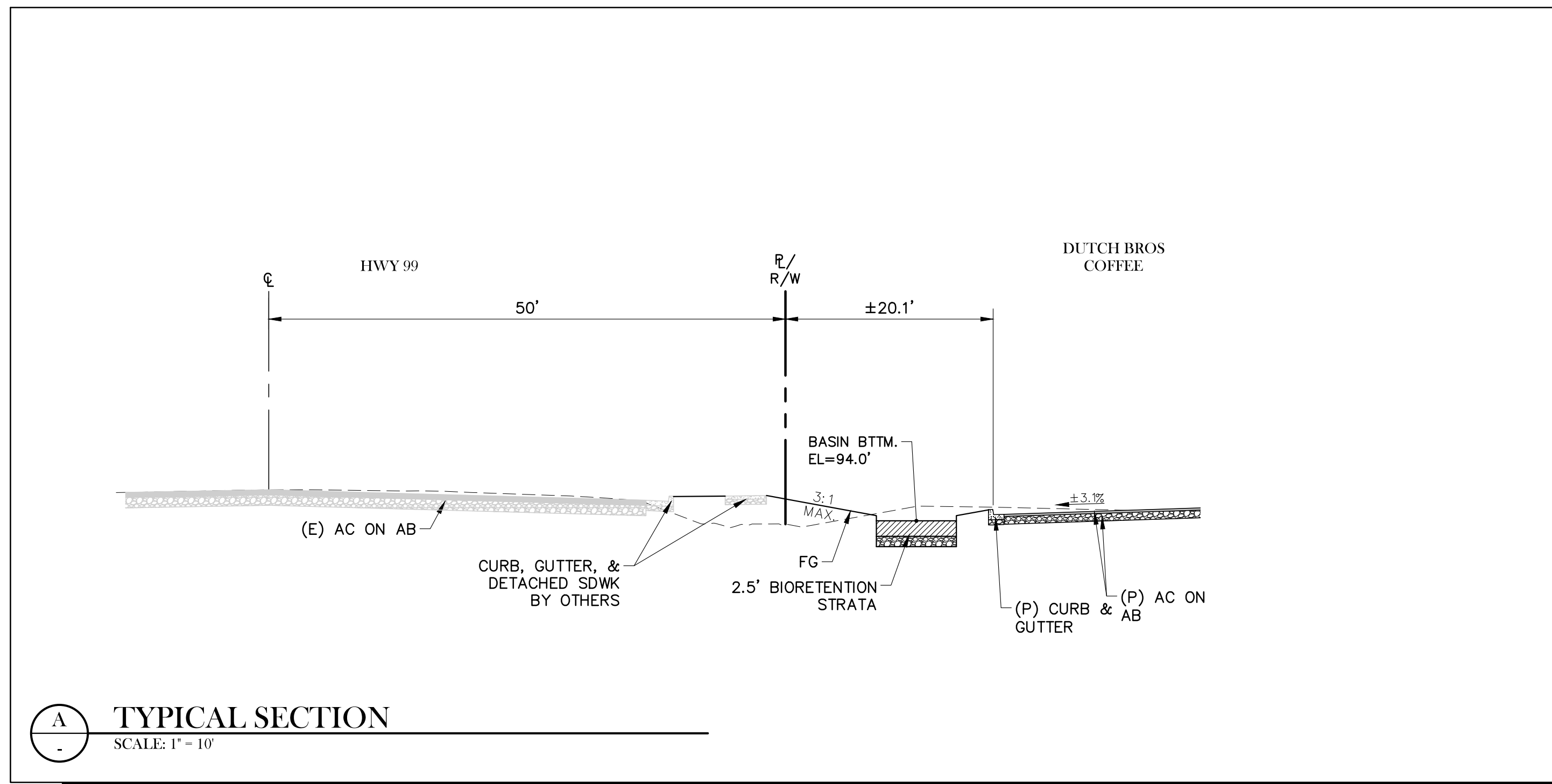

DUTCH BROS COFFEE - GRIDLEY CA PRELIMINARY GRADING SECTIONS

State Hwy 99, Gridley, California

Proposed
By:



Cole Valley Partners
 3519 NE 15th Street
 Portland, OR 97212

C-5

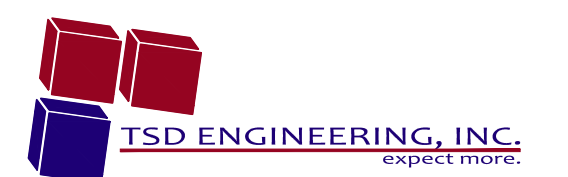

785 Orchard Drive, Suite #110
 Folsom, CA 95630
 Phone: (916) 608-0707
 Fax: (916) 608-0701

JANUARY 26, 2024 - INITIAL SUBMITTAL

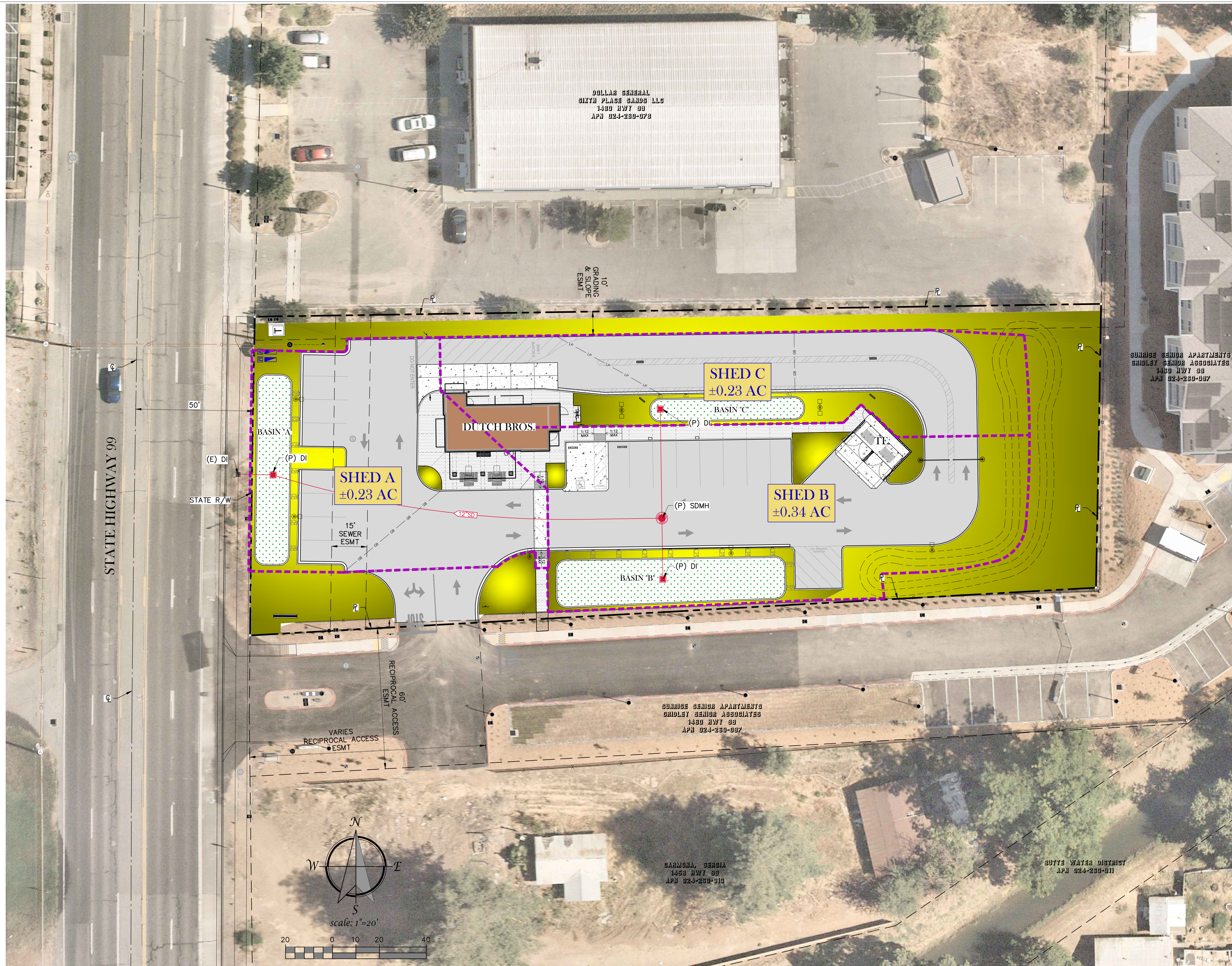

LEGEND	
PROPOSED	DESCRIPTION
	STORM DRAIN
	EXIST. STORM DRAIN
	SHED BOUNDARY
	"SHED ID" SHED SIZE

Project Variables -- California Phase II LID Sizing Tool - v1.2
 Climate Station: CHICO UNIV FARM
 Saturated Hydraulic Conductivity: 1 in/hr
 Design Storm: 0.80 inches

Shed	Total Area	Impervious Area	LID BMP Type	Pre-project Runoff Volume		BMP Area Required	
				ac-ft/yr	ac	sf	
Shed A	0.23	0.21	Bioretention - 18" Soil - 12" Gravel	0.39	0.008	348	
Shed B	0.34	0.26	Bioretention - 18" Soil - 12" Gravel	0.48	0.010	436	
Shed C	0.23	0.18	Bioretention - 18" Soil - 12" Gravel	0.33	0.007	305	

DUTCH BROS COFFEE - GRIDLEY CA PRELIMINARY STORMWATER MGMT PLAN

State Hwy 99, Gridley, California

Proposed By: COLE VALLEY PARTNERS Real Estate

Cole Valley Partners
 3519 NE 15th Street
 Portland, OR 97212

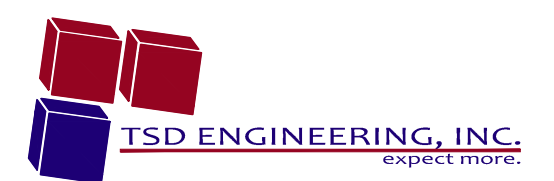

785 Orchard Drive, Suite #110
 Folsom, CA 95630
 Phone: (916) 608-0707
 Fax: (916) 608-0701

C-6

JANUARY 26, 2024 - INITIAL SUBMITTAL

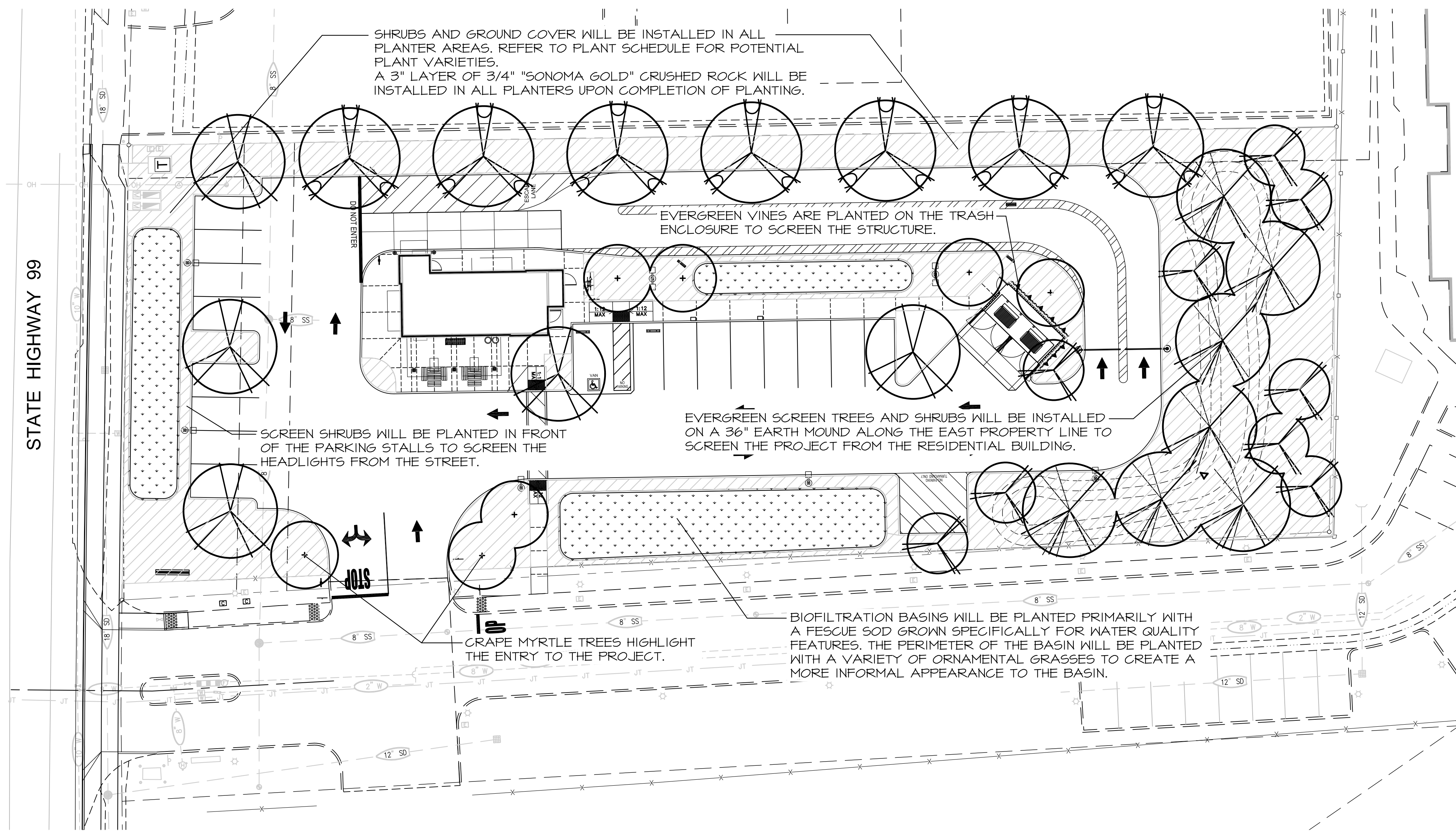

PLANT SCHEDULE

SYMBOL	CODE	BOTANICAL / COMMON NAME	SIZE	WATER USE	SPACING
TREES					
	CED DEO	Cedrus deodara / Deodar Cedar	15 gal	LOW	
	CER FOR	Cercis canadensis 'Forest Pansy' / Forest Pansy Redbud	15 gal	MED	
	LAG NAT	Lagerstroemia x 'Natchez' / Crape Myrtle	15 gal	LOW	
	PIS KEI	Pistacia chinensis 'Keith Davey' / Keith Davey Chinese Pistache	15 gal	LOW	
	PLA COL	Platanus x acerifolia 'Columbia' / Columbia London Plane Tree	15 gal	MED	
POTENTIAL SHRUBS					
	ARC SUN	Arctostaphylos x 'Sunset' / Sunset Manzanita	5 gal	LOW	
	BER ATR	Berberis thunbergii 'Atropurpurea' / Red Leaf Japanese Barberry	5 gal	LOW	
	CAL LJN	Callistemon viminalis 'Little John' / Little John Weeping Bottlebrush	5 gal	LOW	
	CIS HMI	Cistus x hybridus 'Mickie' / Mickie Rockrose	5 gal	LOW	
	MAH SOF	Mahonia eurybracteata 'Soft Caress' / Mahonia Soft Caress	5 gal	LOW	
	NAN HAR	Nandina domestica 'Harbour Dwarf' / Harbour Dwarf Heavenly Bamboo	5 gal	LOW	
	RHA EVE	Rhamnus californica 'Eve Case' / California Coffeeberry	5 gal	LOW	
	RHA MIN	Rhaphiolepis umbellata 'Minor' / Dwarf Yedda Hawthorn	5 gal	LOW	
POTENTIAL GRASSES					
	CAL KAR	Calamagrostis x acutiflora 'Karl Foerster' / Feather Reed Grass	1 gal	LOW	
	LOM LON	Lomandra longifolia 'Platinum Beauty' / Mat Rush	1 gal	LOW	
	MUH REG	Muhlenbergia capillaris 'Regal Mist' / Regal Mist Pink Muhly Grass	1 gal	LOW	
	MUH RIG	Muhlenbergia rigens / Deer Grass	1 gal	LOW	
VINES					
	FIC PUM	Ficus pumila / Creeping Fig	5 gal	MED	
POTENTIAL GROUND COVERS					
	COT LOW	Cotoneaster dammeri 'Lowfast' / Lowfast Bearberry Cotoneaster	1 gal	LOW	48" o.c.
	LAN PUR	Lantana montevidensis / Purple Trailing Lantana	1 gal	LOW	36" o.c.
	TUR BIO	Turf Sod Biofiltration Sod / Drought Tolerant Grass Blend	sod	MED	

PLANTING STATEMENT

The proposed landscape plant palette consists of low water use shrubs, groundcover, trees, and ornamental grasses that are considered low maintenance and hardy. Choice of plants is guided by considerations of solar exposure and climate conditions of the site. Plant selection aims for longevity by selecting plants that are long lived varieties of trees, shrubs, groundcover, and grasses.

Shrubs and groundcover are minimum #1 size. Trees are minimum #15 size. Plant materials shall be spaced to provide substantial cover, but also to allow adequate room to mature into their natural form and ultimate size without required pruning.

IRRIGATION STATEMENT

The irrigation system will be serviced by a new point of connection. The irrigation design will consist of low volume inline drip irrigation. Proposed trees shall utilize bubbler irrigation to encourage deep root watering. The overall irrigation system will be designed with a smart irrigation controller. A weather sensor will be used to automatically adjust duration of application in accordance with recent weather conditions based on evapotranspiration. Maximum water allowance will be determined by State code. To also be consistent with the planting design, the irrigation design will create separate irrigation stations by hydrozone, locating plants of different water and solar needs into groups.

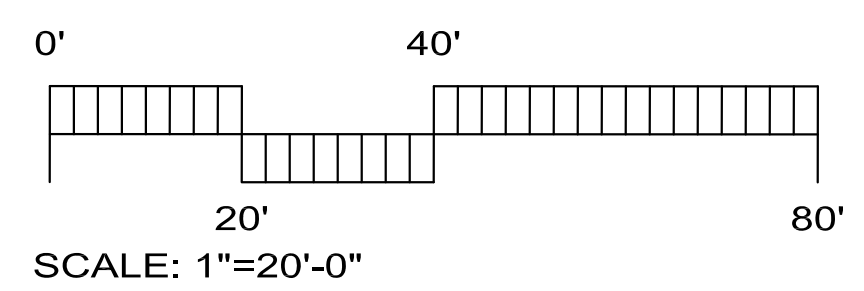

DUTCH BROS COFFEE - GRIDLEY CA PRELIMINARY LANDSCAPE PLAN

State Hwy 99, Gridley, California

Proposed By:  **Cole Valley Partners**
3519 NE 15th Street
Portland, OR 97212

L-1
JANUARY 19, 2024 - DRAFT-COORDINATION



S:\dwg\Dutch Bros - Gridley\DWG's\DOB\UBC PL.dwg - Jeff, 10:30:03, 01-19-24

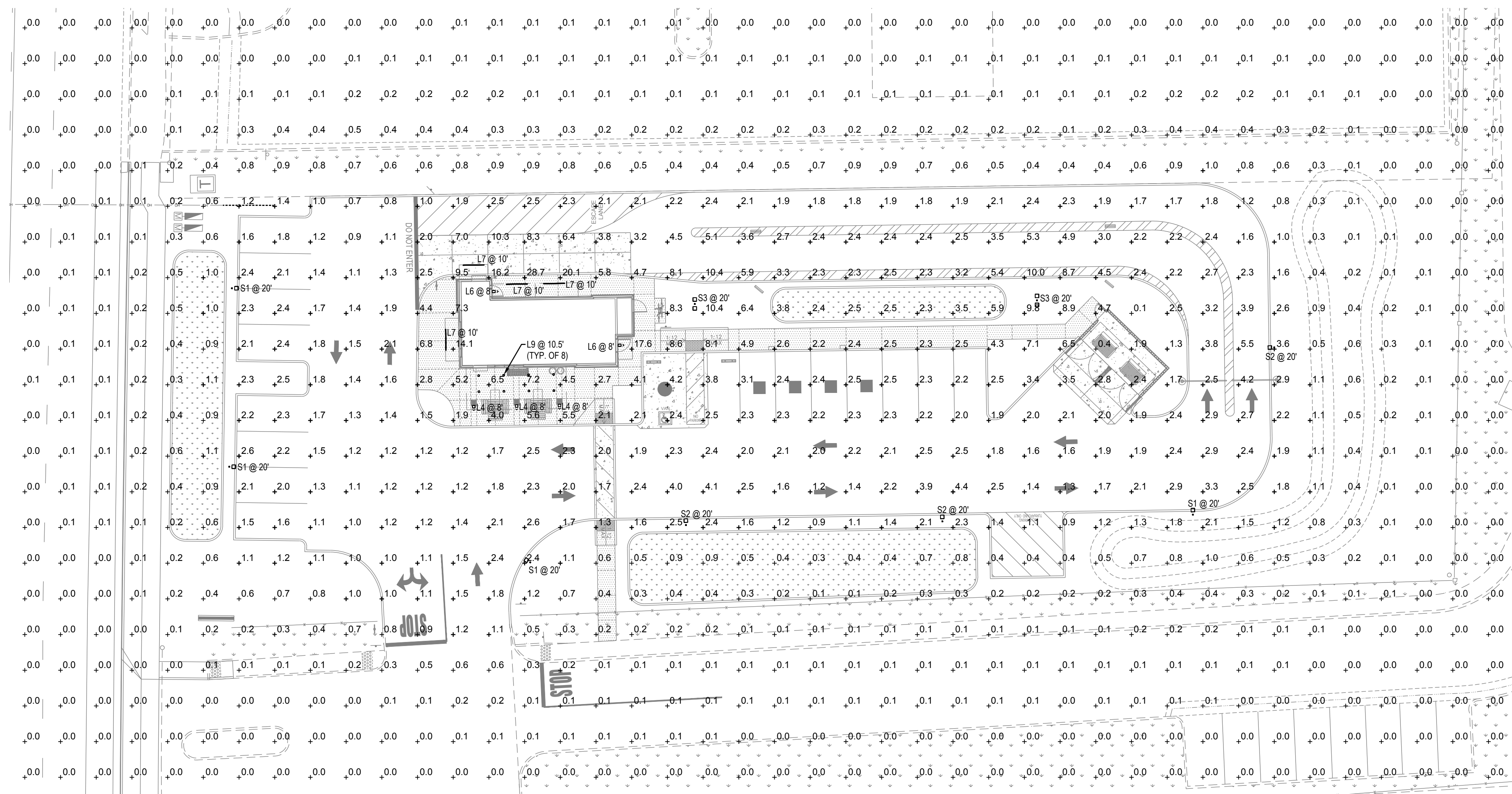

1 ELECTRICAL PHOTOMETRIC PLAN
SCALE: 1" = 20'-0"
NORTH

DESCRIPTION	SYMBOL	AVE	MAX	MIN	MAX/MIN	AVE/MIN
DRIVE THRU	+	3.2 fc	10.4 fc	1.0 fc	10.4:1	3.2:1
DRIVEWAY	+	1.9 fc	4.4 fc	0.4 fc	11.0:1	4.8:1
GENERAL HARDSCAPE	+	2.1 fc	28.7 fc	0.0 fc	N/A	N/A
PARKING - CENTER	+	2.6 fc	4.2 fc	2.2 fc	1.9:1	1.2:1
PARKING - EAST	+	2.1 fc	2.6 fc	1.2 fc	2.2:1	1.8:1
TRASH ENCLOSURE	+	1.6 fc	2.4 fc	0.4 fc	6.0:1	4.0:1

SYMBOL	LABEL	QTY	MANUFACTURER	CATALOG NUMBER	DESCRIPTION	NUMBER OF LAMPS	LUMENS PER LAMP	LIGHT LOSS FACTOR	WATTAGE
⊕	L4	3	LIGMAN	UMT-31416-14W-N-N-W30 (UNDER CANOPY)	MATRIX 3 SQUARE WALL DOWNLIGHT	1	1087	0.72	28.6
⊕	L6	2	RAB LIGHTING INC.	WPLED26Y-WPLED26Y/D10 (WALLPACK) - ALED26Y-ALED26Y/D10 (AREA LIGHTER) (UNDER CANOPY)	CAST FINNED METAL HOUSING, MOLDED PLASTIC REFLECTOR WITH SEMI-SPECULAR FINISH	1	3295	0.72	29.7
—	L7	4	SELF	CROWN-144-27TV-830_BA110 (UNDER CANOPY)	LED BATTEN STRIP, 3000K, UNDER CANOPY	1	6300	0.72	60
○	L9	8	DMF LIGHTING	DRD55-4R-07930 (UNDER CANOPY)	SURFACE MOUNT LED DOWNLIGHT, 3000K, UNDER CANOPY	1	757	0.72	8.37
□	S1	4	NLS LIGHTING, LLC	NV-1-T4-16L-1-30K-UNV (BUG RATING: B1 - U0 - G1)	NV SERIES AREA LIGHTING FIXTURE, TYPE IV DISTRIBUTION	1	6229	0.92	55
□	S2	3	NLS LIGHTING, LLC	NV-1-T3-16L-1-30K-UNV (BUG RATING: B1 - U0 - G1)	NV SERIES AREA LIGHTING FIXTURE, TYPE 3 DISTRIBUTION	1	6383	0.92	56
□	S3	2	NLS LIGHTING, LLC	NV-1-T3-32L-1-30K-UNV (BUG RATING: B2 - U0 - G2)	NV SERIES AREA LIGHTING FIXTURE, TYPE 3 DISTRIBUTION	2	12081	0.92	212

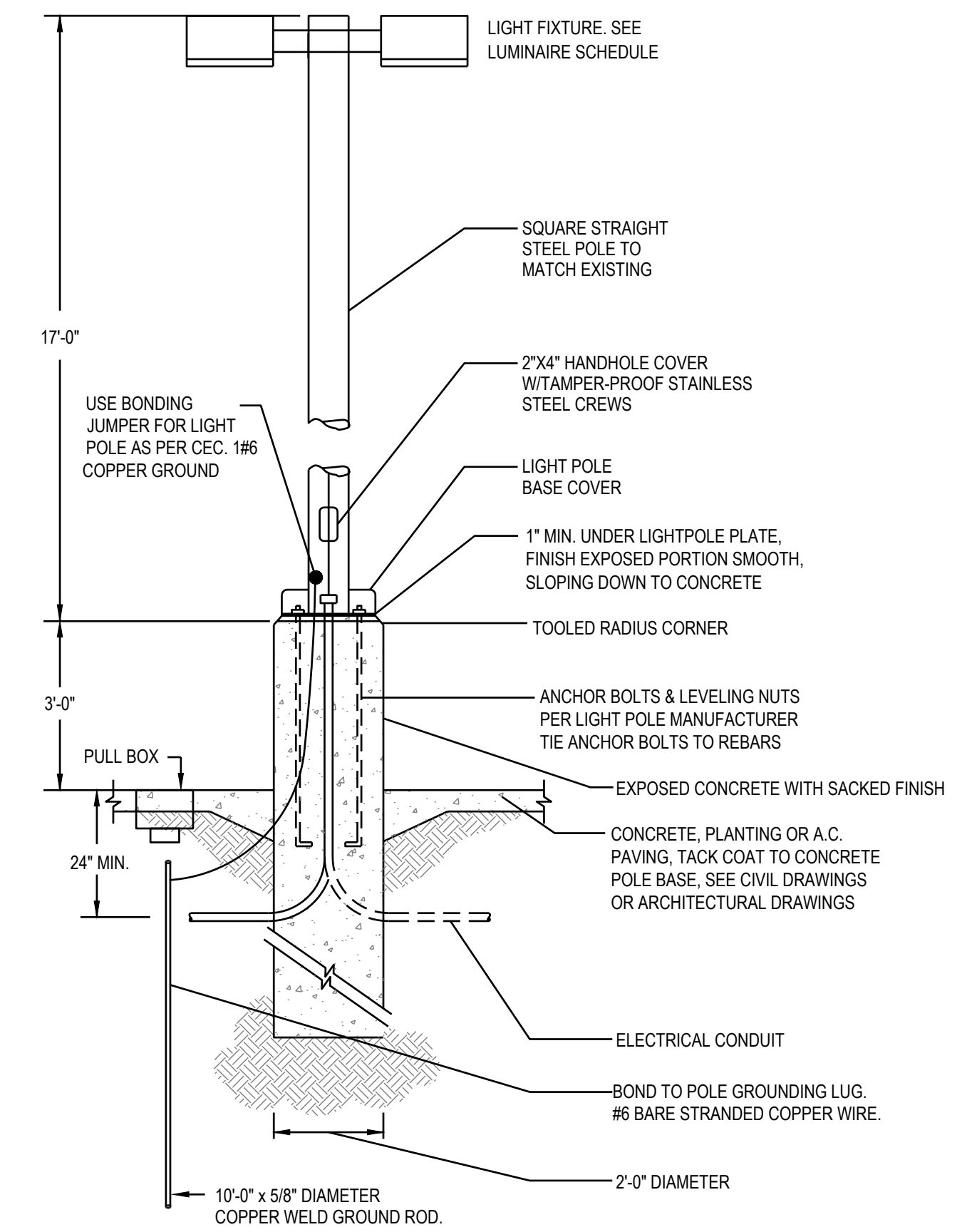

POLE BASE DETAIL
SCALE: N.T.S.

NOTE:
REFER TO STRUCTURAL/ARCHITECTURAL DETAIL FOR ADDITIONAL REQUIREMENT.

PROVIDE A CONCRETE CRISTY BOX WITH TRAFFIC RATED COVER BY EACH LIGHT POLES FOR THE INTERFACE OF CONDUITS



ad
ARMÉT DAVIS NEWLOVE & ASSOCIATES, AIA ARCHITECTS

1330 OLYMPIC BLVD.
SANTA MONICA, CALIFORNIA 90404
PH 310 452-5533 FAX 310 450-4742

THE USE OF THESE PLANS AND SPECIFICATIONS SHALL BE RESTRICTED TO THE ORIGINAL SITE FOR WHICH THEY WERE PREPARED AND PUBLICATION THEREOF IS EXPRESSLY LIMITED TO SUCH USE. RE-USE, REPRODUCTION OR PUBLICATION BY ANY METHOD, IN WHOLE OR IN PART, IS PROHIBITED. TITLE TO THESE PLANS AND SPECIFICATIONS REMAINS WITH THE ARCHITECT WITHOUT PREJUDICE. VISUAL CONTACT WITH THESE PLANS AND SPECIFICATIONS SHALL CONSTITUTE FRAUD. EVIDENCE OF THE ACCEPTANCE OF THE RESTRICTIONS.



Project No: CA3205
Dutch Bros Coffee - New Freestanding Store
DB2550-A1
HIGHWAY 99
GRIDLEY, CA 95948

ACIES ENGINEERING
400 N. McCarthy Blvd., Suite 250
Milpitas, CA 95035
ph: (408)622-5255 | f: (408)622-5260
info@acies.net | Copyright © 2023

DATE: 01/05/2024
REV: DATE: DESCRIPTION:

SHEET NUMBER:

PHOTOMETRIC SITE PLAN

SHEET NUMBER:
E0.02

Imperial Lighting Job: Dutch Bros Descr: Pole Head - Prototypical

AREA LIGHTING

FORM AND FUNCTION

- Sleek, low profile housing
Spec grade performance
Engineered for optimum thermal management
Low depreciation rate
Reduces energy consumption and costs up to 65%
Exceeds IES foot candle levels utilizing the least number of poles and fixtures per project
Optical system designed for:
- Parking Lots
- Auto Dealerships
- General Area Lighting

CONSTRUCTION

- Die Cast Aluminum
External cooling fins, Finite Element Analysis (FEA) designed
Corrosion resistant external hardware
One-piece silicone gasket ensures IP-65 seal for electronics compartment
One-piece Optics Plate* mounting silicone Micro Optics
Two-piece silicone Micro Optic system ensures IP-67 level seal around each PCB
Grade 2 Clear Anodized Optics Plate* standard



- Certified to UL 1598
UL B750
CSA C22.2 No. 250.0
DesignLights Consortium® (DLC)
DesignLights Consortium Premium® (DLCP)
IP65/IP67 Rated
3G Vibration Rated per ANSI C136.31-2010

- 3-5 mils electrostatic powder coat
NLS' standard high-quality finishes prevent corrosion
protects against extreme environmental conditions

WARRANTY

Five-year limited warranty for drivers and LEDs.



LED WATTAGE CHART table with columns for 16L, 32L, 48L, 64L and rows for 350, 500, 700 milliwatts.

Table with columns: Cat #, Light Dist., No. of LEDs, Milliwatts, Kelvin, Volts, Mounting, Color, Options. Includes details for Type 2, 3, 4, 5 fixtures.

OPTICAL CONFIGURATIONS

Rotatable Optics (ROR) Rotated Right, (ROL) Rotated Left options available. Optics field and factory rotatable.

(OPP)

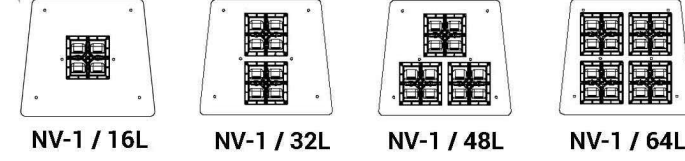

* OPTIC PLATE PAINTED TO MATCH FIXTURE FINISH (OPP) - Optic Plate standard clear anodized, Grade 2. When (OPP) specified, Optic Plate finish will match fixture finish.

LUMENS table with columns for Model Number, No. of LEDs, Milliwatts, Kelvin, Volts, Mounting, Color, Options. Lists various configurations and their lumen outputs.

*DLC S- Standard Pi Premium

EPA

Table with columns: EPA, SGL, D90, D180, T90, T120, QD. Values for NV1-ASA are listed.

L70/L90 DATA

Table with columns: TEMP., L70 (64L-1050mA), L90 (64L-1050mA). Values for NV1-ASA are listed.

MOUNTING OPTIONS

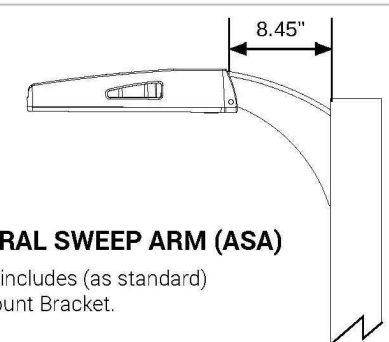

ARCHITECTURAL SWEEP ARM (ASA) Cast Sweep Arm includes (as standard) Internal Quick Mount Bracket.

NLS LIGHTING SQUARE STRAIGHT STEEL POLE

POLES + BASES

SHAFTS

Shaft Shall be Straight Steel Grade B Extrusion with yield of 46,000 PSI. Conforms to ASTM A500 Standards. Poles have ground lug welded inside hand-hole opposite side of the pole extrusion. Pole Extrusion is conjoined to Anchor Base by welding internal to pole shaft and external to pole shaft. Hand Hole reinforcement is constructed of 3" x 5" rectangular steel tubing which is welded to pole shaft for added strength.

ANCHOR BOLTS

All anchor bolts are fully hot dipped galvanized and come with two galvanized nuts and washers per bolt. Anchor bolts are not included for Custom Bolt Circle. Anchor Bolts are "J" style, with a 4" hook at the end for added strength. 3/4" Anchor Bolts are 1/2" diameter x 30 long with a 4" long "J" hook. 1" Anchor Bolts are 1" diameter x 36" long with a 4" long "J" hook.

ANCHOR BASE

Manufactured from A36 Steel rated at 36,000 PSI, conforms the ASTM -A36 standards. Base Plate vary in size from 1" thick for poles 21 feet and over, 3/4" thick for poles 10 to 20 feet.

FINISH

All poles have minimum 3 to 5 mils powder coat finish. All poles are sandblasted prior to powder coat application.

BASE COVER, HAND HOLE COVER AND POLE CAP

All poles come with removable polymer pole cap installed. All pole caps are black finish. All base covers are made of aluminum and powder coated to match the pole. The hand hole covers are provided with internal bridge support and also powder coated to match pole finish.



Table with columns: Cat #, Height, Pole Dim., Size, Base Pattern, Orient, Color, Bolts, Enhancements. Lists various pole configurations and specifications.



1330 OLYMPIC BLVD. SANTA MONICA, CALIFORNIA 90404 PH 310 452-5533 FAX 310 450-4742

THE USE OF THESE PLANS AND SPECIFICATIONS SHALL BE RESTRICTED TO THE ORIGINAL SITE FOR WHICH THEY WERE PREPARED AND PUBLICATION THEREOF IS EXPRESSLY LIMITED TO SUCH USE. RE-USE, REPRODUCTION OR PUBLICATION BY ANY METHOD, IN WHOLE OR IN PART, IS PROHIBITED. TITLE TO THE PLANS AND SPECIFICATIONS REMAINS WITH THE ARCHITECT WITHOUT PREJUDICE. VISUAL CONTACT WITH THESE PLANS AND SPECIFICATIONS SHALL CONSTITUTE FRAUD. MAKE EVIDENCE OF THE ACCEPTANCE OF THE RESTRICTIONS.



Imperial Lighting L7 Job: Dutch Brothers Coffee Descr: Canopy 6" light

Outdoor Cove Lighting CROWN

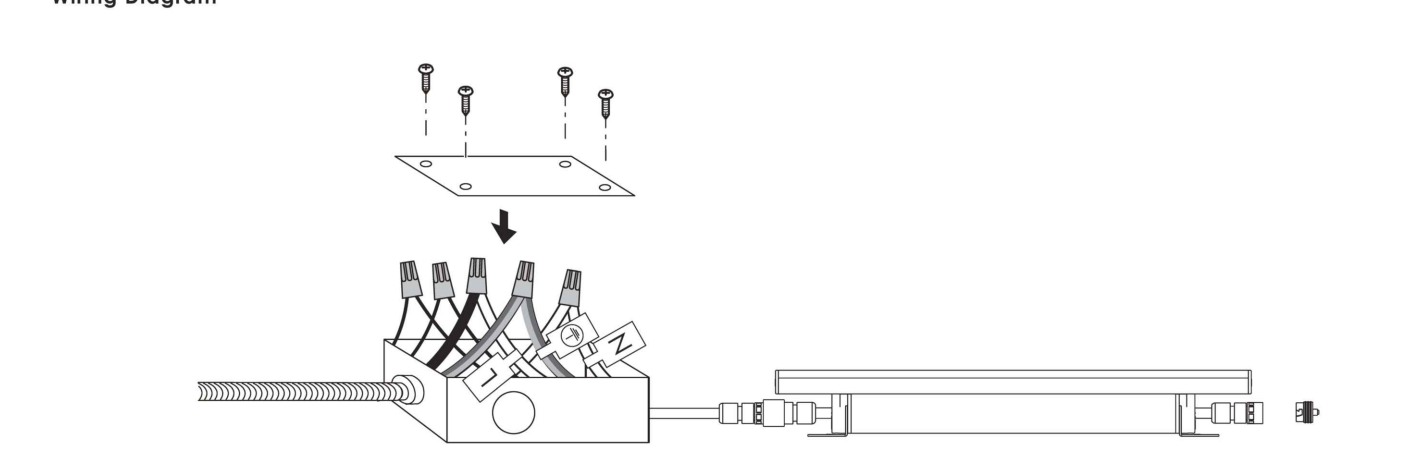
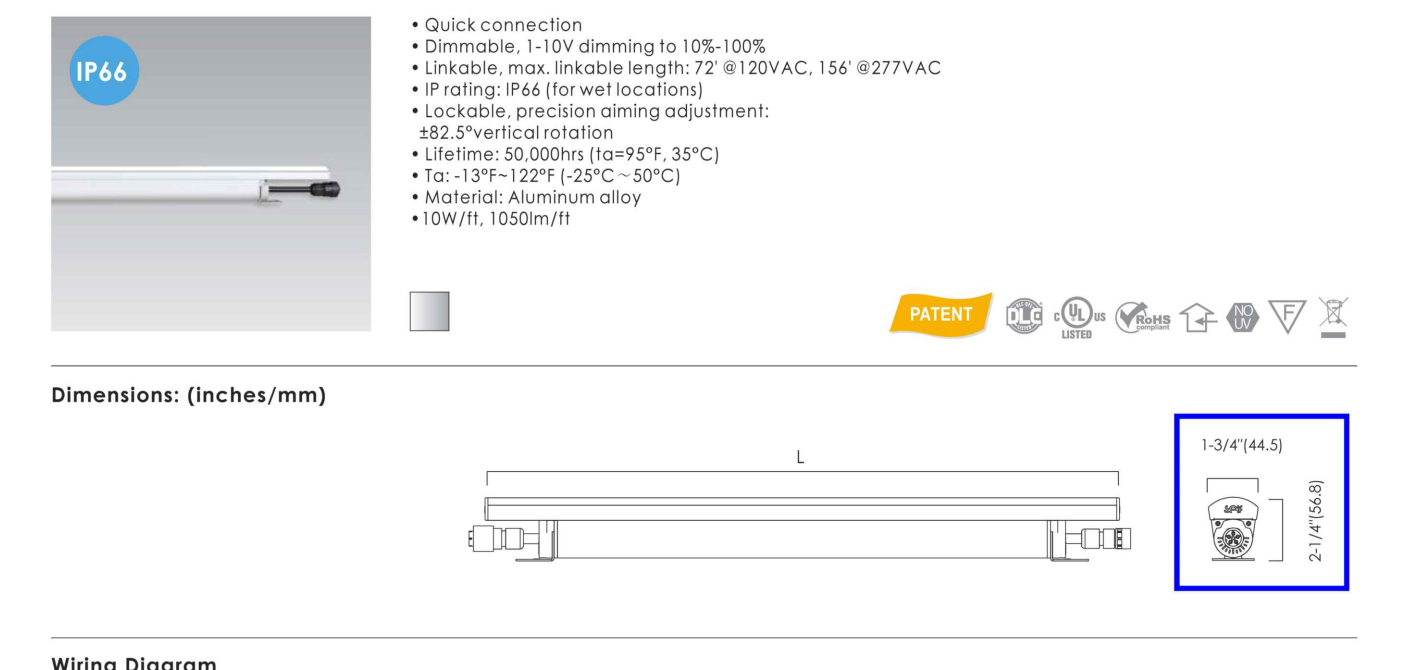

AC connection: Black: "L" White: "N" Yellow/green: "G" Dimming connection: Violet: "+" Gray: "-"

Outdoor Cove Lighting CROWN

How to order using our catalog numbers: Example: CROWN-1230K11055

Table with columns: Series, Length, Color Temp, Beam Angle, Finish, Installation. Values for CROWN-1230K11055 are listed.

Table with columns: Catalog No., Model, Rated Input, Ra, Wattage, Luminous Flux (TYF&GD003), Included. Lists various CROWN models and their specifications.

How to choose your driver & cables:

Table with columns: Catalog No., Description, Photo. Shows C-CROWN-5P input cable 5P.

Optional table with columns: Catalog No., Description, Photo. Shows S-CROWN-12 soft connector 12 and TK-CROWN-79 track 79 including 3pcs screws.

Outdoor Cove Lighting CROWN

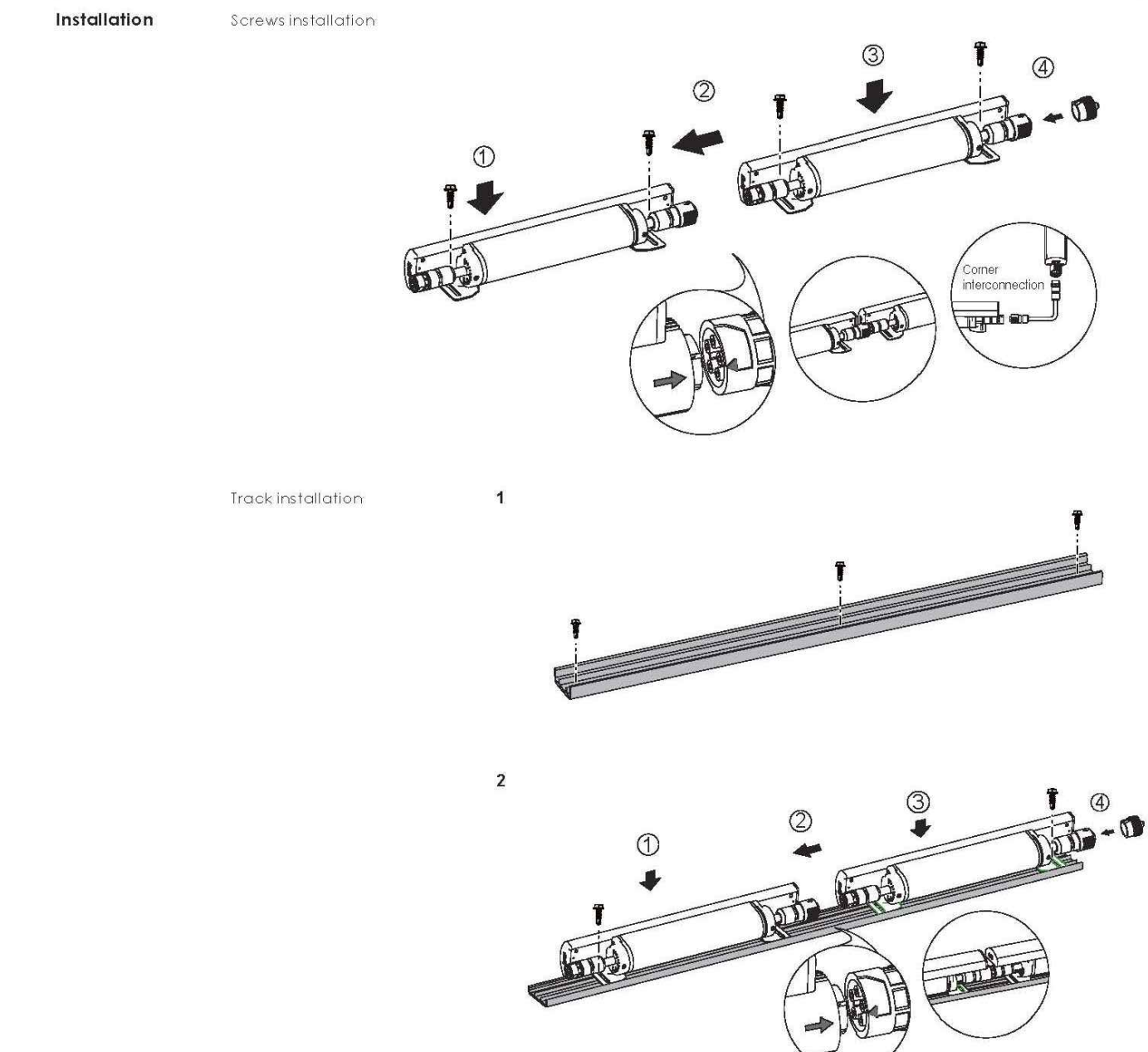

Project No: CA3205 Dutch Bros Coffee - New Freestanding Store DB2550-A1 HIGHWAY 99 GRIDLEY, CA 95948

ACIES ENGINEERING 400 N. McCarthy Blvd. Suite 250 Milpitas CA, 95035

DATE: 01/05/2024 REV: DATE: DESCRIPTION:

SHEET NAME: EXTERIOR LIGHTING CUTSHEETS

SHEET NUMBER: E0.03

UMT-31416-DBNA
Matrix 3 Surface

7144 NE Progress Ct. Hillsboro, Oregon 97124
LIGMAN LIGHTING USA

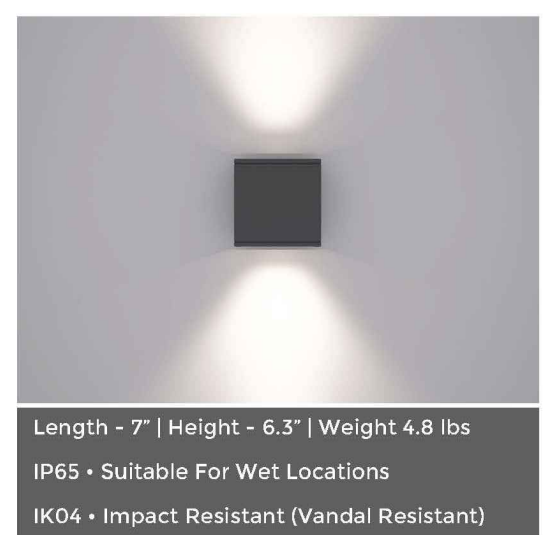

Length - 7" | Height - 6.3" | Weight: 4.8 lbs
IP65 - Suitable For Wet Locations
IK04 - Impact Resistant (Vandal Resistant)

Construction

Aluminum: Less than 0.1% copper content - Marine Grade 6060 extruded & LM5 Aluminum High Pressure die casting provides excellent mechanical strength, clean detailed product lines and excellent heat dissipation.
Pre-paint: 8 step de-grease and phosphate process that includes deoxidizing and etching as well as a zinc and nickel phosphate process before product painting.
Memory Retentive - Silicon Gasket: Provided with special injection molded "fit for purpose" long life high temperature memory retentive silicon gaskets. Maintains the gaskets exact profile and seal over years of use and compression.

Thermal management

LM5 Aluminum is used for its excellent mechanical strength and thermal dissipation properties in low and high ambient temperatures. The superior thermal heat sink design by Ligman used in conjunction with the driver, controls thermal below critical temperature range to ensure maximum luminous flux output, as well as providing long LED service life and ensuring less than 10% lumen depreciation at 50,000 hours.

Surge Suppression

Standard 10kV surge suppressor provided with all fixtures.
BUG Rating
B1 - US - G0

Finishing

All Ligman products go through an extensive finishing process that includes letting to improve paint adherence.

Paint

UV Stabilized 4.9MI thick powder coat paint and baked at 200 Deg C. This process ensures that Ligman products can withstand harsh environments. Rated for use in naturatoriums.

Hardware

Provided Hardware is Marine grade 316 Stainless steel.
Anti-Seize Screw Holes
Tapped holes are infused with a special anti-seize compound designed to prevent seizure of threaded connections, due to electrolysis from heat, corrosive atmospheres and moisture.

Crystal Clear Low Iron Glass Lens

Provided with tempered, impact resistant crystal clear low iron glass ensuring no green glass tinge.
Optics & LED
Precise optic design provides exceptional light control and precise distribution of light. LED CRI > 80

Lumen - Maintenance Life

L80 (B10) at 50,000 hours (This means that at least 90% of the LED still achieve 80% of their original flux)

Square surface wall-mounted architectural lighting range. Family of lighting effects sanctioning imagination and inspiration to reign in designs.

A small profile wall mounted compact cubic luminaire with up and downward light distributions. The Matrix is designed with five light distribution options, namely narrow, medium, wide, very wide and spike.

The Matrix uses high efficiency, long life LEDs and is designed to illuminate the wall and surfaces in front of the wall, as well as light accents on vertical and horizontal surfaces. The Matrix is suitable for indoor and outdoor applications.

This luminaire is available with decorative spikes and can be used with various combinations of light distribution optics.

This luminaire can be mounted at different angles to produce interesting decorative lighting effects on the side of the building facade. The standard Matrix is designed to mount over a 3" octagonal j-box, a 4" j-box cover plate is available upon request.

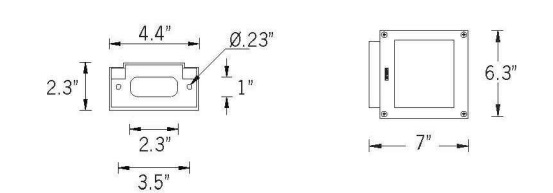
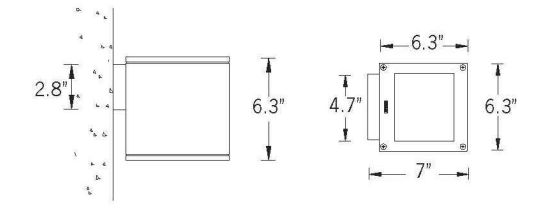

Mounting Detail

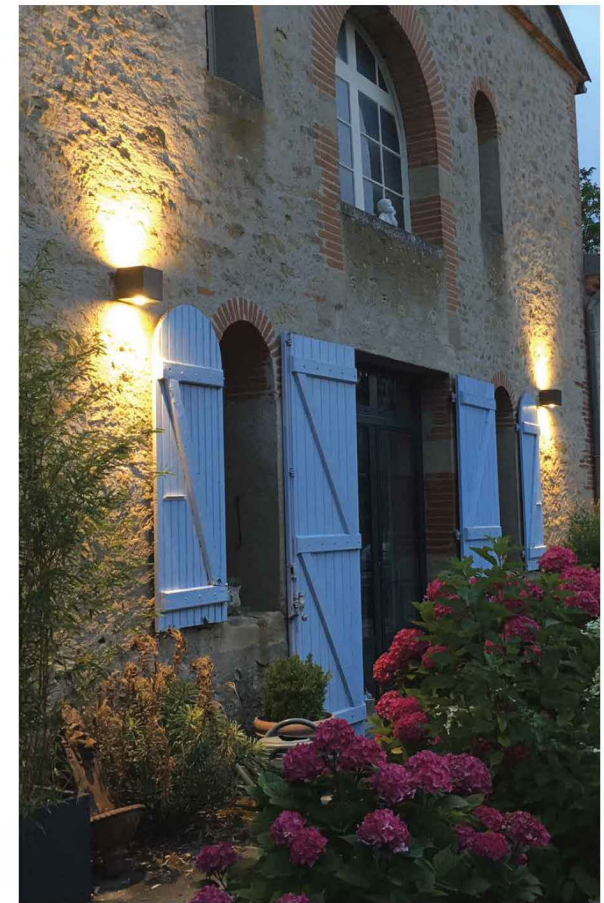
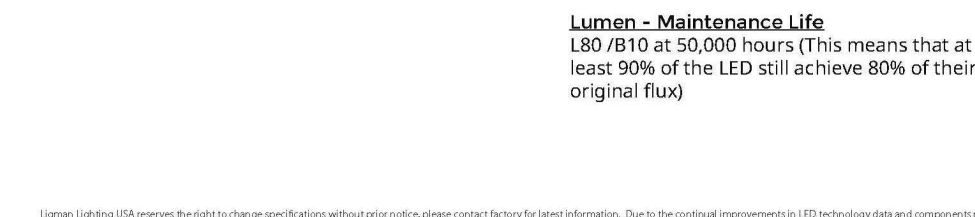

Lighting 100000 Right to change without notice without liability for loss of information. Data the technical improvements in LED technology date and corresponding design without notice.

UMT-31416-DBNA
Matrix 3 Surface

7144 NE Progress Ct. Hillsboro, Oregon 97124
LIGMAN LIGHTING USA

PROJECT	<input type="text"/>	DATE	<input type="text"/>
QUANTITY	<input type="text"/>	TYPE	<input type="text"/>
NOTE	<input type="text"/>		

ORDERING EXAMPLE || UMT - 31416 - 14/14w - W30 - 02 - 120/277v - Options

LAMP	BEAM	LED COLOR	FINISH COLOR	VOLTAGE
<p>1/4" Hw COB</p> <p>1128 Lumens Down</p> <p>1128 Lumens Up</p>	<p>N - Narrow 20"</p> <p>M - Medium 25"</p> <p>W - Wide 36"</p> <p>VW - Very Wide 74"</p>	<p>W27 - 2700K</p> <p>W30 - 3000K</p> <p>W35 - 3500K</p> <p>W40 - 4000K</p>	<p>01 - BLACK RAL 9003</p> <p>02 - DARK GREY RAL 7043</p> <p>03 - WHITE RAL 9003</p> <p>04 - METALLIC SILVER RAL 9006</p> <p>05 - MATTE SILVER RAL 9006</p> <p>06 - LIGMAN BRONZE</p> <p>07 - CUSTOM RAL</p>	<p>120/277v</p> <p>Other - Specify</p>

<input type="text"/>	<input type="text"/>	<input type="text"/>	<input type="text"/>	<input type="text"/>
----------------------	----------------------	----------------------	----------------------	----------------------

ADDITIONAL OPTIONS

NAT - Naturatorium Rated	COLORED DICHOIC FILTERS
F - Frosted Lens	RD - Red Lens
43 - Mounting Plate for 4" Junction Box	BL - Blue Lens
DIM - 0-10V Dimming	GR - Green Lens
	AM - Amber Lens
	(Specify Other Color)

<input type="text"/>	<input type="text"/>	<input type="text"/>
<input type="text"/>	<input type="text"/>	<input type="text"/>

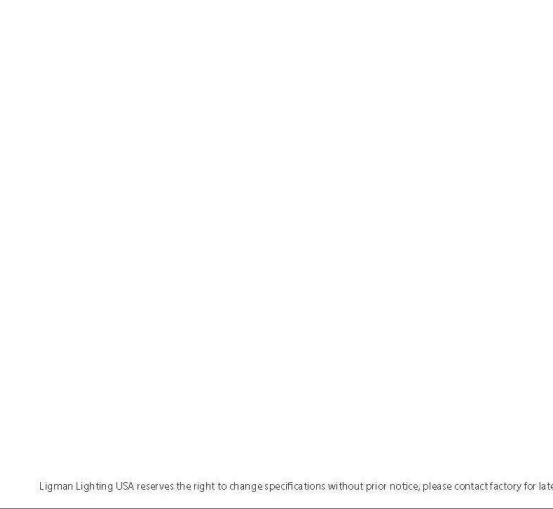

Lighting 100000 Right to change without notice without liability for loss of information. Data the technical improvements in LED technology date and corresponding design without notice.

Imperial Lighting L6

Job: Dutch Brothers Coffee Prototype
Descr: Exterior Wallpack

WPLED26Y/E

RAB



26 Watt LED wallpack with emergency backup battery that will last for 90 minutes during power interruption. Patent Pending thermal management system, 100,000 hour L70 lifespan, 5 Year Warranty.
Color: Bronze Weight: 14.0 lbs

Project:	<input type="text"/>	Type:	<input type="text"/>
Prepared By:	<input type="text"/>	Date:	<input type="text"/>

Driver Info		LED Info	
Type:	Constant Current	Watts:	26W
120V:	0.25A	Color Temp:	3000K
208V:	0.15A	Color Accuracy:	71 CRI
240V:	0.14A	L70 Lifespan:	100000
277V:	0.12A	Lumens:	3298
Input Watts:	26W	Efficiency:	112 LPW
Efficiency:	89%		

Technical Specifications

Other

Battery Backup:
Minimum starting temperature is 0°C/32°F.
The WPLED design is protected by U.S. Patent D634878 and Patents pending in the U.S., Canada, China, Taiwan and Mexico.
Equivalency: Equivalent to 175W Metal Halide.
FTC Country of Origin: This product was assembled in the USA by RAB using imported components.
Buy American Act Compliance: This product complies with the Buy American Act.
Listings:
DLC Listed: This product is on the Design Light Consortium (DLC) Qualified Products List and is eligible for rebates from DLC Member Utilities.
DLC Product Code: P00001750
UL Listing: Suitable for Wet Locations as downlight, Wall Mount, Only. Battery Backup UL 524 Listed Emergency Lighting Power Supply.

LED Characteristics

Lifespan: 100,000-hour LED lifespan based on IES LM-80 results and TM-21 calculations.
LED: Two (2) 13W high-output, long-life LEDs.
Color Consistency: 3-step MacAdam Ellipse binning to achieve consistent future-to-future color.
Color Stability: LED color temperature is warranted to shift no more than 20K in CCT over a 5-year period.
Color Uniformity: RAB's range of CCT (Correlated Color Temperature) follows the guidelines of the American National Standard for Specifications for the Chromaticity of Solid State Lighting (SSL) Products, ANSI C78.377-2017.
Electrical

Battery Mode: Light output uses LLD of 76 to simulate light output during battery mode operation.
Driver: Constant Current, Class 2, 50/60 Hz, 120 - 277VAC, 0.4 Amps.

Battery Backup

Backup Battery: Two 6.6Ah-rechargeable, high-temperature, maintenance-free, nickel-cadmium batteries.
Construction

Ambient Temperature: Suitable for use in 35°C (95°F) ambient temperatures.
Gaskets: High temperature silicons.
Housing: Precision die-cast aluminum housing, lens frame and mounting arm.
Finish: Formulated for high-durability and long lasting color.
Green Technology: Mercury and UV free, RoHS compliant components. Polyester powder coat finish formulated without the use of VOC or toxic heavy metals.
Optical

Beam: B1 U0 G0

Need help? Tech help line: (888) RAB-1000 Email: sales@rabweb.com Website: www.rabweb.com
Copyright © 2018 RAB Lighting Inc. All Rights Reserved. Note: Specifications are subject to change at any time without notice.

DRD5S & SurfaceFrame

Surface Mount LED Downlight
New Construction
DRDHJJO Octagonal Junction Box

Project:	<input type="text"/>	Type:	<input type="text"/>
Product Code:	<input type="text"/>	Date:	<input type="text"/>

Spec Sheet V-01.10.22



- Thinnest-in-class DRD5S delivers the pure, smooth light and the elegant look of a high-end recessed downlight
- Features multiple ratings to meet the demands of a wide range of situations
- Ultra-low profile allows it to install in as little as 2" of ceiling space when 5/8" drywall is used

Application New Construction	Aperture 4" Octagonal Junction Box
Delivered Lumens 750 lm (9.0W), 1000 lm (12.0W)	Color Quality 90+ CRI, < 3-step SDCM
Color Temperature	Optics General
<input type="radio"/> 2700K <input type="radio"/> 3000K <input type="radio"/> 3500K	Emergency Lighting Optional Emergency LED Driver with Integrated Test Switch for lighting up to 90 minutes in event of power failure
Input Voltage 120V only (TRIAC/ELV), 120/277V (0-10V)	Dimming TRIAC/ELV 5% 0-10V 1%
Shape Round, Square	Finish White
Housing Ratings	Module Ratings
<input type="checkbox"/> Code compliant for use in appropriate fire-rated assemblies up to a maximum of 2-hours <input type="checkbox"/> STC/IC Sound Rated <input type="checkbox"/> ASTM E283 Certified Air Tight <input type="checkbox"/> IC (Insulation Contact) Rated	<input type="checkbox"/> UL Closet Rating Compliant (90 min only) <input type="checkbox"/> UL Listed for Wet Location
Standards <input type="checkbox"/> IAB <input type="checkbox"/> IEEE <input type="checkbox"/> UL LISTED	Guarantee 50,000 hrs 5 years
	Additional Options <input type="checkbox"/> Non-Conductive Dead Front

dmflighting.com



DRD5S & SurfaceFrame
Surface Mount LED Downlight
General New Construction
DRDHJJO Octagonal Junction Box

PRODUCT BUILDER

PRODUCT CODE	APPLICATION	APERTURE	OPTION
DRDH	Housing	N New Construction	JO SurfaceFrame Octagonal Junction Box
			[Blank] Integrated Driver
			70SEM EM Driver*, 0-10V, 750 lm
			100SEM EM Driver*, 0-10V, 1000 lm

PRODUCT CODE	APERTURE	SHAPE	LUMENS	CRI	GCT	DRIVER
DRD5S	Module	4 4" Aperture	Round	07 750 lm	9 90+ CRI	27 2700K
			S Square	10 1000 lm		30 3000K
						35 3500K
						T Integrated TRIAC/ELV, 120V only
						O Integrated 0-10V, 120/277V
						TDF Integrated TRIAC/ELV, 120V only, Non-Conductive*
						ODF Integrated 0-10V, 120/277V, Non-Conductive*
						EM Emergency w/ Test Switch

* EM option (housing) and Emergency driver (module) must be selected together
* Only available for Round shape, 750 lm, 2700K or 3000K CCT

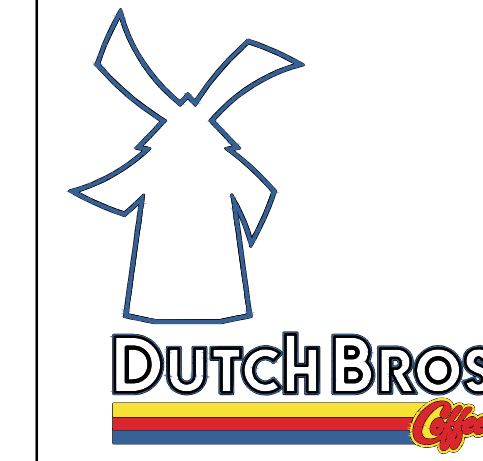

1330 OLYMPIC BLVD.
SANTA MONICA, CALIFORNIA 90404
PH 310 452-5533 FAX 310 450-4742

THE USE OF THESE PLANS AND SPECIFICATIONS SHALL BE RESTRICTED TO THE ORIGINAL SITE FOR WHICH THEY WERE PREPARED AND PUBLICATION THEREOF IS EXPRESSLY LIMITED TO SUCH USE. RE-USE, REPRODUCTION OR PUBLICATION BY ANY METHOD, IN WHOLE OR IN PART, IS PROHIBITED. TITLE TO THE PLANS AND SPECIFICATIONS REMAINS WITH THE ARCHITECT WITHOUT PREJUDICE. VISUAL CONTACT WITH THESE PLANS AND SPECIFICATIONS SHALL CONSTITUTE PRIMA FACIE EVIDENCE OF THE ACCEPTANCE OF THE RESTRICTIONS.



Project No: CA3205
Dutch Bros Coffee - New Freestanding Store
DB2550-A1
HIGHWAY 99
GRIDLEY, CA 95948

ACIES ENGINEERING
400 N. McCarthy Blvd., Suite 250
Milpitas, CA 95035
ph: (408) 622-5255 | fx: (408) 622-5260
info@acies.net | Copyright © 2023

DATE:	01/05/2024
REV:	DATE: DESCRIPTION:

SHEET NAME:
EXTERIOR LIGHTING CUTSHEETS

SHEET NUMBER:
E0.04

SUMMARY - BUILDING SIGNS & MENUS



89975 Prairie Rd.
Eugene, OR 97402
541.485.5546 | esasigns.com

SUMMARY DRAWING:
37040

CLIENT:
Dutch Bros - CA3205
Hwy 99 & Archer Ave.
Gridley, CA 95948

DATE OF SHOP DRAWING:
11/28/23

PROD. DETAILS: CH

LEAD DESIGN: CH

SALES: NJ

REVISIONS:
12.28.23 Changed monument to a pylon.
1.16.24 Change elevations.
1.18.24 Change site plan.

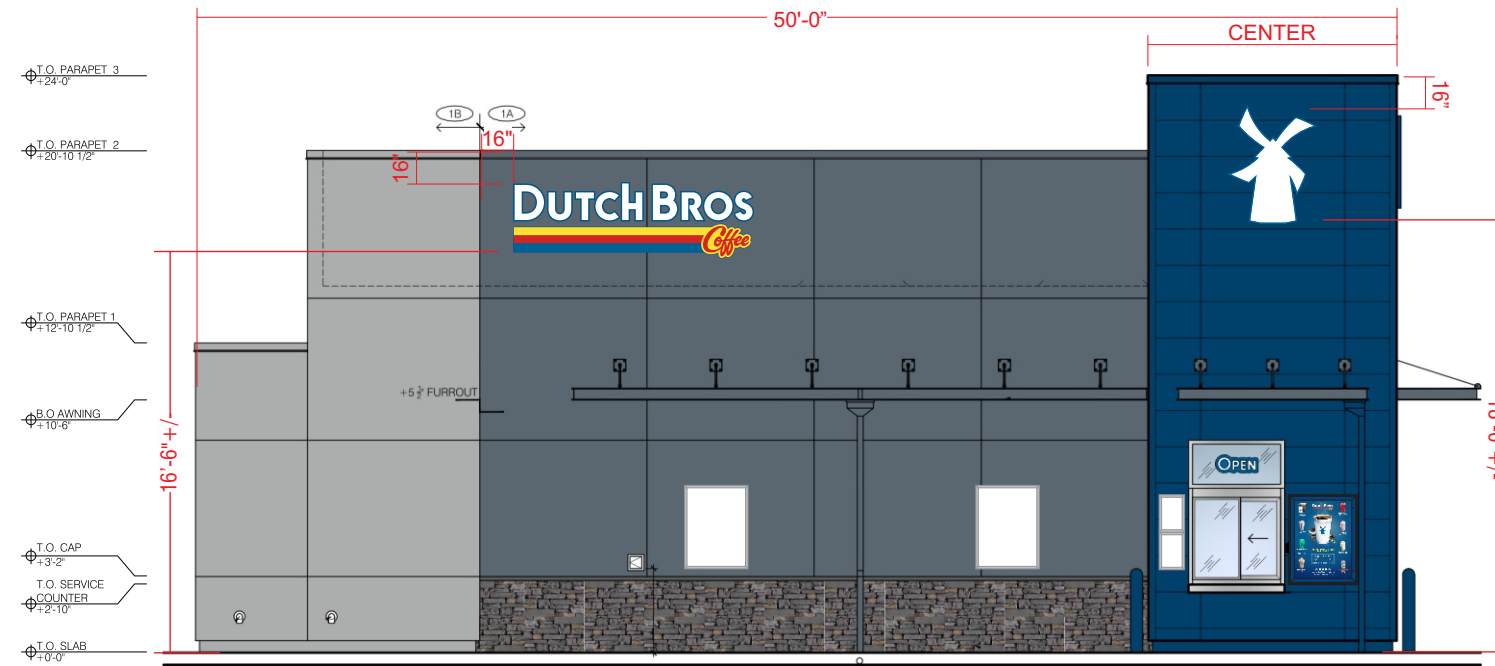

NORTH ELEVATION
SCALE: 1/8"=1'-0"

DBCL10 @ 31.5 SF

DBW13 @ 18.4 SF

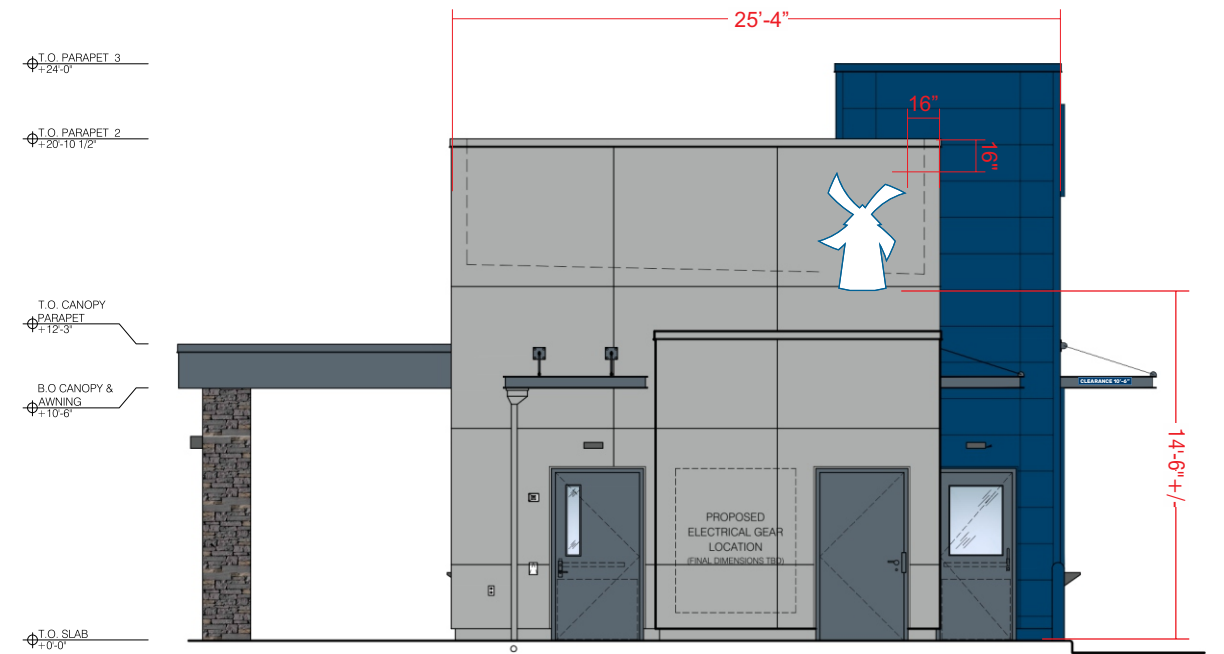

EAST ELEVATION
SCALE: 1/8"=1'-0"

DBW13 @ 18.4 SF

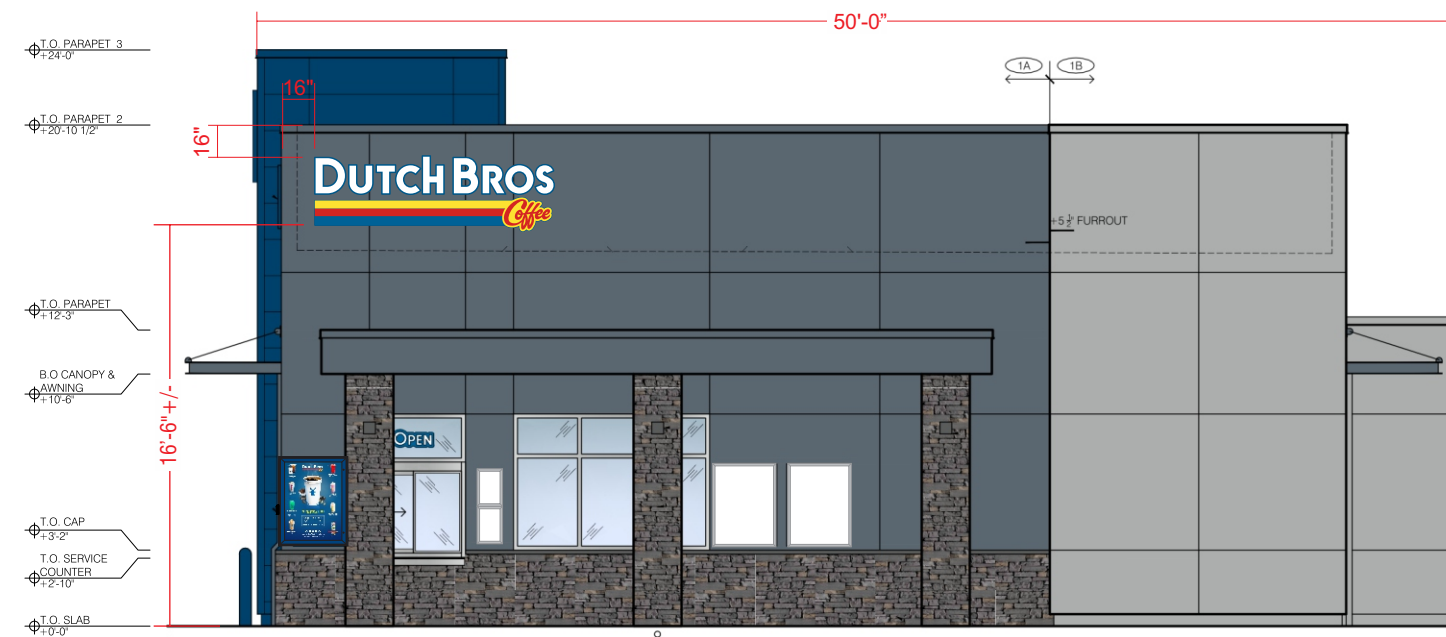

SOUTH ELEVATION
SCALE: 1/8"=1'-0"

DBCL10 @ 31.5 SF

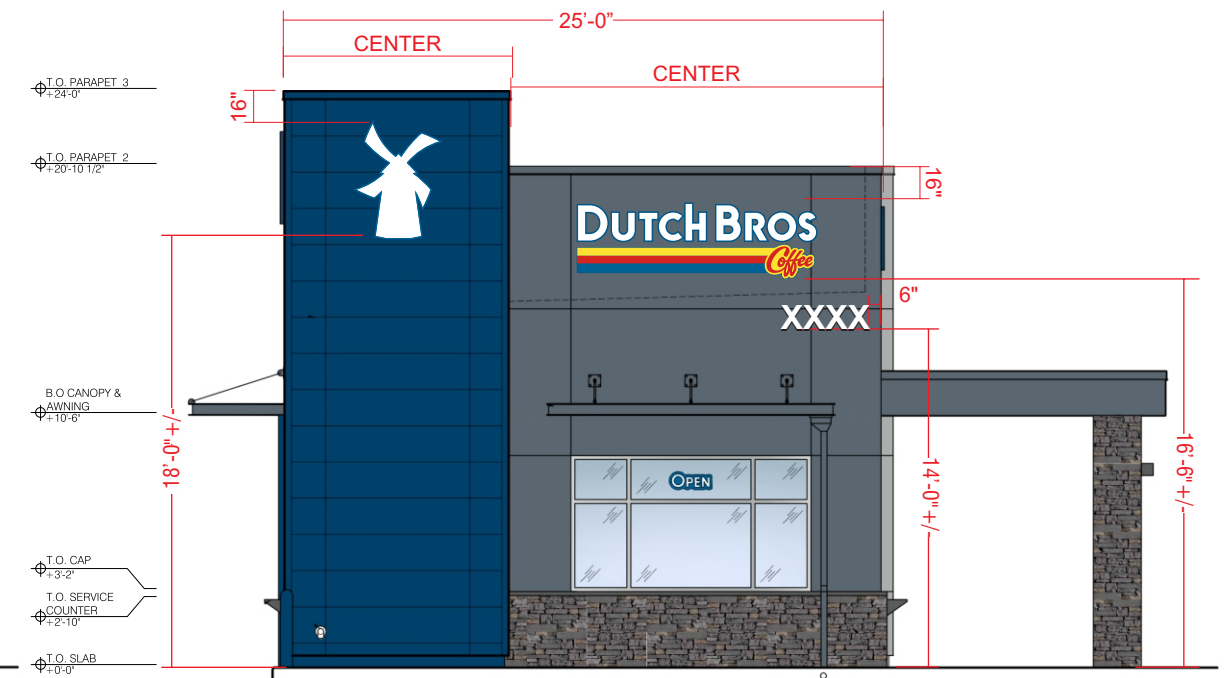

WEST ELEVATION
SCALE: 1/8"=1'-0"

DBW13 @ 18.4 SF

DBCL10 @ 31.5 SF

SUMMARY - FREESTANDING SIGNS & MENUS

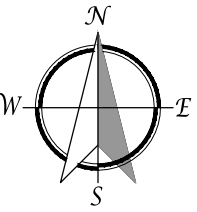

89975 Prairie Rd.
Eugene, OR 97402
541.485.5546 | esasigns.com

SUMMARY DRAWING:
37040

CLIENT:
Dutch Bros - CA3205
Hwy 99 & Archer Ave.
Gridley, CA 95948

DATE OF SHOP DRAWING:
11/28/23

PROD. DETAILS: CH
LEAD DESIGN: CH
SALES: NJ

REVISIONS:
12.28.23 Changed monument to a pylon.
1.16.24 Change elevations.
1.18.24 Change site plan.

STATE HIGHWAY 99

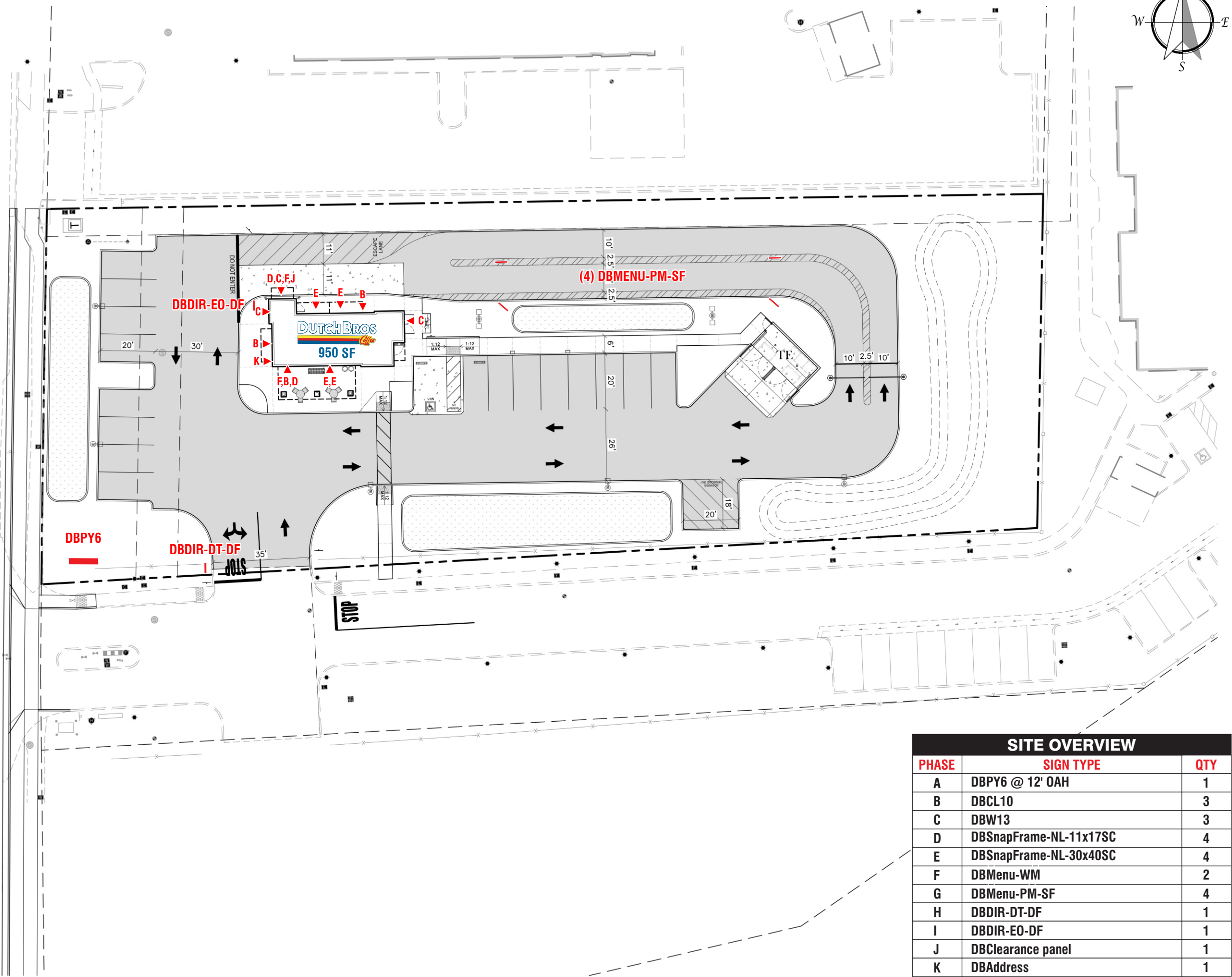

SITE OVERVIEW		
PHASE	SIGN TYPE	QTY
A	DBPY6 @ 12' OAH	1
B	DBCL10	3
C	DBW13	3
D	DBSnapFrame-NL-11x17SC	4
E	DBSnapFrame-NL-30x40SC	4
F	DBMenu-WM	2
G	DBMenu-PM-SF	4
H	DBDIR-DT-DF	1
I	DBDIR-EO-DF	1
J	DBCclearance panel	1
K	DBAddress	1

SCOPE OF WORK: MANUFACTURE & INSTALL ONE (1) D/F INTERNALLY ILLUMINATED PYLON CUP SIGN



89975 Prairie Rd.
Eugene, OR 97402
541.485.5546 | esasigns.com

SHOP DRAWING #:
37040A1

CLIENT:
Dutch Bros - CA3205
Hwy 99 & Archer Ave.
Gridley, CA 95948

DATE OF SHOP DRAWING:
11/28/23

PROD. DETAILS: CH

LEAD DESIGN: CH

SALES: NJ

REVISIONS:
12.28.23 Changed from a
4x10 monument.

COLOR CODE

- PANTONE 107 C YELLOW
- PANTONE 1795 C RED
- PANTONE 7691 C BLUE
- DB CUSTOM DK BLUE (POLE)
- WHITE
- 230-36 DARK BLUE (LID)
- 230-127 INTENSE BLUE (LID)
- 230-147 DEEP SKY BLUE (LID)

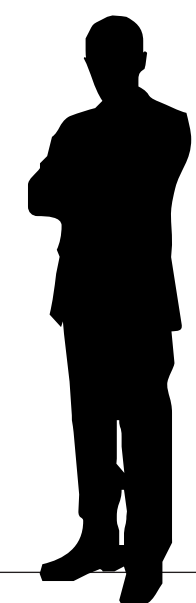
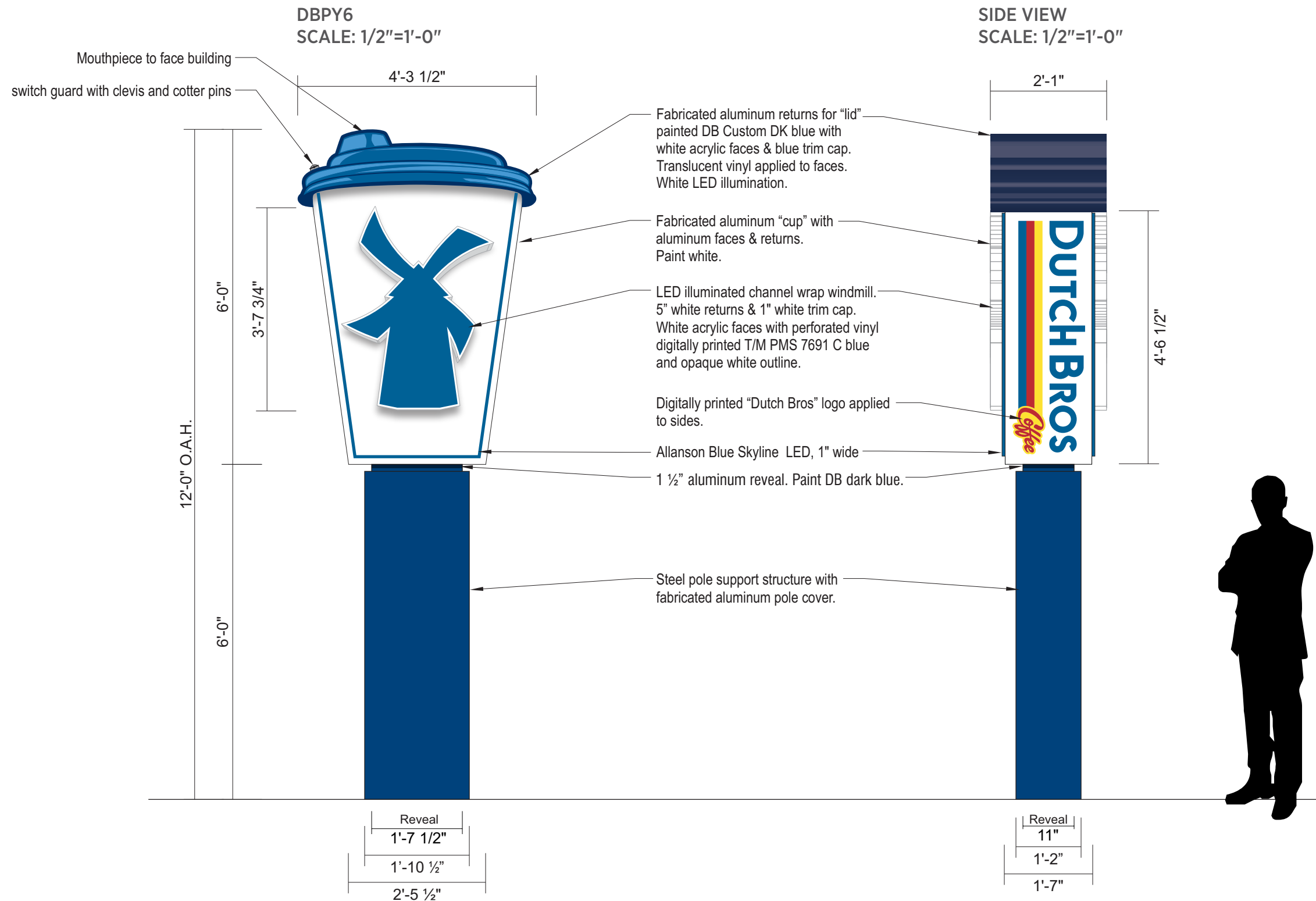

POLE & FOOTING DETAIL

SCALE: 1/2"=1'-0"



89975 Prairie Rd.
Eugene, OR 97402
541.485.5546 | esasigns.com

SHOP DRAWING #:
37040A1

CLIENT:
Dutch Bros - CA3205
Hwy 99 & Archer Ave.
Gridley, CA 95948

DATE OF SHOP DRAWING:
11/28/23

PROD. DETAILS: CH

LEAD DESIGN: CH

SALES: NJ

REVISIONS:
12.28.23 Changed from a
4x10 monument.

SADDLE DETAIL - PLAN VIEW

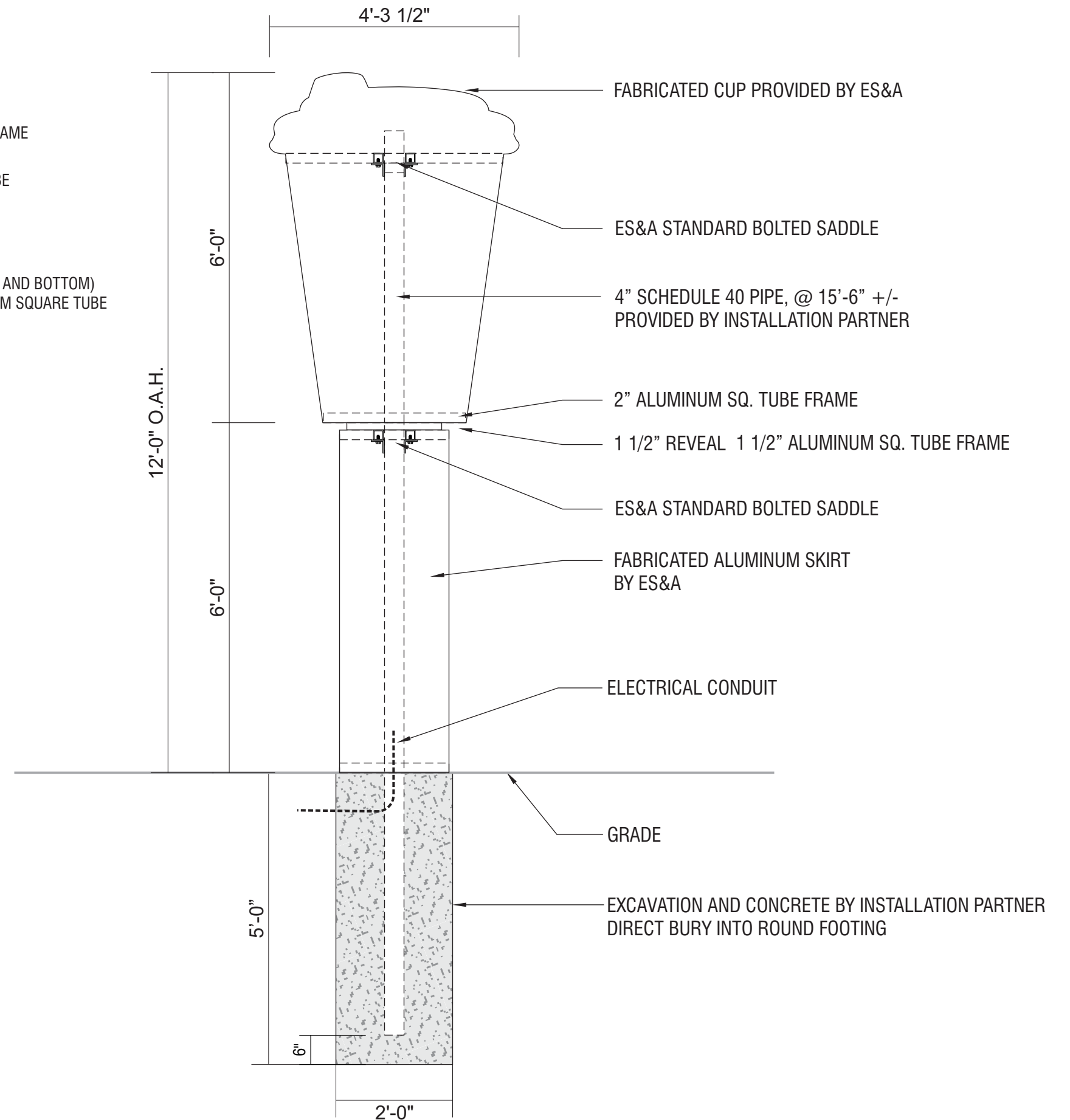
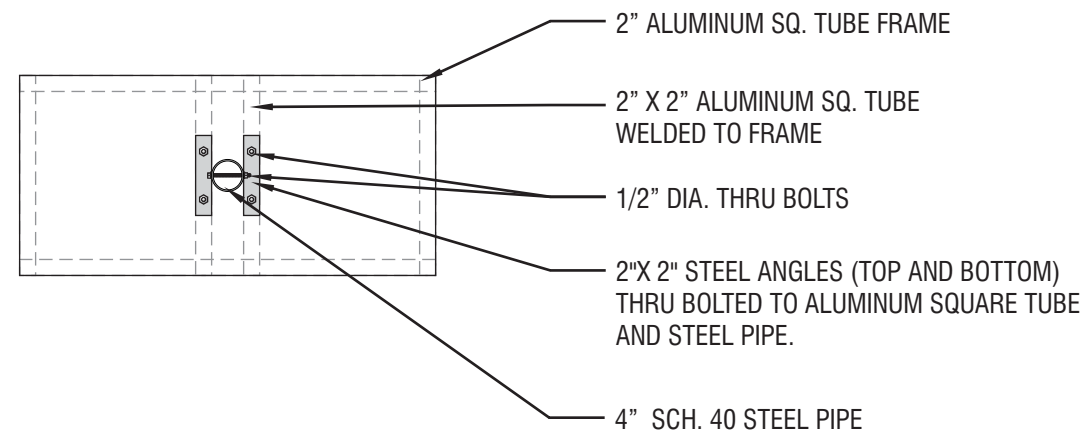

SCOPE OF WORK: MANUFACTURE & INSTALL (3) SETS OF ILLUMINATED CHANNEL LETTERS WITH REMOTE RACEWAYS



89975 Prairie Rd.
Eugene, OR 97402
541.485.5546 | esasigns.com

SHOP DRAWING #:
37040B

CLIENT:
Dutch Bros - CA3205
Hwy 99 & Archer Ave.
Gridley, CA 95948

DATE OF SHOP DRAWING:
11/28/23

PROD. DETAILS: CH

LEAD DESIGN: CH

SALES: NJ

REVISIONS:

COLOR CODE

- 230-015 YELLOW PSV
- 230-33 RED PSV
- 230-127 INTENSE BLUE
- WHITE ACRYLIC

DBCL10-REMOTE RW
SCALE: 3/4"=1'-0"

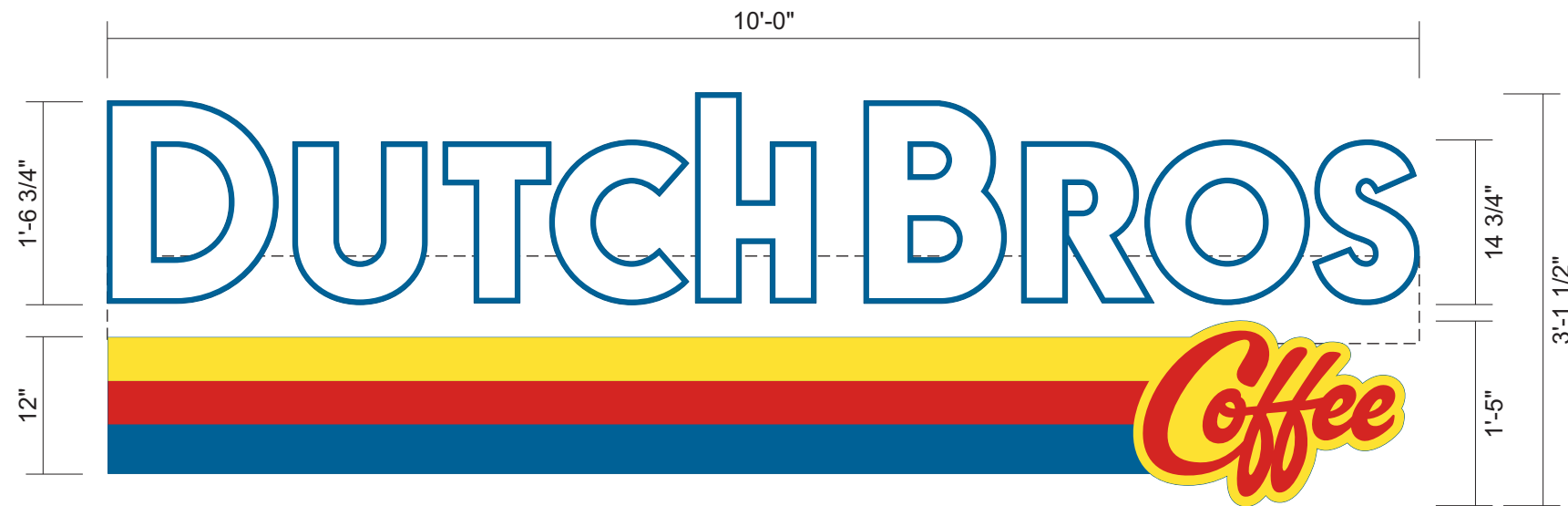

SIDE VIEW



FABRICATED REMOTE RACEWAY
.040 PRE-COAT WHITE ALUMINUM

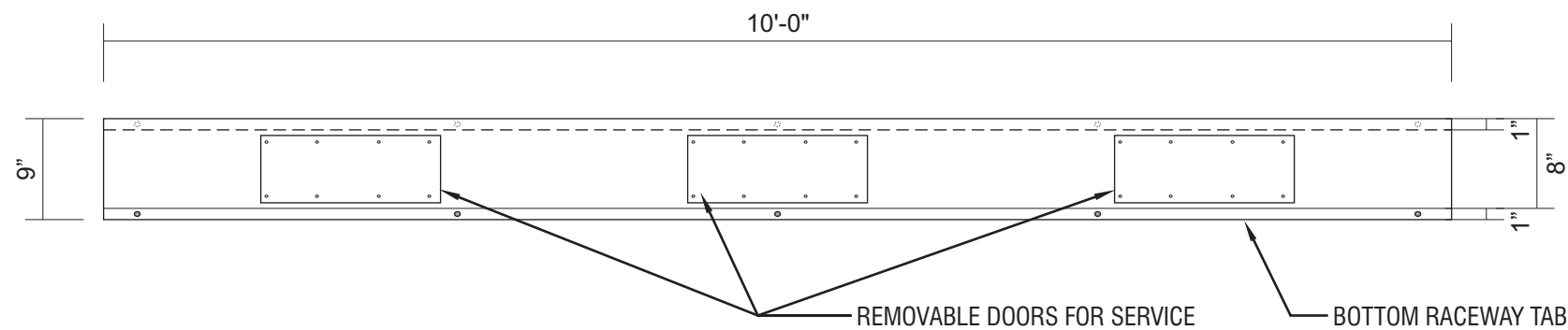

ATTACHMENT DETAIL
CHANNEL LETTERS WITH REMOTE RACEWAY

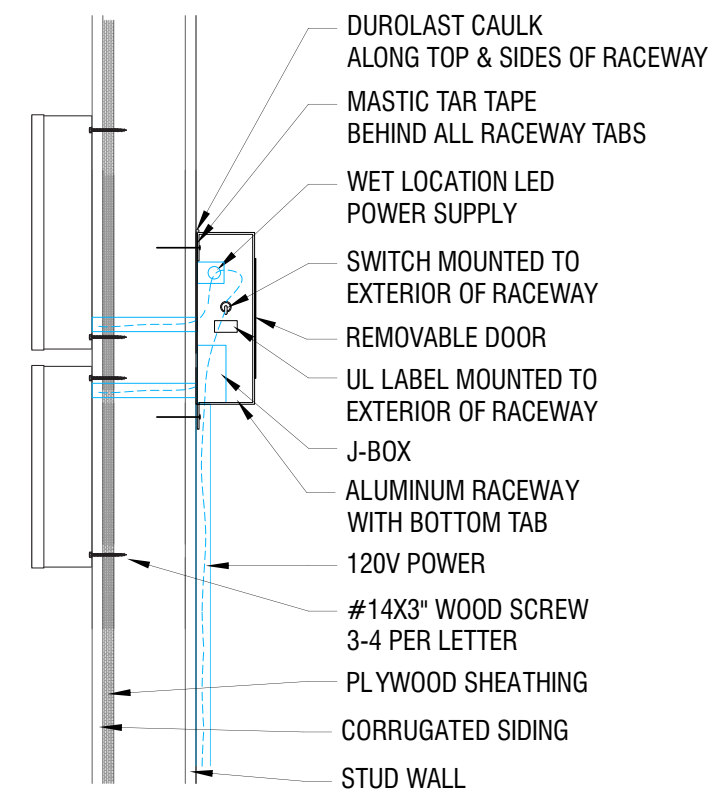

INTERNALLY ILLUMINATED FACE-LIT FLUSH MOUNTED CHANNEL LETTERS
5" DEEP CHANNEL LETTERS.
RETURNS & TRIM CAP PAINTED TO MATCH PANTONE 7691 C "INTENSE BLUE".
WHITE ACRYLIC FACES.
230-127 INTENSE BLUE PSV, 230-015 YELLOW PSV, 230-33 RED PSV.
LED ILLUMINATION.
FLUSH MOUNTED CHANNEL LETTERS WITH REMOTE MOUNTED RACEWAY.
RACEWAY SHALL HAVE A CAULKING APPLIED ALONG THE TOP AND SIDES.
ALL HOLE PENETRATIONS WILL BE SEALED WITH CAULKING.



89975 Prairie Rd.
Eugene, OR 97402
541.485.5546 | esasigns.com

SHOP DRAWING #:
37040C

CLIENT:
Dutch Bros - CA3205
Hwy 99 & Archer Ave.
Gridley, CA 95948

DATE OF SHOP DRAWING:
11/28/23

PROD. DETAILS: CH

LEAD DESIGN: CH

SALES: NJ

REVISIONS:

COLOR CODE

 230-127 INTENSE BLUE

 WHITE

DBW13
SCALE: 3/4"=1'-0"

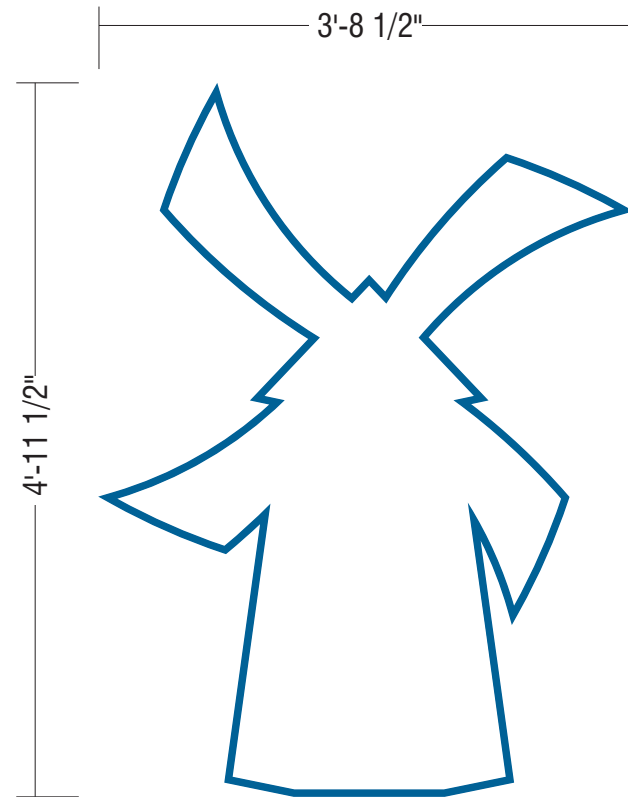

ATTACHMENT DETAIL
SECTION VIEW

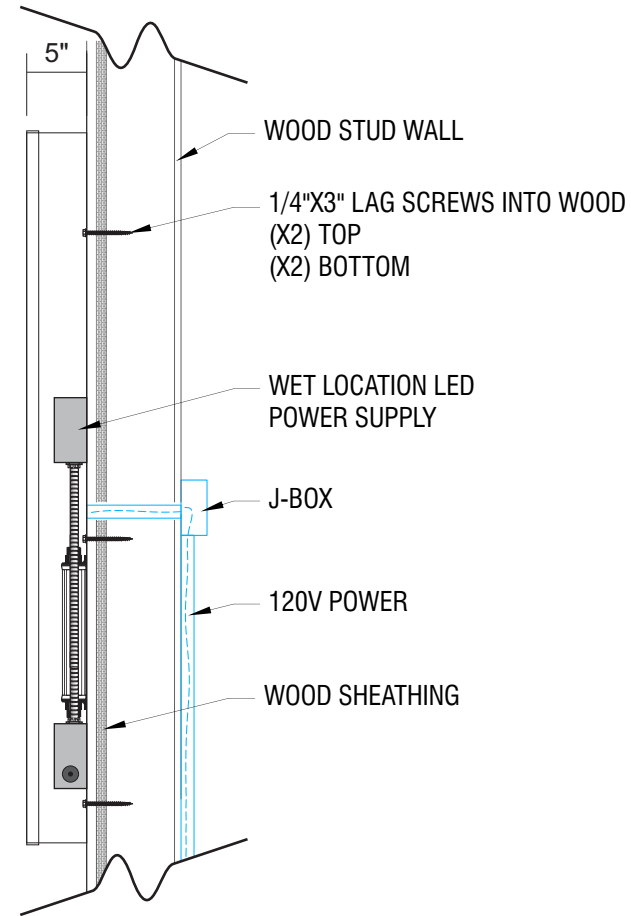

CHANNEL LOGO
SELF CONTAINED

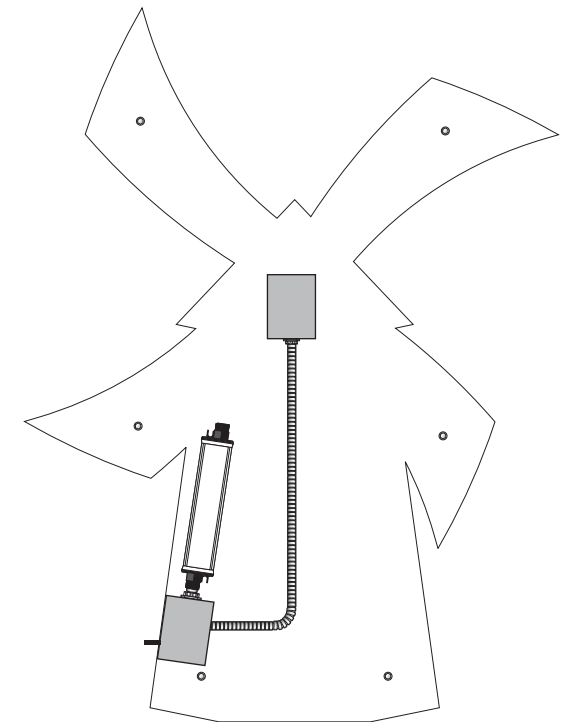

INTERNALLY ILLUMINATED FACE-LIT FLUSH MOUNTED CHANNEL WRAP LOGO
5" DEEP CHANNEL WRAP.
RETURNS & TRIM CAP PAINTED TO MATCH PANTONE 7691 C "INTENSE BLUE".
WHITE ACRYLIC FACE.
230-127 INTENSE BLUE PSV OUTLINE.
LED ILLUMINATION.
FLUSH MOUNTED SELF CONTAINED INSTALLATION.

SCOPE OF WORK: MANUFACTURE & INSTALL (4) SNAP FRAMES



89975 Prairie Rd.
Eugene, OR 97402
541.485.5546 | esasigns.com

SHOP DRAWING #:
37040D

CLIENT:
Dutch Bros - CA3205
Hwy 99 & Archer Ave.
Gridley, CA 95948

DATE OF SHOP DRAWING:
11/28/23

PROD. DETAILS: CH

LEAD DESIGN: CH

SALES: NJ

REVISIONS:

COLOR CODE

 CLEAR ANODIZED ALUMINUM

LAYOUT
SCALE: 1 1/2"=1'-0"

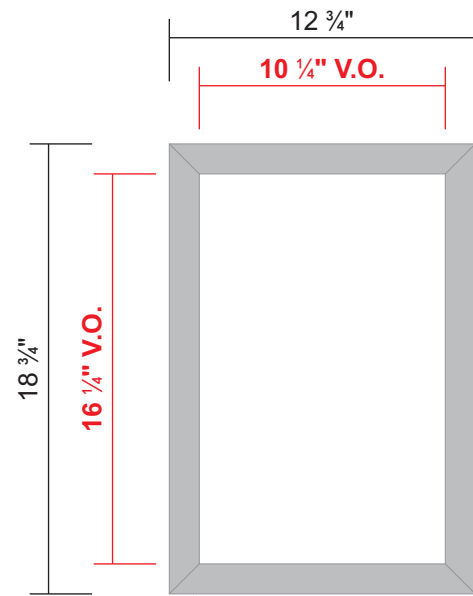

SIGN COMP CLEAR ANODIZED ALUMINUM
SNAP FRAME FOR A 11" X 17" POSTER

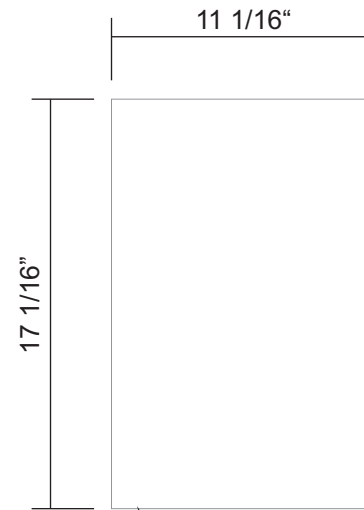

.063 PRE-COAT WHITE ALUMINUM INSERT/BACK

DETAIL:
FULL SCALE

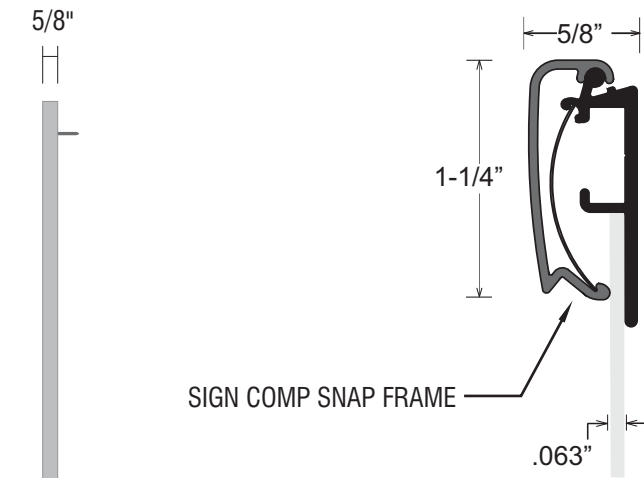

SIGN COMP SNAP FRAME
SCREW TO EXTERIOR WALL OF BUILDING

ELEVATION:
WALK-UP WINDOW
SCALE: 1/8"=1'-0"



(UNLESS OTHERWISE DIRECTED)
CENTERED BETWEEN MULLIONS 2" ABOVE STONE CAP
1" VERTICAL GAP BETWEEN SNAP FRAMES

ELEVATION:
DRIVE-THRU WINDOW
SCALE: 1/8"=1'-0"

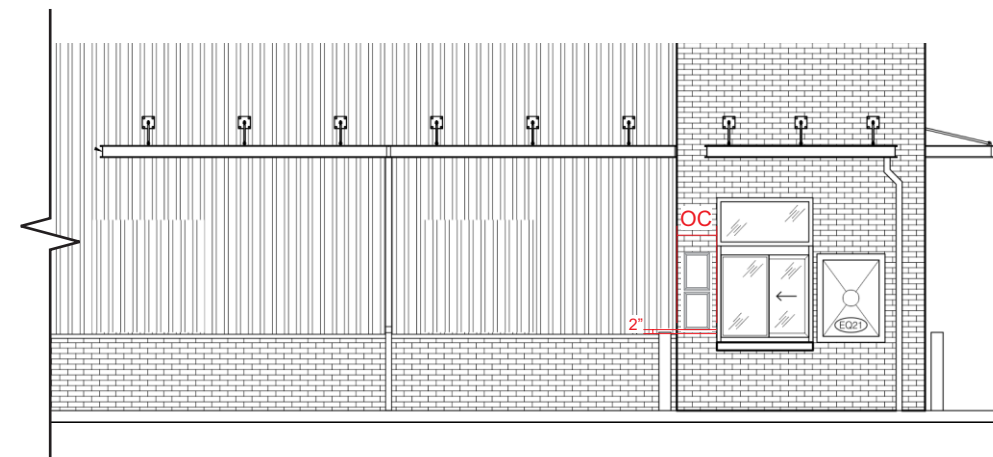

(UNLESS OTHERWISE DIRECTED)
CENTERED BETWEEN MULLIONS 2" ABOVE STONE CAP
1" VERTICAL GAP BETWEEN SNAP FRAMES

SCOPE OF WORK: MANUFACTURE & INSTALL (4) SNAP FRAMES



89975 Prairie Rd.
Eugene, OR 97402
541.485.5546 | esasigns.com

SHOP DRAWING #:
37040E

CLIENT:
Dutch Bros - CA3205
Hwy 99 & Archer Ave.
Gridley, CA 95948

DATE OF SHOP DRAWING:
11/28/23

PROD. DETAILS: CH

LEAD DESIGN: CH

SALES: NJ

REVISIONS:

COLOR CODE

 CLEAR ANODIZED ALUMINUM

LAYOUT
SCALE: 1"=1'-0"

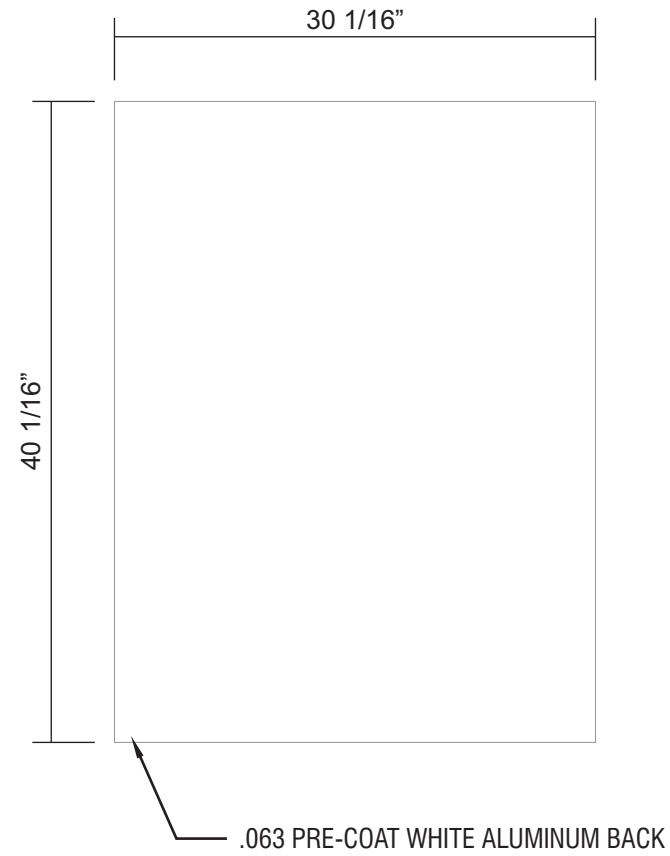
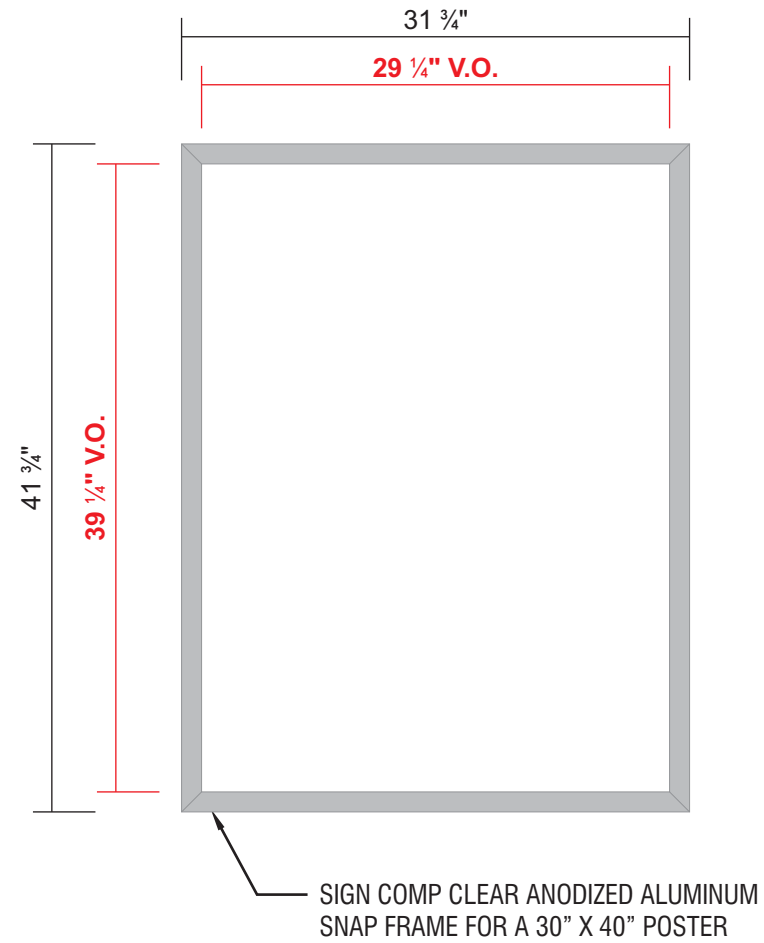

DETAIL:
FULL SCALE

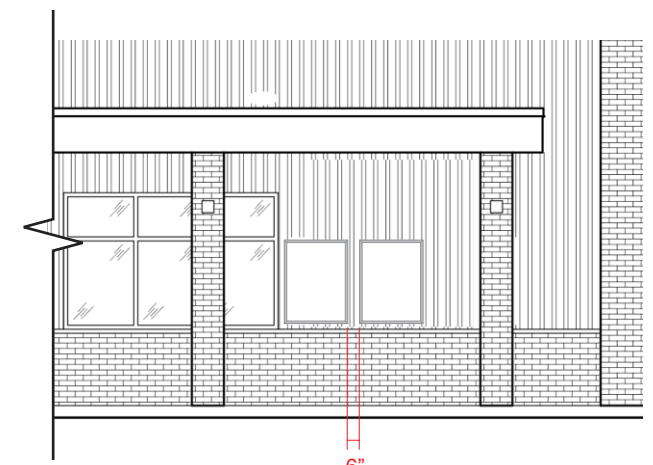
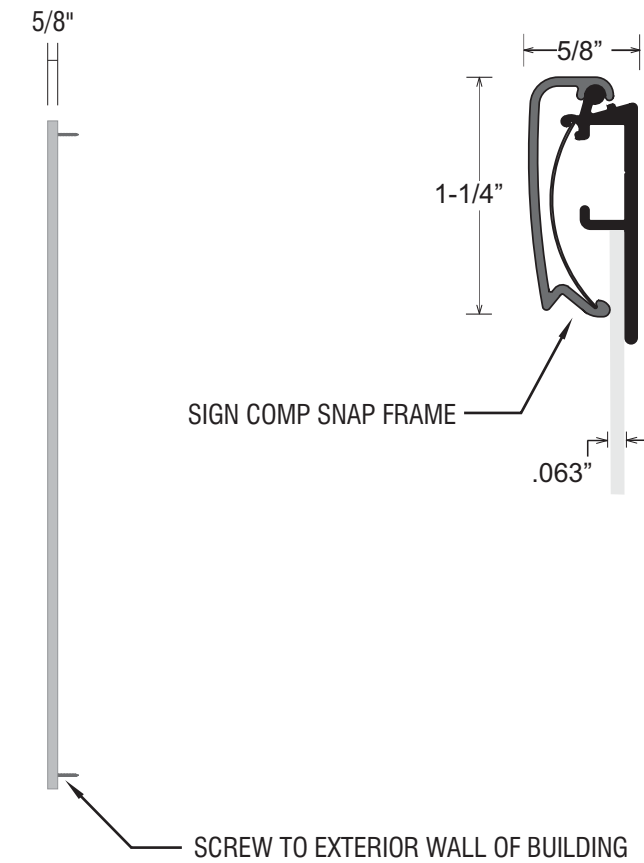

ELEVATION:
WALK-UP WINDOW
SCALE: 1/8"=1'-0"
(UNLESS OTHERWISE DIRECTED)
2" INSET FROM MULLION
2" ABOVE STONE CAP
6" BETWEEN MENUS

SCOPE OF WORK: PROVIDE (2) ILLUMINATED MENU SIGNS V5 - WALL-MOUNTED



89975 Prairie Rd.
Eugene, OR 97402
541.485.5546 | esasigns.com

SHOP DRAWING #:
37040F

CLIENT:
Dutch Bros - CA3205
Hwy 99 & Archer Ave.
Gridley, CA 95948

DATE OF SHOP DRAWING:
11/28/23

PROD. DETAILS: CH

LEAD DESIGN: CH

SALES: NJ

REVISIONS:

COLOR CODE



DIGITAL PRINT



POWDER COATED
DB CUSTOM DARK BLUE

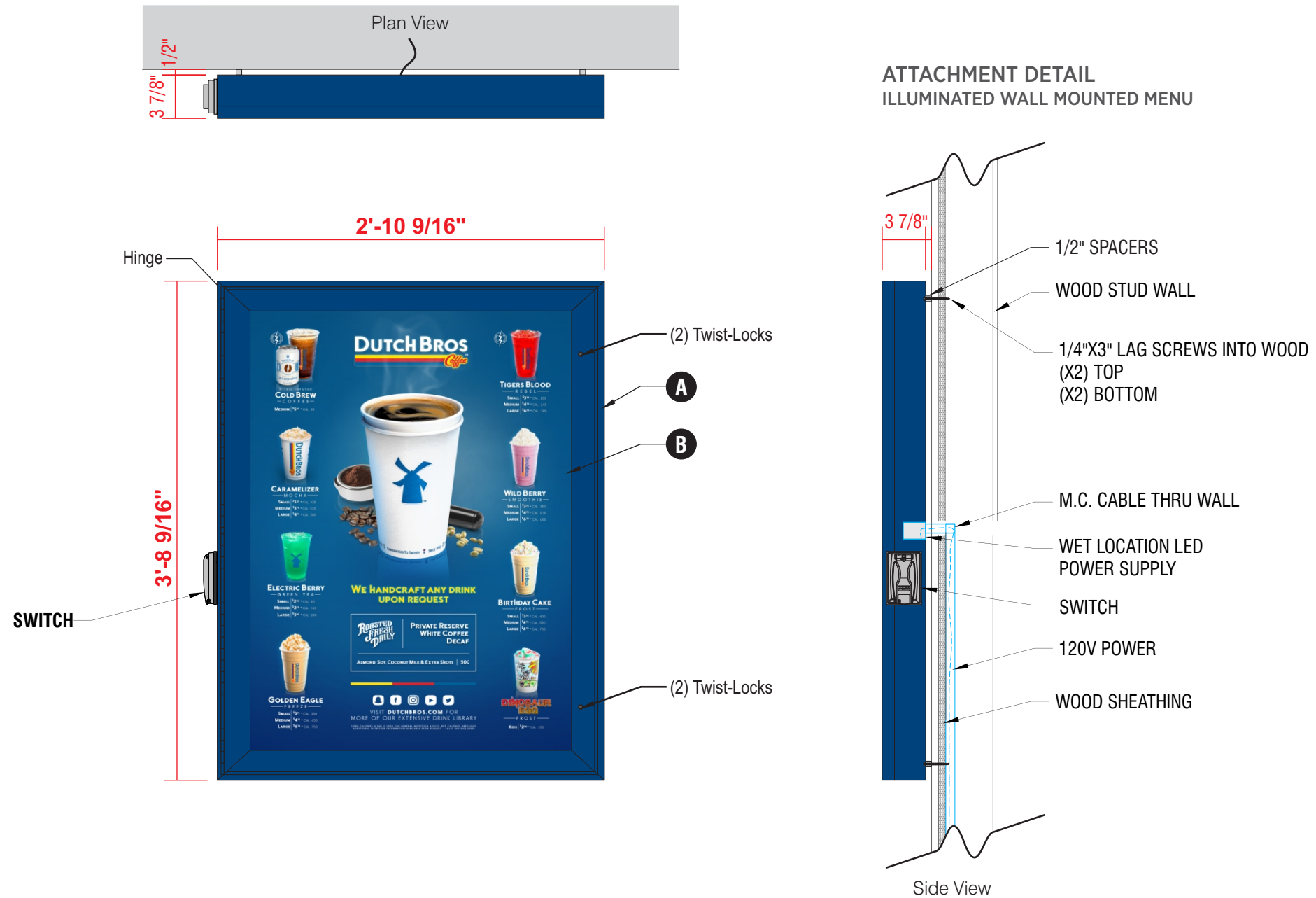

- A** WALL-MOUNTED, BACKLIT MENU SIGN
 - PRINTED MENU PANEL NOT INCLUDED
 - LED OUTDOOR LIGHT BOX
 - LOCKABLE HINGED DOOR
 - ALUMINUM CONSTRUCTION
- B** PRINTED LIGHT GUIDE PANEL
 - AS SEPARATE ORDER

SCOPE OF WORK: PROVIDE (4) S/F ILLUMINATED MENU SIGNS V5 - PLATE-MOUNTED



89975 Prairie Rd.
Eugene, OR 97402
541.485.5546 | esasigns.com

SHOP DRAWING #:
37040G

CLIENT:
Dutch Bros - CA3205
Hwy 99 & Archer Ave.
Gridley, CA 95948

DATE OF SHOP DRAWING:
11/28/23



PROD. DETAILS: CH

LEAD DESIGN: CH

SALES: NJ

REVISIONS:

COLOR CODE

-  DIGITAL PRINT
-  POWDER COATED DB DARK BLUE

SCALE: 1"=1'-0"



SIDE VIEW

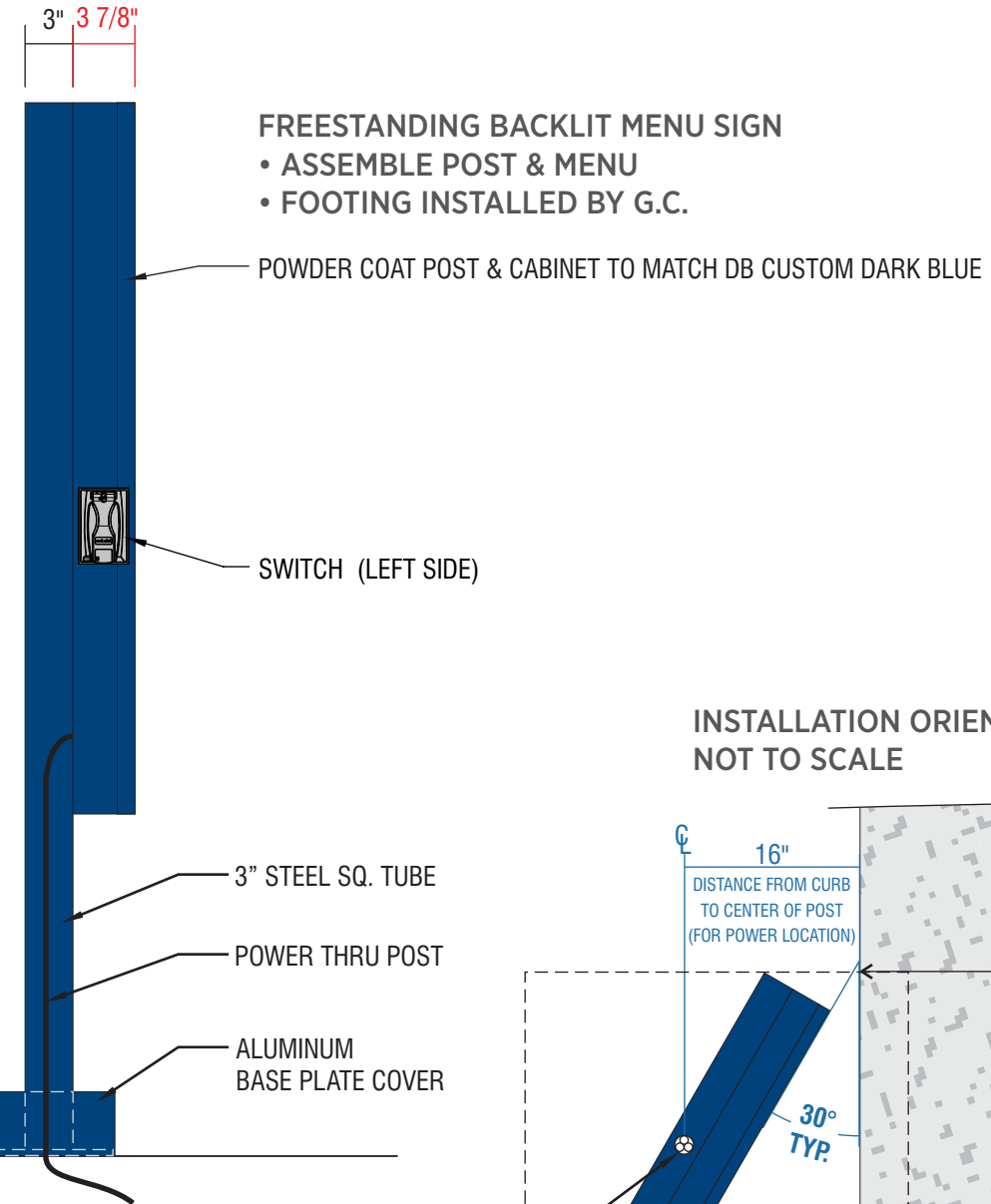

INSTALLATION ORIENTATION DETAIL
NOT TO SCALE

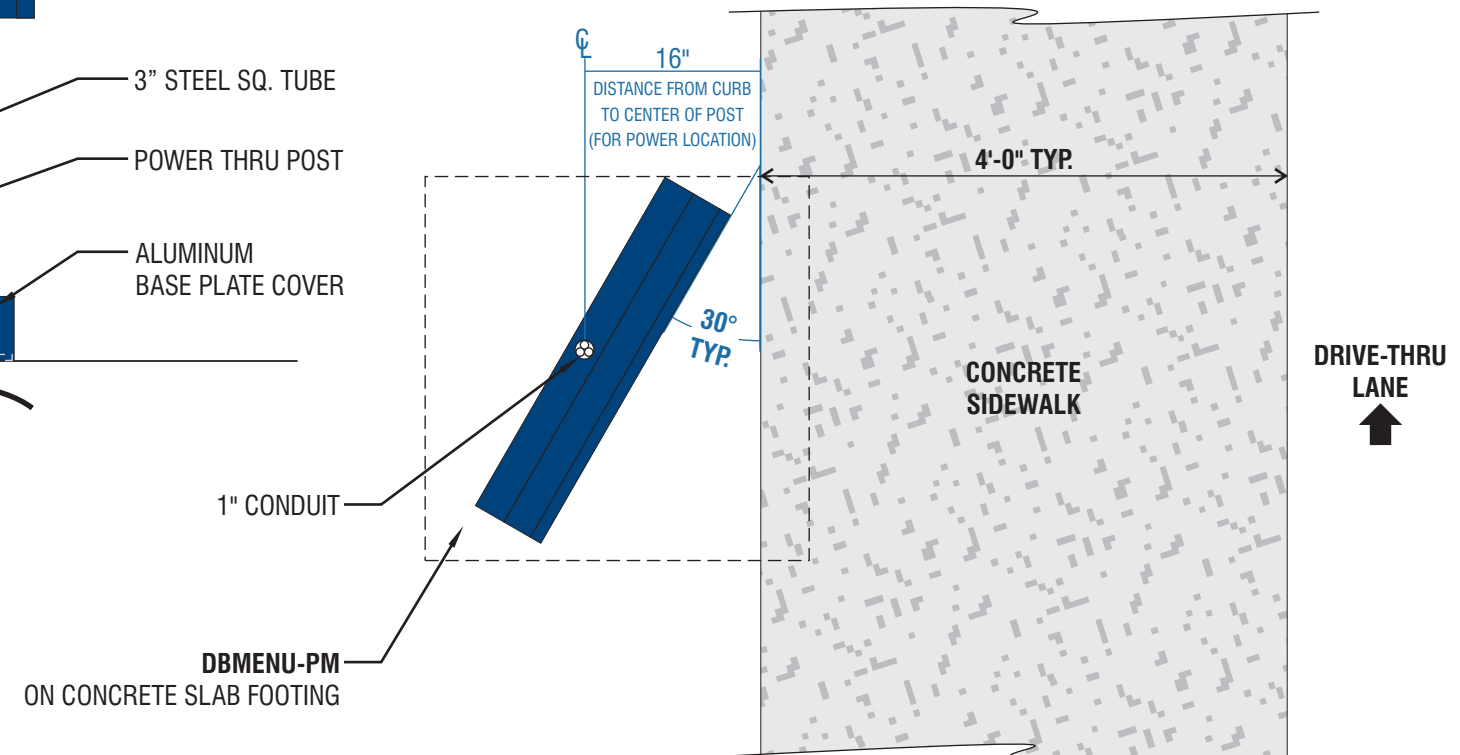



89975 Prairie Rd.
Eugene, OR 97402
541.485.5546 | esasigns.com

SHOP DRAWING #:
37040G

CLIENT:
Dutch Bros - CA3205
Hwy 99 & Archer Ave.
Gridley, CA 95948

DATE OF SHOP DRAWING:
11/28/23

PROD. DETAILS: CH

LEAD DESIGN: CH

SALES: NJ

REVISIONS:

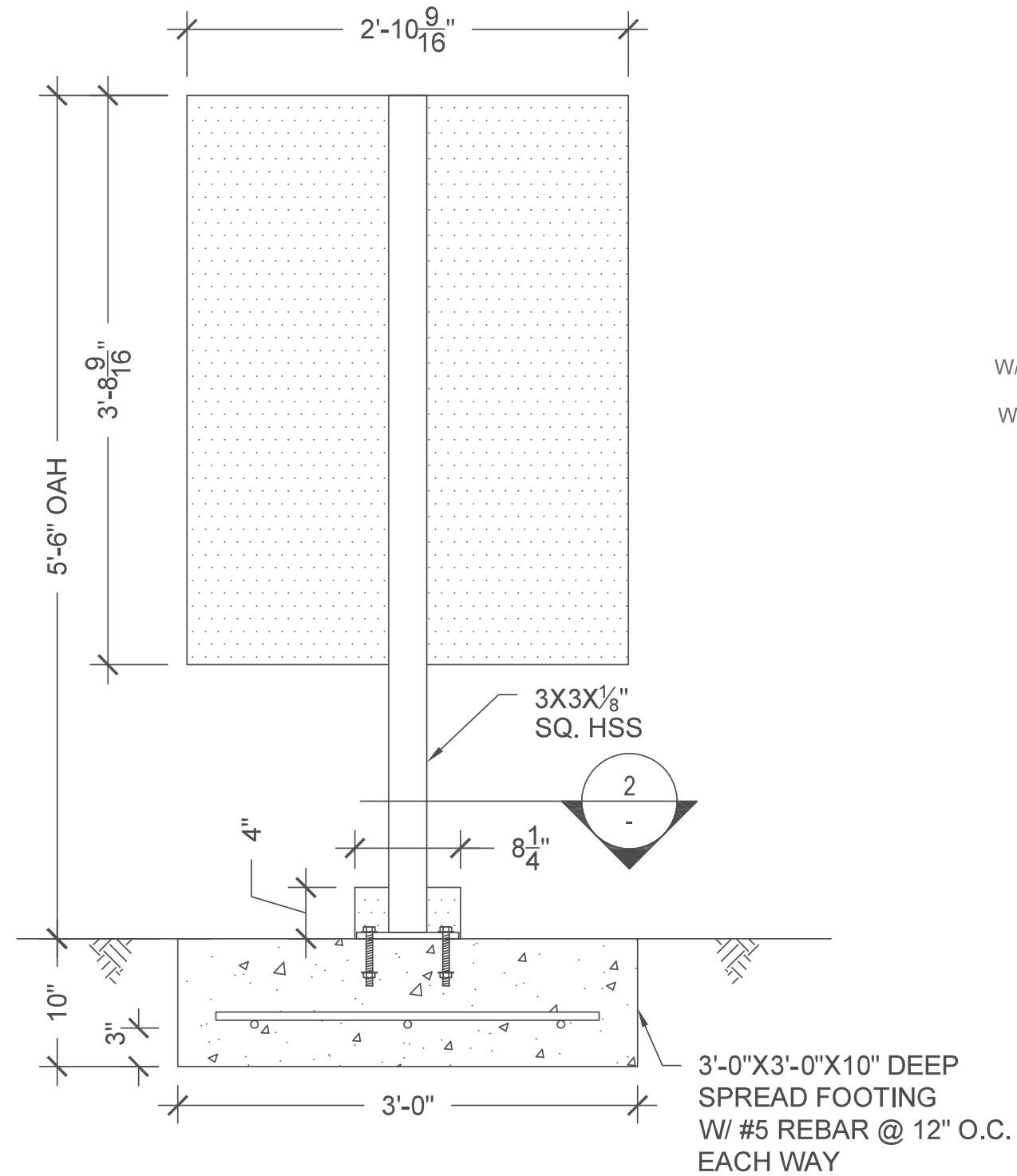

ELEVATION
SCALE: 1"=1'-0"

8"x8"x¹/₂" STEEL PLATE
W/ (4) ¹/₂" Ø THREADED ANCHOR RODS
MIN. EMBED.=4" INTO CONCRETE
W/NUT/WASHER/NUT @ EMBED. END

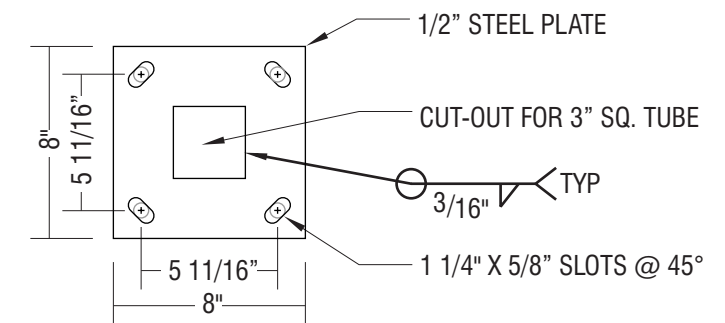

MOUNTING PLATE
SCALE: 1 1/2"=1'-0"

SCOPE OF WORK: MANUFACTURE & INSTALL (1) D/F NON-ILLUMINATED 'DRIVE THRU' SIGN



89975 Prairie Rd.
Eugene, OR 97402
541.485.5546 | esasigns.com

SHOP DRAWING #:
37040H

CLIENT:
Dutch Bros - CA3205
Hwy 99 & Archer Ave.
Gridley, CA 95948

DATE OF SHOP DRAWING:
11/28/23

PROD. DETAILS: CH

LEAD DESIGN: CH

SALES: NJ

REVISIONS:

COLOR CODE

DB CUSTOM DARK BLUE

WHITE

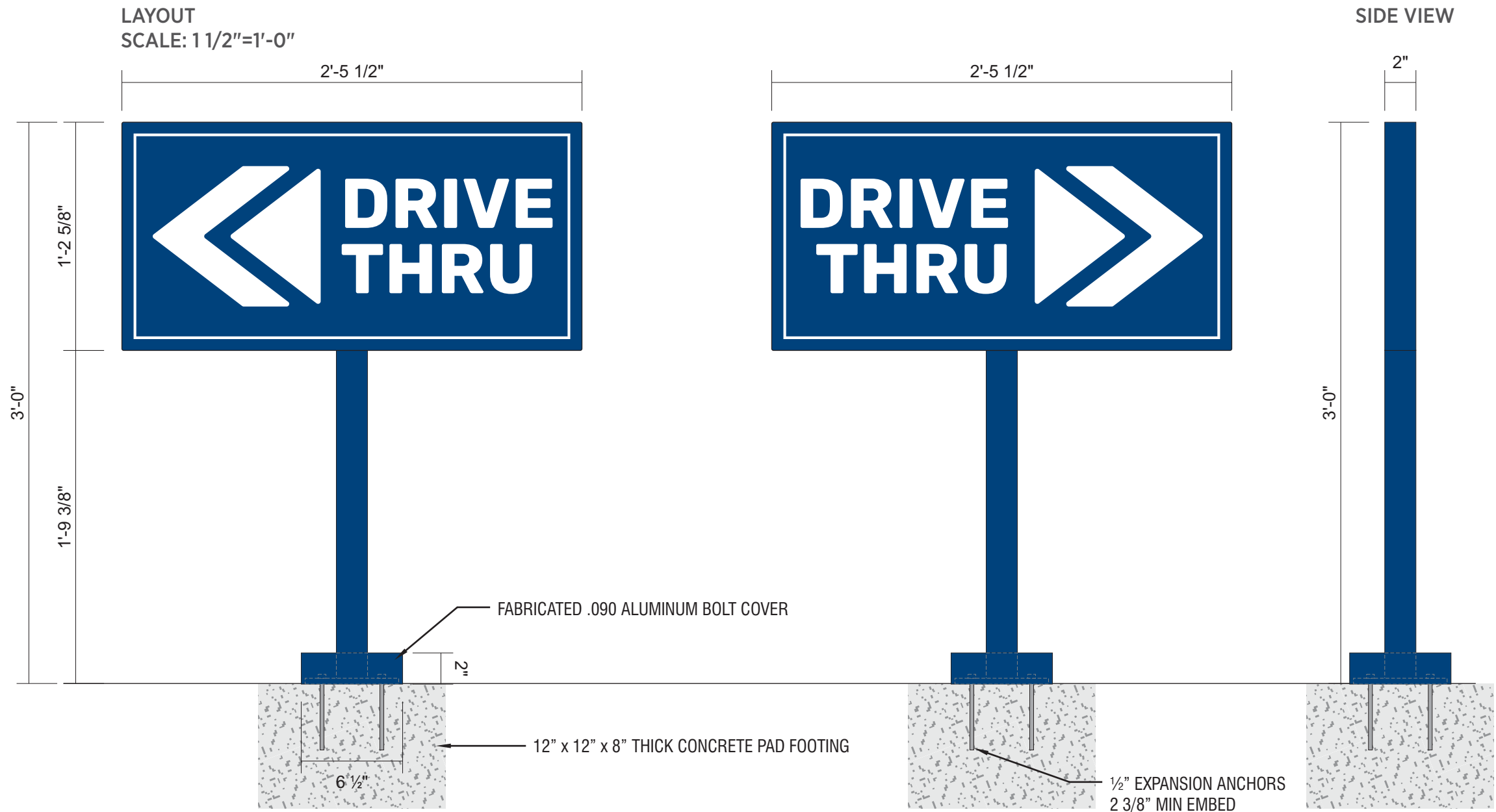

DIAMOND GRADE REFLECTIVE WHITE VINYL WITH DIGITALLY PRINTED BACKGROUND TO MATCH DB CUSTOM DARK BLUE
(SPECIAL PRODUCTION NOTE: GRAPHICS TO BE INSET FROM EDGE 1/8").

2" X 2" SQUARE TUBE ALUMINUM FRAME & POST WITH ALUMINUM FACES & 1/4" X 6" X 6" PLATE

FABRICATED .090 ALUMINUM BOLT COVER

PAINT DB CUSTOM DARK BLUE

INSTALL PLATE-MOUNT SIGN WITH 1/2" EXPANSION ANCHORS

PAD FOOTING INSTALLED BY GC

SCOPE OF WORK: MANUFACTURE & INSTALL (1) D/F NON-ILLUMINATED EXIT SIGN



89975 Prairie Rd.
Eugene, OR 97402
541.485.5546 | esasigns.com

SHOP DRAWING #:
370401

CLIENT:
Dutch Bros - CA3205
Hwy 99 & Archer Ave.
Gridley, CA 95948

DATE OF SHOP DRAWING:
11/28/23

PROD. DETAILS: CH

LEAD DESIGN: CH

SALES: NJ

REVISIONS:

COLOR CODE

 DB CUSTOM DARK BLUE

 WHITE

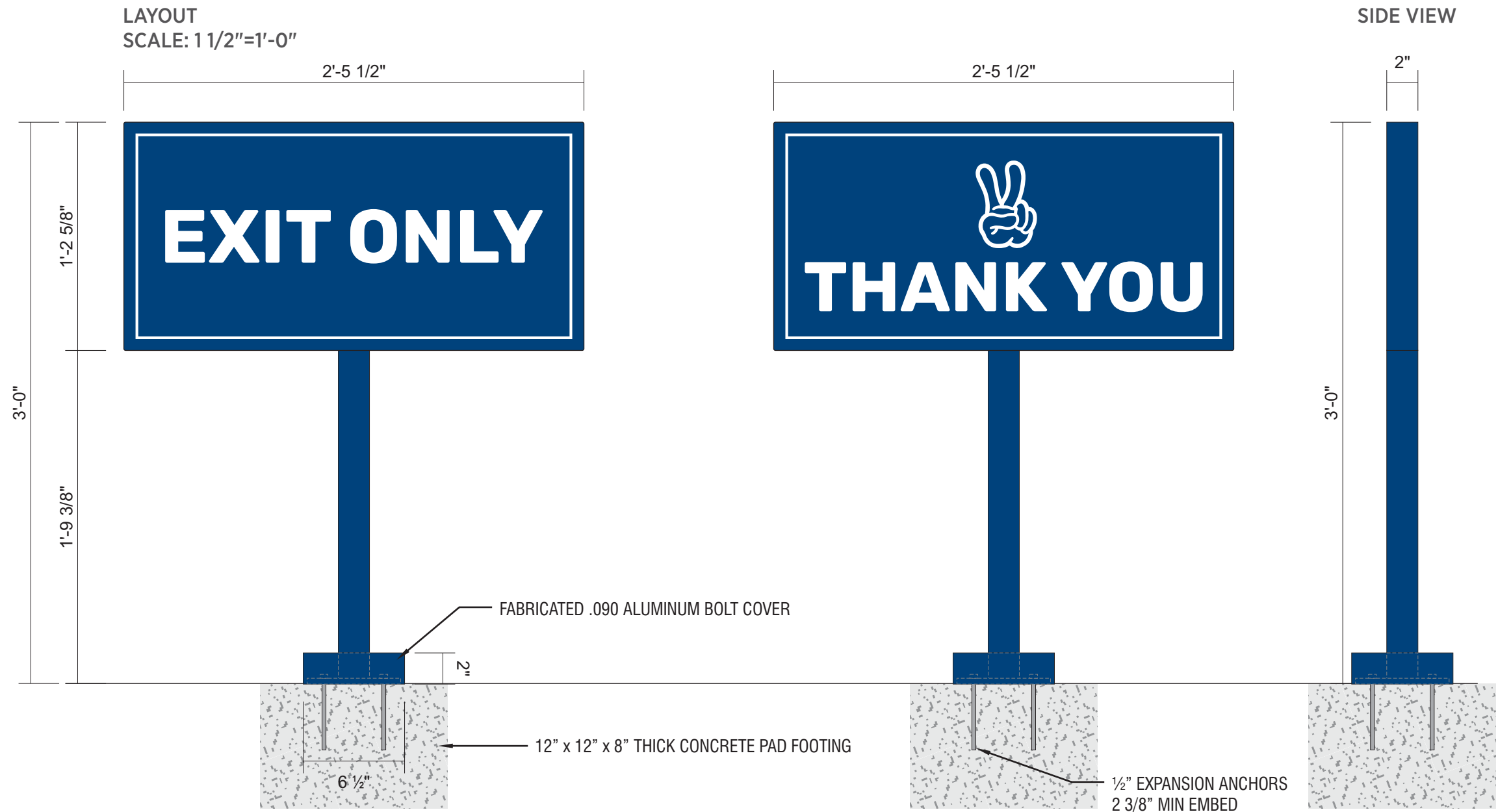

DIAMOND GRADE REFLECTIVE WHITE VINYL WITH DIGITALLY PRINTED BACKGROUND TO MATCH DB CUSTOM DARK BLUE
(SPECIAL PRODUCTION NOTE: GRAPHICS TO BE INSET FROM EDGE 1/8").

2" X 2" SQUARE TUBE ALUMINUM FRAME & POST WITH ALUMINUM FACES & 1/4" X 6" X 6" PLATE

FABRICATED .090 ALUMINUM BOLT COVER

PAINT DB CUSTOM DARK BLUE

INSTALL PLATE-MOUNT SIGN WITH 1/2" EXPANSION ANCHORS

PAD FOOTING INSTALLED BY GC



89975 Prairie Rd.
Eugene, OR 97402
541.485.5546 | esasigns.com

SHOP DRAWING #:
37040J

CLIENT:
Dutch Bros - CA3205
Hwy 99 & Archer Ave.
Gridley, CA 95948

DATE OF SHOP DRAWING:
11/28/23

PROD. DETAILS: CH

LEAD DESIGN: CH

SALES: NJ

REVISIONS:

COLOR CODE

 REFLECTIVE WHITE PSV

 DB CUSTOM DARK BLUE

CLEARANCE SIGN
SCALE: 3"=1'-0"



3MM ACM SIGN PANEL PAINTED DB CUSTOM DARK BLUE.
WHITE REFLECTIVE VINYL COPY & BORDER (NUMBERS SHIPPED LOOSE & FIELD APPLIED).
MOUNT DIRECTLY TO ALUMINUM AWNING DRIVE-THRU ENTRANCE SIDE
WITH EXTERIOR GRADE 3M VHB TAPE.

ELEVATION
SCALE: 1/2"=1'-0"

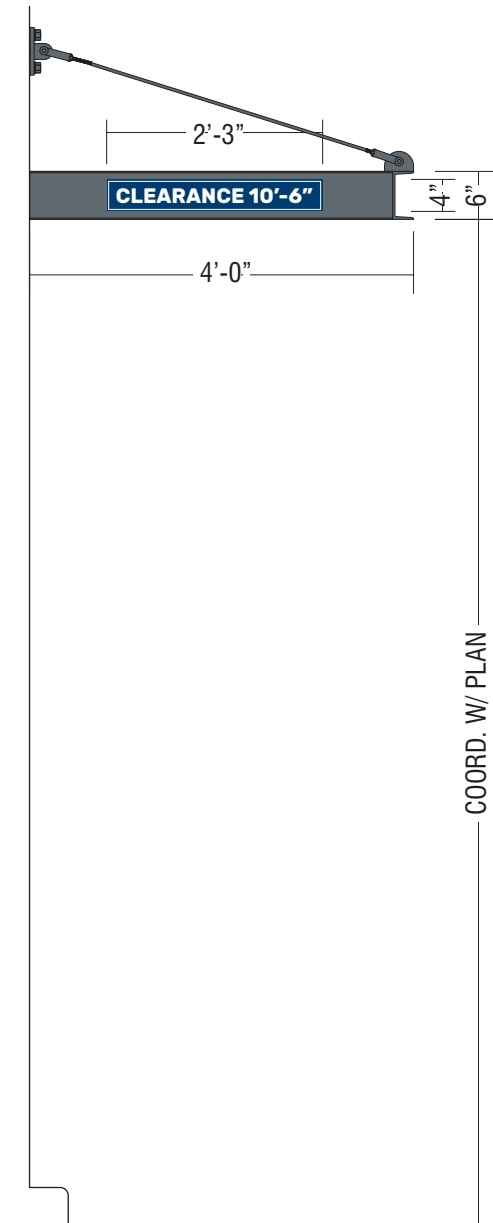

COORD. W/ PLAN

SCOPE OF WORK: MANUFACTURE & INSTALL (1) SET OF BUILDING ADDRESS NUMBERS



89975 Prairie Rd.
Eugene, OR 97402
541.485.5546 | esasigns.com

SHOP DRAWING #:
37040K

CLIENT:
Dutch Bros - CA3205
Hwy 99 & Archer Ave.
Gridley, CA 95948

DATE OF SHOP DRAWING:
11/28/23

PROD. DETAILS: CH

LEAD DESIGN: CH

SALES: NJ

REVISIONS:

COLOR CODE

SATIN WHITE PAINT
 REFLECTIVE WHITE VINYL

BUILDING ADDRESS
SCALE: 1 1/2"=1'-0"

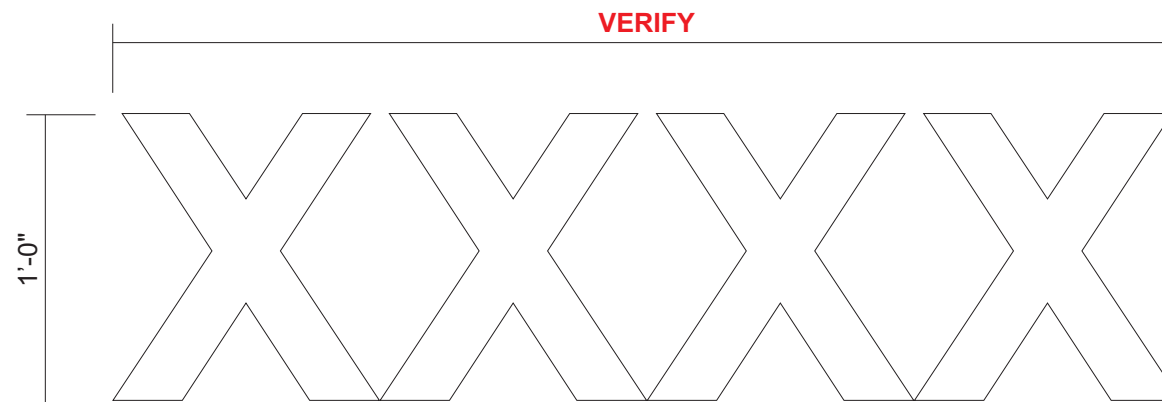

ADDRESS NUMBERS:
FONT: ARIAL BOLD
MATERIAL: 1/4" THICK ALUMINUM
COLOR: PAINTED SATIN WHITE WITH 3M REFLECTIVE WHITE VINYL, INSET 1/8"
INSTALLATION: STUD MOUNTED FLUSH TO BUILDING

SIDE DETAIL
FULL SCALE

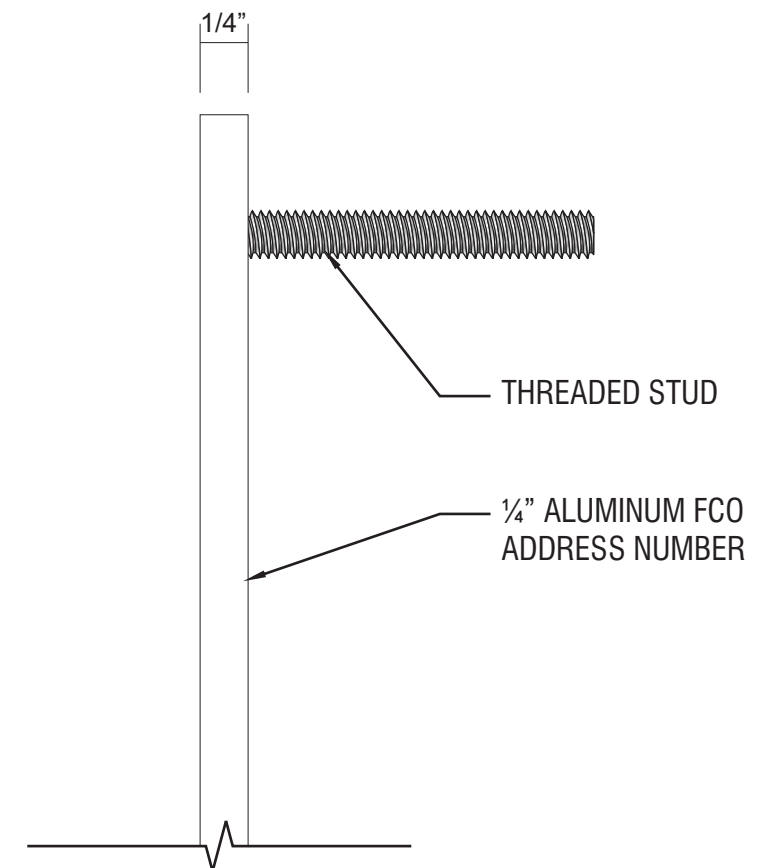

Planning Commission Item #3
Staff Report

Date: April 17, 2024
To: Chair and Planning Commissioners
From: Donna Decker, Planning Department
Subject: Housing Element Update 2022-2030

X	Regular
	Special
	Closed
	Emergency

Recommendation

Planning Commission to review the existing Housing Element, discuss, and hear public testimony.

Summary

The State of California, Department of Housing and Community Development (HCD) has outlined a process by which local governments need to update housing elements to maintain compliance with the legislative statutes. The planning period for the City of Gridley is eight years coinciding with the Butte County Association of Government’s 6th cycle planning period.

The purpose of the public review is to gain feedback from the community and the decision making bodies of the City to revise, and ultimately submit a plan that provides measurable implementation strategies supporting housing development.

Discussion

The Housing Element is a required section of the General Plan. The City of Gridley adopted the 2030 General Plan in 2010 followed by adoption of the 2009-2014, and the 2014-2022 Housing Element(s). The General Plan had prepared an Environmental Impact Report (EIR) to consider CEQA impacts. There are no changed circumstances with the 6th cycle update, therefore no additional environmental review has been done.

Each planning cycle changes the allocation of required available land for development. This is due to a changing population, the changing economic and demographic information of that population, and the forecasting of where the increases may occur. The City of Gridley receives the regional housing needs allocation numbers (RHNA) from the Butte County Association of Governments (BCAG) who in turn receive the allocation from the State of California Housing and Community Development Department. The quantity of housing needed is determined also by income affordability levels and to insure that housing can be provided for very low, low, moderate, and above moderate income levels. Any unmet need from the previous cycle is also required to be met. The Housing Element analysis has confirmed there is an adequate land inventory available to meet the previous RHNA allocation.

The review and update to the Housing Element consists of:

- Updating census data correctly reflecting population demographics;
- Employment characteristics;
- Available housing and condition assessment;
- Housing affordability, tenure, and age;
- Special Housing needs;
- Energy efficiency and conservation;
- Housing needs projections, land inventory, and housing allocation;
- Constraints inhibiting the development of adequate housing related to government and non-government restrictions;
- An evaluation of the 2014-2022 Housing Element implementation strategies, and,
- The development of a new Housing Plan.

The resulting analysis for the existing Housing Element indicated the City of Gridley had an adequate inventory of developable land to meet the 5th planning cycle housing needs. The analysis will review what additional land if any, would be needed to meet the 6th planning cycle.

Public Notice

A notice was advertised in the Gridley Herald, posted at City Hall, and available at the Administration Counter, and placed on the City website. At the time this report was prepared, no comments had been received.

Environmental Review

The City of Gridley has determined in accordance with Section 15162 of the CEQA Guidelines, that the 6th cycle planning update of the Housing Element, 2022-2030, constituting a text amendment to the 2030 General Plan, does not involve new significant effects beyond those analyzed for the 2030 General Plan Final Environmental Impact Report, therefore no additional CEQA review is required and action may be taken on this item.

Attachments

Housing Element 2014-2022



HOUSING

City of Gridley

2014-2022 Housing Element



DECEMBER, 2014

ACKNOWLEDGEMENTS

CITY OF GRIDLEY 2014—2022 Housing Element

Gridley City Council

Jeff Draper, Mayor
Pedro Mota, Mayor Pro Tem
Jerry Ann Fichter
Frank Hall
Owen Stiles

Gridley Planning Commission

Shirley O'Brien, Chair
Robert Thomas, Vice Chair
Herman Sunderman

&

Rob Hickey, City Administrator

With acknowledgement to the contributions of the City of Gridley
Planning Consultant, Donna Decker, DES

December 1, 2014

TABLE OF CONTENTS

Chapter 1: INTRODUCTION	
Goals and Policies	4
Policy and Regulatory Context	5
Data Sources and Methodology	7
Public Involvement	7
Chapter 2: COMMUNITY PROFILE	
Population	9
Employment	14
Housing	18
Housing Costs and Affordability	23
Special Housing Needs	28
Chapter 3: OPPORTUNITIES FOR ENERGY CONSERVATION	
Energy Efficiency For New Construction	39
Greenhouse Gas Emissions Reductions	39
Gridley 2030 General Plan	41
Chapter 4: HOUSING NEEDS	
Regional Housing Needs Allocation	42
Inventory of Assisted Housing Units	44
Preservation Options	46
Chapter 5: HOUSING RESOURCES	
Land Inventory	49
Funding and Administrative Resources	56
Chapter 6: CONSTRAINTS TO HOUSING AVAILABILITY AND AFFORDABILITY	
Government Constraints	64
Market Constraints	82
Chapter 7: PROGRAM EVALUATION	
2009-2014 Housing Plan Review and Revise	85
Housing Production	86
Chapter 8: HOUSING PLAN	
Goals, Policies, and Implementation Strategies	104

LIST OF TABLES AND FIGURES

TABLES

Table 1	Population Trends for Gridley	9
Table 2	Population Trends Countywide-Butte County	10
Table 3	Population by Age, City of Gridley	11
Table 4	Population by Age, Butte County	12
Table 5	Population by Race, City of Gridley	13
Table 6	Population by Race, Butte County	13
Table 7	Employment by Industry, City of Gridley	14
Table 8	Largest Employers, City of Gridley	15
Table 9	Annual Average Employment, City of Gridley	16
Table 10	Education Level	17
Table 11	Number of Households	18
Table 12	Households by Tenure and Age	19
Table 13	City/County Population & Housing Estimates-Units	20
Table 14	Vacancy Rates in Butte County	21
Table 15	Housing Vacancy	21
Table 16	Housing Unit by Year Built	22
Table 17	State Income Limits for 2014 (Butte County)	24
Table 18	Maximum Affordable Monthly Housing Cost	24
Table 19	Rental Costs	25
Table 20	Recently Sold Homes	25
Table 21	Households by Income Category	26
Table 22	Household Type and Cost Burden	27
Table 23	Overcrowded Households	28
Table 24	Developmentally Disabled	29
Table 25	Disabled Persons by Employment Status	30
Table 26	Disability by Type and Age	31
Table 27	Large Households and Housing Units	33
Table 28	Senior Population by Gender	34
Table 29	Senior Household by Tenure	34
Table 30	Homeless Population	35
Table 31	Consumer Spending Categories	37
Table 32	Regional Housing Needs Allocation	43
Table 33	Unaccommodated Housing Need	43
Table 34	RHNA Allocation Total	44
Table 35	Assisted Housing Inventory	45
Table 36	Rent Subsidies Required to Preserve At-Risk Housing	47
Table 37	Units Under Construction or Approved	50
Table 38	Examples of Affordable Housing Projects	52
Table 39	Residential land Inventory related to EL/VL/L	55
Table 40	Residential land Inventory related to M/AM	56
Table 41	Federal/State Financial Resources	61
Table 42	Residential Densities	66
Table 43	Parking Requirements	67
Table 44	Permitted Residential Land Uses by Zoning District	68

Table 45	Comparison of Planning Fees	75
Table 46	Development Impact Fees	76
Table 47	Unaccommodated Housing Need 2009-2014	87
Table 48	RHNA Allocation Total 2014-2022	87
Table 49	Housing Element Review and Revise	88
Table 50	Housing Plan	104
Table 51	Summary of Quantified Objectives – 2014-2022	116

FIGURES

Figure 1	Population Growth Trends in Butte County	10
Figure 2	Household Income	17
Figure 3	Age of Housing by Tenure	23
Figure 4	Inventory of Developable Land	56

Chapter 1: INTRODUCTION

The State of California recognizes that an adequate supply of affordable housing for all income levels is a fundamental need for all communities. To achieve that goal, it is critical that all local governments share in the responsibility of implementing solutions to address local and regional housing needs. To that end, all California local governments are required to prepare a housing element (or housing chapter of the General Plan) that specifies how the community will plan for its housing needs. The detailed statutory requirements for preparing a housing element are codified in the California Government Code (sections 65580–65589). As stated therein, the housing element must contain an identification and analysis of its existing and projected housing needs; an analysis of the various governmental and non-governmental constraints to meeting that need; and a series of goals, policies, and scheduled programs to further the development, improvement, and preservation of housing.

The Housing Element of the 2030 General Plan is designed to provide the City of Gridley with a coordinated and comprehensive strategy promoting the production of safe, decent, and affordable housing for all segments and income levels of the community. Housing is an established priority of both the State of California and the City of Gridley, as expressed in Government Code Section 65580:

“The availability of housing is of vital statewide importance, and the early attainment of decent housing and a suitable living environment for every Californian, including farm workers, is a priority of the highest order.”

The Housing Element provides an assessment of both current and future housing needs and the constraints in meeting these needs resulting in the development of implementation strategies. The Housing Element has an eight year planning period (2014-2022) which differs from the other elements of the General Plan.

Goals and policies

The goals and policies provide a framework for the development of an implementation strategy to meet Gridley’s housing needs. The key housing strategies identified in the General Plan are:

- ✓ Provide local housing options that accommodate our different households’ needs and preferences.
- ✓ Support affordable housing for residents and help keep the younger population in Gridley;
- ✓ Maintain high-quality housing for our senior population.

Gridley’s challenge is to accommodate housing suitable for a diversity of household types and incomes and in sufficient amounts to provide for its share of regional housing needs. State law provides guidance for meeting both the amount and variety of housing by providing regional housing allocations that are then distributed to the local municipalities that will need to be met within the Housing Element’s planning period. This Housing Element addresses housing needs during an eight year planning period from 2014 to 2022 for which the Regional Housing Needs Assessment was prepared by Butte County Association of Governments (BCAG).

The housing plan will continue to develop programs that focus on effective strategies:

- ✓ Maintain housing safety and quality;
- ✓ Match housing supply with need;
- ✓ Assist in the provision of affordable housing;
- ✓ Ensure adequate land is available and zoned appropriately for housing;
- ✓ Remove government constraints to housing development; and,
- ✓ Promote fair and equal housing opportunities.

To achieve these priorities, the Housing Element is organized into the following components:

- ✓ **Introduction** provides an overview of the Element’s purpose, content, and policy and regulatory context.
- ✓ **Community Profile** provides analysis of the city’s demographics, housing characteristics, and existing and future housing needs.
- ✓ **Opportunities for Energy Conservation** describe opportunities for energy conservation, including state requirements for energy efficiency for new construction and greenhouse gas emissions reduction targets.
- ✓ **Housing Needs** assesses projected housing needs, including analysis of affordable housing at-risk of conversion to market rate.
- ✓ **Housing Resources** identifies available resources to meet housing needs for all income levels, including vacant or underutilized land for new construction or redevelopment, as well as financial and administrative resources available for housing.
- ✓ **Constraints to Housing Availability and Affordability** provides an analysis of constraints to housing production and maintenance, such as market, governmental, and environmental factors affecting the city’s ability to meet identified housing needs.
- ✓ **Program Evaluation** of 2009-2014 Housing Plan reviewing past accomplishments and evaluates existing strategies that should be continued, modified, added, or deleted.
- ✓ **Housing Plan** identifies the overall housing goals, policies, and implementation strategies to address the City’s identified housing needs for the 2014-2022 planning period.

Policy and regulatory context

The Housing Element addresses a broad range of issues related to housing, including affordability, accessibility, mobility, energy conservation, infill and revitalization, balanced growth, and regulatory issues. The Housing Element defines the City’s housing strategy and incorporates policies and implementing actions from other local plans to ensure consistent local management of land use change. Related planning documents include the Butte County Association of Governments (BCAG) 2012 Regional Housing Needs Plan reflecting an eight year planning period from January, 2014 to June, 2022 and the City of Gridley 2030 General Plan.

State housing policy and strategy

In 1980, the State of California amended the Government Code by adding Article 10.6, dealing with the preparation of housing elements of local general plans. By enacting this statute, the legislature found that:

"the availability of housing is of vital statewide importance, and the early attainment of decent housing and a suitable living environment for every California family is a priority of the highest order. The early attainment of this goal requires the cooperative participation of government and the private sector in an effort to expand housing opportunities and accommodate the housing needs of Californians of all economic levels. Local and state governments have a responsibility to use the powers vested in them to facilitate the improvement and development of housing to make adequate provision for the housing needs of all economic segments of the community..."

This Housing Element is drafted in compliance with state law, which requires that housing elements, at a minimum, contain (Government Code Section 65583):

- ✓ An assessment of housing needs and an inventory of resources and constraints relevant to meeting these needs;
- ✓ A statement of the community's goals, quantified objectives, and policies relative to the maintenance, preservation, improvement, and development of housing;
- ✓ An inventory of sites capable of accommodating development of housing for a range of income types to meet the City's share of the regional housing need; and,
- ✓ A program that sets forth actions to implement the policies and achieve the goals and objectives of the Housing Element.

In 1999, the State issued the California Statewide Housing Plan Update. Many of the issues described in this Plan are still quite relevant and important to consider in the context of local housing plans. The City carefully considered each of these key issues as a part of the 2030 General Plan and this Housing Element update. Key issues from the Statewide Housing Plan include:

- ✓ Much higher levels of housing construction are needed to adequately house the State's population;
- ✓ High housing cost burdens are increasingly an issue for both owners and renters. The combination of upward price pressure in the housing markets and relatively tight urban housing markets has led to increasing cost burdens, particularly for low-income renter residents;
- ✓ In some portions of the State, the level of overcrowding has dramatically increased;
- ✓ A substantial portion of affordable rental housing developments statewide are "at-risk" of conversion to market rate use;
- ✓ Significant numbers of temporary agricultural workers migrate throughout the state unable to find affordable housing; and,
- ✓ Homeless individuals and households face significant difficulties in obtaining shelter.

Regional housing needs allocation (RHNA)

A critical measure of compliance with state housing law is the ability of a jurisdiction to accommodate its share of regional housing need as determined by a Regional Housing Needs Assessment (RHNA) (sometimes called regional housing needs allocation). The Butte County Association of Governments (BCAG) is charged with distributing the local share of the regional housing needs among the cities and unincorporated areas of the county.

The Regional Housing Needs Plan (RHNP) was issued by BCAG in 2012. The purpose of the RHNP is to allocate to the cities and county their “fair share” of Butte County’s projected housing need by household income group over the 8 year (2014-2022) planning period covered by the plan. Information is provided in Chapter 4, “Housing Needs”, describing the numerical regional housing allocation assigned to the City of Gridley and Chapter 5, “Housing Resources” outlines land suitable to provide future housing.

General plan consistency

The Housing Element is one of the required components of the General Plan. The 2030 General Plan, updated in 2010, provides the overarching policy guidance for development and conservation throughout the Plan Area. The General Plan consists of the nine (9) elements addressing the planning issues required by the state.

The Housing Element’s goals, policies, and implementation strategies are consistent with the General Plan. Furthermore, the Housing Element provides an inventory of available land that can be developed for housing meeting the full range of household incomes within the City’s existing incorporated boundary.

Data sources and methodology

Various sources of information contribute to the Housing Element. Data from the 2000 and 2010 Census and American Community Survey (ACS) provides the basis for population and household characteristics. Several additional data sources were used to supplement Census Bureau data including, but not limited to:

- ✓ Population and demographic estimates and projections by the Butte County Association of Governments and the California Department of Finance;
- ✓ Housing conditions and market information, such as home sales, rents, and vacancies, are provided using the Department of Housing and Urban Development’s Comprehensive Housing Affordability Strategy (CHAS) data and is updated with City surveys and property tax assessor’s files;
- ✓ Public and nonprofit agencies were consulted for data on special needs groups, availability of services, and gaps in the service delivery system; and,
- ✓ Lending patterns for home purchase and home improvement loans are provided using the Home Mortgage Disclosure Act (HMDA) database.

Public involvement

State law requires cities and counties to make a “diligent effort” to achieve participation by all segments of the community in preparing a housing element (Section 65583[c] [6] of the California

Government Code). The diligent effort required by State law translates into local jurisdictions doing more than issue the customary public notices and conduct standard public hearings prior to adopting a housing element. State law requires cities and counties to take active steps to inform, involve, and solicit input from the public, particularly low-income and minority households that might otherwise not participate in the process.

To meet the requirements of State law the city encouraged public participation from all segments of the community by conducting public meetings, advertisement in the local newspaper, *The Gridley Herald*, of the status of the update, and an invitation to comment. The city engaged the community by:

- ✓ Housing Element “kick-off” meeting at the City Council January 6, 2014 public hearing and workshop;
- ✓ Public workshops with the Planning Commission on February 4, 2014, March 4, 2014, March 18, 2014, April 15, 2014, May 20, 2014, June 17, 2014, and August 18, 2014. The City continues to maintain the item on the agenda for continued public discussion;
- ✓ August 5, 2014 community outreach with flyers and questionnaires at the Farmer’s Market;
- ✓ Comprehensive “Housing Survey” mail inserts to all households in the utility billing. The City has received an approximate 10% return of the surveys with comments related to areas of concern;
- ✓ Web site informational posting and the ability to provide public input through the website;
- ✓ Provided an article for *The Gridley Herald* describing the Housing Element update process inviting any interested individuals to attend Planning Commission meetings, City Council meetings, contact staff or send comments related to the existing housing and what the community may wish to improve;
- ✓ Direct door to door contact with questions related to process, inquiry, and solicited comments from residents while conducting the Housing Condition Survey, and.
- ✓ The City conducted public outreach inviting various community groups and associations for discussion:
 - Community Housing Improvement Program
 - Regional Housing Authority of Sutter and Nevada Counties
 - City of Gridley Senior Housing Program
 - Independent Living Program
 - Gridley Medical Group/Gridley Health Center
 - Sabbath House Women’s Center/Jesus Center
 - Various local church organizations
 - Guardians

The surveys returned indicate a general attitude of pride in the community. Comments expressed concern that the cost of housing continues to increase impacting the ability of younger families from purchasing a home, an aging population is creating an increase in demand of affordable senior housing as well as a need for more services, and ordinances should be passed to require upkeep of homes. Although there are few homes with structural repair issues, the city found approximately 55% of the surveyed homes in which minor aesthetic improvements would create better curb appeal. These comments are reflected again in the community outreach. Comments made relate to utility cost increases over time are impacting affordable homeownership opportunities.

Chapter 2: COMMUNITY PROFILE

The community profile provides important information with which to assess current and future housing needs. This chapter provides community data related to population, age, race, employment, housing availability, housing costs and affordability, and special needs. These characteristics affect the projected housing needed in the community during the next planning period of 2014-2022.

Data in this chapter is derived from a variety of sources and has been compiled to show relationships and major trends. The most recent available data by source was used, and notations are provided within the text and charts to document the source data and source year. Data sources used are:

- US Census data, in varying forms, including the decennial census from 1990, 2000, and 2010;
- Comprehensive Housing Affordability Strategy (CHAS) data, which are based on the most recent census data;
- Housing market information uses realtytrac.com and City of Gridley data;
- American Community Survey (US Census) 2007-2011;
- Department of Finance, State of California Population estimate for 2009-2011(dof.ca.gov/research)
- 2012 Ag Census for related farmworker housing information;
- HUD and/or Continuum of Care for the disabled;
- BCAG projections of Regional Housing Needs Determination, 2012

Population

Future housing needs will be dictated by its changing population, household characteristics, and the condition of existing housing. Factors such as age, race/ethnicity, occupation and income level combine to influence the type of housing needed and the ability to afford housing. The rate of growth of a community is a significant factor.

Gridley, located in Butte County, is a small, rural community. The population has been increasing at a fairly steady rate since 1990, somewhat slowing over the last 3-5 years. Between 2000 and 2010, the City's population increased 21.7%, reaching an estimated population of 6,584 in 2010. More recently growth has continued but slowing at a rate of 0.6% increasing the population to 6,723. Gridley's population is the second fastest growth rate, second to Oroville with a 0.8% annual growth rate.

Table 1
Population Growth Trends for Gridley²

Year	Population	Numerical Change	% Change	Average Annual Growth Rate	
				Number	%
1990	4,631				-
2000	5,408	777	16.7	77.7	1.67
2010	6,584	1,176	21.7	117	2.2
Current¹	6,723	139	2.1	39	0.6

¹ The data for current population is January 1, 2013.

² Source: State of California, Department of Finance, E-4 Population Estimates for Cities, Counties, and the State, 2011-2013 with 2010 Census Benchmark

Gridley appears to be trending towards a reduction in growth percentage based on Table 1 above, from 2.2% annual increase in 2010 to 0.6% annual increase between the years 2010 to 2013. The City of Oroville has experienced an annual growth rate of 0.8%, followed by Gridley and then by Chico. The cities of Biggs and Paradise reflect a continued declining (negative) population from 2000 to 2013.

A comparison of population growth countywide is reflected in **Table 2** below:

COUNTY/CITY	Population 4/1/2000	Population 4/1/2010	Population 4/1/2011	Population 4/1/2012	Population 1/1/2013	Average Annual Change	
						#	%
Gridley	5,408	6,584	6,582	6,545	6,723	39	0.6%
County Total	203,171	220,000	220,465	220,263	221,485	413	0.2%
Biggs	1,793	1,707	1,707	1,689	1,692	-4	-0.2%
Oroville	13,004	15,546	15,512	15,494	15,979	120	0.8%
Paradise	26,408	26,218	26,208	26,027	26,063	-43	-0.2%
Chico	60,516	86,187	86,565	87,106	87,671	412	0.5%
Unincorporated	96,042	83,758	83,891	83,402	83,357	-111	-0.1%

Source: State of California, Department of Finance, E-4 Population Estimates for Cities, Counties, and the State, 2011-2013, with 2010 Census Benchmark. Sacramento, California, May 2013.

Gridley’s population growth continues to increase which may be due to its greater affordability in contrast to Oroville or Chico, located 15 miles and 30 miles, respectively from Gridley.

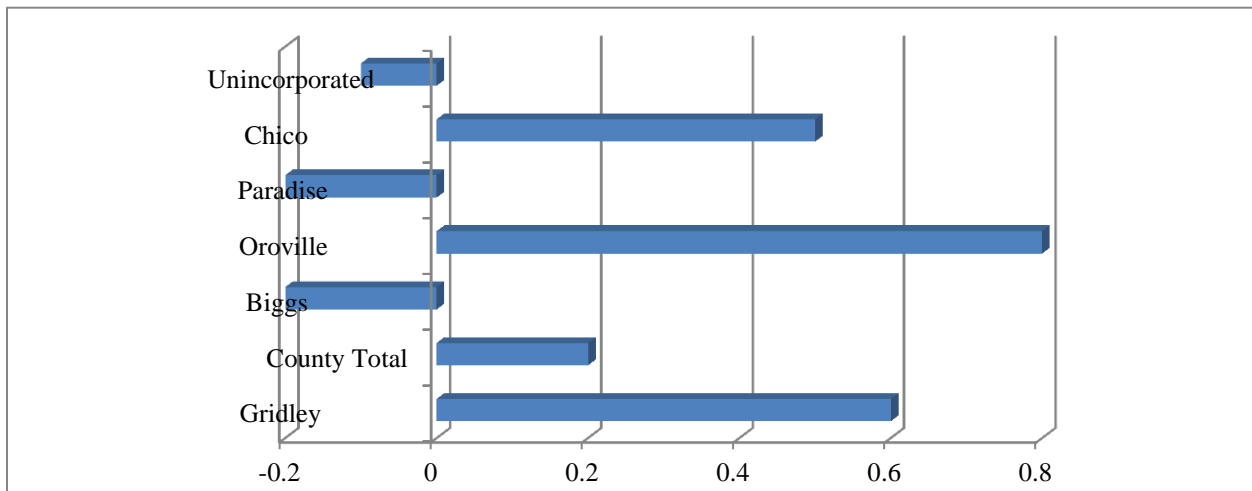

Figure 1: Population Growth Trends in Butte County

Age distribution

Housing needs for communities are determined in part by the age of its residents. There is a direct correlation to housing type and age. Each family has a distinct lifestyle, family type, family size, income level, and housing preference. As the age distribution changes each year those needs will change as well. Evaluating these changes in the population distribution can aid in the determination of the future housing type that is most needed to meet age and lifestyle changes. **Table -3 and Table 4** summarize the age distribution of the population within the city and county for the years 2000 and 2010. Overall, Gridley’s population generally reflects the same distribution as seen in the county; in 2000 the greatest percentage age group was 35-44 years of age. Gridley saw a direction towards a younger population from ages 25-34 years (13.4% of the total population) in 2010 while Butte County reflects an even younger age of its population as 20-24 years (16.1% of the total population). Additionally, Gridley’s population has grown in almost all age groups, with approximately 52% of its population under the age of 34 years, 64% of its population 44 years old or younger, and has a median age of 33.1 years in 2010. These percentages reflect a trend towards an increase in a younger population for the city.

Housing for Gridley’s senior population will continue to be an important area of emphasis for current and future housing planning cycles. Nearly 24% of the total population of Gridley is over the age of 55 years. If most residents currently in their 40’s and 50’s remain in the city over the next 20 years, the senior population would continue to increase both in numbers and proportionally within Gridley.

Another significant age group is youth aged 0 to 19 years. This group saw significant growth during the 10-year period between 2000 and 2010, and accounted for 32 percent of Gridley’s total population in 2010.

**Table 3
Population by Age-City of Gridley**

Age	2000		2010	
	Number	Percent	Number	Percent
Under 5 Years	389	7.2	550	8.4
5 to 9 Years	443	8.2	510	7.7
10 to 14 Years	500	9.3	479	7.3
15 to 19 Years	472	8.8	561	8.5
20 to 24 Years	354	6.6	460	7
25 to 34 Years	657	12.2	881	13.4
35 to 44 Years	707	13.1	800	12.2
45 to 54 Years	553	10.3	800	12.2
55 to 59 Years	236	4.4	325	4.9
60 to 64 Years	214	4	290	4.4
65 to 74 Years	382	7.1	483	7.2
75 to 84 Years	341	6.3	282	4.3
85 Years and over	134	2.5	163	2.5
Greatest % Age	35-44 years		25-34 years	

Table 4
Population by Age-Butte County

Age	2000		2010	
	Number	Percent	Number	Percent
Under 5 Years	11,637	5.7	12,409	5.6
5 to 9 Years	13,409	6.6	12,439	5.7
10 to 14 Years	14,704	7.2	12,911	5.9
15 to 19 Years	17,101	8.4	17,841	8.1
20 to 24 Years	19,648	9.7	22,818	16.1
25 to 34 Years	23,087	11.4	26,681	12.1
35 to 44 Years	27,249	13.4	23,329	10.6
45 to 54 Years	26,809	13.2	28,877	13.1
55 to 59 Years	9,527	4.7	15,265	6.9
60 to 64 Years	7,944	3.9	13,613	7.1
65 to 74 Years	15,207	7.5	17,185	13
75 to 84 Years	12,630	6.2	10,962	5
85 Years and over	4,219	2.1	5,670	2.6
Greatest % Age	35-44 years		20-24 years	

Similar results are found county wide. The population in Butte County depict similar growth and distribution patterns in the census data for 2000. Butte County had a higher growth rate for ages 20-24 years for 2010 which is younger than what Gridley's data reflects. The County distribution shows declines for populations aged 5-9 years, 10-14 years, 35-44 years, and 75-84 years.

Source: 2000, 2010 Census

Population race and ethnic composition

The City of Gridley has greater racial and ethnic diversity than the greater Butte County area and reflects greater integration than many metropolitan urban areas. According to the 2010 Census, approximately 53.3 percent of the city's population was non-white, compared to approximately 24.8 percent non-white in the County as a whole. There are a higher proportion of Hispanic individuals in Gridley of 46 percent versus 14 percent in Butte County (as a whole). The Hispanic population showed a large numerical and therefore percentage increase of 41 percent in the city and 46% in the county. The rising number of persons of Hispanic descent is attributed to the increase in family size and increased immigration to California, in general.

Although the non-Hispanic white population increased between 2000 and 2010, their overall percentage of the population decreased. The African American population also remained static whereas there was a decrease of American Indian and Alaskan Native Americans.

Table 5 and **Table 6** summarize these population characteristics for the City and the County.

Table 5
Population by Race, City of Gridley

Race/Ethnicity	2000		2010		Change	
	Number	Percent	Number	Percent	Number	Percent
White*	2,888	53%	3,074	46.7%	186	6.4%
African American	36	0.7%	36	0%	0	0%
American Indian, Alaska Native	89	1.6%	57	0.86%	-32	36%
Other Race	0	0%	5	0.08%	5	n/a
Two or more Races	179	3.3%	168	2.6%	-11	0.1%
Sub-total Population by Race**	3,321	60.9%	3,584	54.43%	263	7.9%
Persons of Hispanic Descent***	2,129	39.06%	3,000	45.6%	871	41%
Total Population****	5,450	100%	6,584	100%	1,134	20.8%

Table 6
Population by Race, Butte County

Race/Ethnicity	2000		2010		Change	
	Number	Percent	Number	Percent	Number	Percent
White*	162,142	79.80	165,416	75.2%	3,274	2.0%
African American	2,506	1.23	3,133	1%	627	25%
American Indian, Alaska Native	3,367	1.65	3,395	1.49%	28	1%
Other Race	7,296	3.60	9,640	4.39%	2,344	37.4%
Two or more Races	6,483	3.20	7,300	3.3%	817	12.6%
Sub-total Population by Race**	181,794	89.48	188,884	85.90%	7,090	3.9%
Persons of Hispanic Descent***	21,377	10.52	31,116	14.1%	9,739	46%
Total Population****	203,171	100.00	220,000	100%	16,829	8.3%

Source: 2000, 2010 Census

Note:

- * Includes non-Hispanic White persons only.
- ** Sub-total population by race includes non-Hispanic persons of all races.
- *** Includes Hispanic persons of all races. This number is computed separately from the total population by race.
- **** Total population by race/ethnicity may not be consistent with population totals cited above. Percent totals may not add up to 100.0% due to rounding.

As the population growth continues as well as its diversity, it is likely that housing needs will be more complex. The population increase of persons 55 years of age and older results in a greater demand for senior housing and for programs to allow “aging in place”. This could lead to adaptations of their homes to suit their needs, or housing that will accommodate their changing lifestyles as they age. The overall diversity and growth of families with children also creates demand for affordable housing opportunities who currently have limited housing choices within the city or the county.

Employment

Employment trends influence the type and cost of housing that residents can afford. The city’s employment base and its ability to attract new types of employers that offer better paying jobs will affect future housing opportunities for its residents.

Table 7 summarizes employment of local residents by industry. Over the past two decades, the services sector employed the largest proportion of residents in the City. Retail trade has been the largest industry sector in the county. The most notable changes in the city’s employment composition were the significant numerical and percentage increases in the Construction and the Education, Health Care and Social Services markets.

Table 7
Employment by Industry, Butte County and City of Gridley

Employment by Industry	Butte County, California		Gridley, California	
	Estimate	Percent	Estimate	Percent
Agriculture, forestry, fishing and hunting, and mining	3,061	3.5	184	8.4
Construction	5,519	6.3	261	11.9
Manufacturing	5,550	6.3	209	9.5
Wholesale trade	1,836	2.1	130	5.9
Retail trade	10,931	12.4	196	9.0
Transportation and warehousing, and utilities	3,131	3.6	125	5.7
Information	1,522	1.7	22	1.0
Finance and insurance, and real estate and rental and leasing	4,357	5.0	72	3.3
Professional, scientific, and management, and administrative and waste management services	8,102	9.2	170	7.8
Educational services, and health care and social assistance	25,935	29.5	390	17.8
Arts, entertainment, and recreation, and accommodation and food services	9,920	11.3	184	8.4
Other services, except public administration	4,440	5.0	100	4.6
Public administration	3,661	4.2	146	6.7
Civilian employed population 16 years and over (Ttl)	87,965		2,189	

Source: ACS DP-03 2007-2011

Historically, the city’s largest employers have been in health care, manufacturing, and public service. Gridley’s work force encompasses professional, technical, production, transportation, and service occupations. Major employers in Gridley span a wide range of sectors, including government,

healthcare, manufacturing and retail, and generally employ between 20 to over 200 employees.

Table 8 summarizes the City’s largest employers. Businesses listed below are located within the city limits as well as close to the urban area.

Employer	Number of Employees
Orchard Hospital	256
Mary's Gone Crackers	250
Gridley Unified School District	225
Wilkerson Ranch & Packing	186
Rio Pluma Manufacturing	70
City of Gridley	56
Residential Weatherization, Inc.	55
Safeway Grocery	53
Continental Athletic Supply	46
Casa Lupe	28
Gridley Country Ford	27
Harshbarger's Ace Hardware	27
Rite Aid	23
Ampla Health	12
Auto Zone	8

Source: Gridley Chamber of Commerce, 2014

Note: Businesses listed are located within the city limits as well as close to the urban boundary.

The California Employment Development Department (EDD) reported a local labor force of 2,800 in 2013. Trends in the City show an increasing unemployment rate, from 2006 of 15.4% to 2010 with a rate of 30.4%. The unemployment rate has been decreasing since that time to the current level of 21.1% dated 2013. **Table 9** summarizes average employment/unemployment rates for Gridley. The higher rates for years 2008 to 2013 reflect the overall poor economic health in the state and nation.

Table 9
Annual Average Employment, City of Gridley

Year	Employed	Unemployed	Unemployment Rate-%
1997	1,690	310	15.4
1998	1,720	300	15
1999	1,760	250	12.3
2000	2,000	300	14.2
2001	2,000	400	14.9
2002	2,000	400	16.6
2003	2,100	400	17
2004	2,000	400	17.2
2005	2,500	400	16
2006	2,100	400	15.4
2007	2,100	400	16.2
2008	2,600	500	18.6
2009	2,100	800	28
2010	2,000	900	30.4
2011	2,000	900	29.9
2012	2,000	800	27.4
2013	2,100	600	21.1

Source: Employment Development Department (EDD- Unemployment rate history for Gridley, 2013.)
<http://www.city-data.com/> Employment Development Department, Labor Market Information

Trends across the state are likely to create continued employment impacts at the county and city levels. The state's unemployment rate rose from 4.9 percent in 2000 to over 12.4 percent in 2010. As of March, 2013, unemployment has continued to decrease to 9% with farm unemployment increasing due to seasonal joblessness. The state experienced job declines in several categories, including construction, manufacturing, professional services, and other service industries from 2008 to 2010. Future unemployment trends in Gridley are expected to reflect changes in the broader economy. The economy is slowly recovering and unemployment rates are decreasing.

Education

Employment type and income reflects the ability to obtain housing. **Figure 2** below compares income for Gridley, California, and the United States. The income for Gridley residents is generally lower; education also plays a key factor in earning power. The data in **Table 10** represents the percentage of people in the area over age 25 that have attained a particular education level.

Table 10
Education level

Education Level	Percent
Did Not Complete High School	29.59%
Completed High School	30.44%
Some College	23.50%
Completed Associate Degree	5.71%
Completed Bachelor's Degree	6.65%
Completed Graduate Degree	4.12%

2010 Household Income Statistics for Gridley, CA

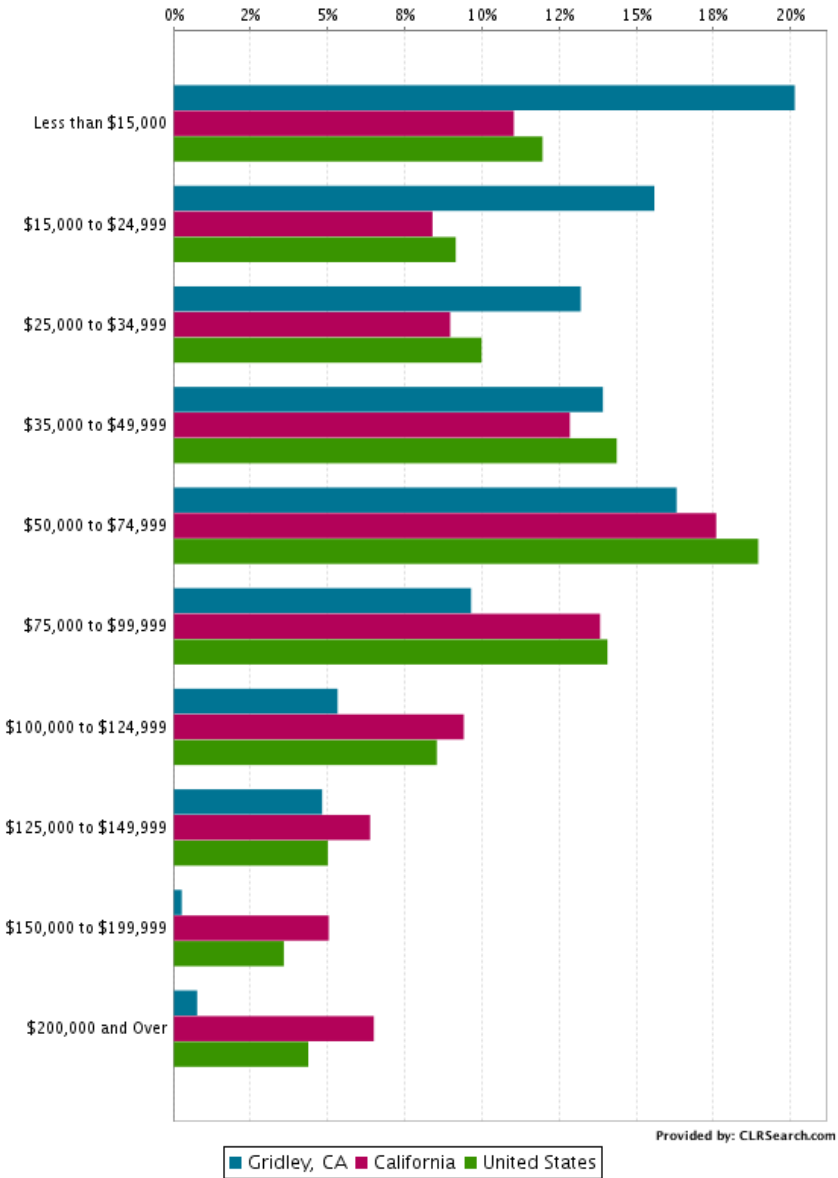

Income

Data on consumer income collected by the Census Bureau covers income received before payments for personal income taxes, social security, union dues, Medicare deductions, etc. Therefore, income does not reflect the fact that some families receive part of their income in the form of non-cash benefits, such as food stamps, health benefits, rent-free housing, and goods produced and consumed.

Figure 2: 2010 Household Income
Source: <http://www.clrsearch.com/gridley-Demographics/CA/Household-Income>

Housing

The city is experiencing continued growth in the number of households forming creating a continued demand for housing. A review of overall household growth and housing stock characteristics, including vacancy rates, age and condition of existing stock, provide an assessment of the type of housing that the city’s residents will need now and over the next eight year period.

Table 11 illustrates the number of households for Gridley and Butte County from 2000 through 2010.

Existing Households	Butte County			Gridley		
Year	# Existing Households	Owner	Renter	# Existing Households	Owner	Renter
2000	79,566	48,336	31,230	1,841	1,051	790
2010	87,618	50,991	36,627	2,183	1,262	921

Source: BCAG Projection data for 2010 and 2020, California DOF Population and Housing Estimates,
* 2.965 Persons per Household

The city added 342 households between 2000 and 2010. This represents an 18.5 percent increase in households during this period. In comparison, the population of Gridley increased by 21.7 percent over the same ten year period, potentially indicating an increasing average household size. Decreasing household sizes is related to both the availability and the affordability of housing in the community.

Housing Tenure

Household formation rate is the prime determinant for housing demand. The number of households can increase or decrease even in periods of static population growth due to adult children leaving home and moving outside the area, divorce, and with the aging of the general population. The ratio between population and households is reflected in the household size, referred to in the U.S. Census as persons per household. The 2010 Census states that the number of persons per household in Gridley is 2.965, which is just slightly higher as reported in 2000 determined as 2.856. As shown in Table 13, over 53% of the home owners are over the age of 45years old while 68% of the rental housing occupants are younger than 45 years of age. This may reflect that younger households are renting units due to a potential lack of affordable housing stock for purchase. Similar trends are apparent in adjacent locales and the county in general.

Table 12
Households by Tenure and Age

	Gridley City, California	Chico, California	Biggs City, California	Oroville, California	Paradise, California	Butte Countywide Total
Total:	1,958	33,891	623	5,675	11,519	85,219
Owner occupied:	1,119	15,206	388	2,483	8,329	51,406
Householder 15 to 24 years	34	168	5	67	55	511
Householder 25 to 34 years	102	1,545	47	258	397	3,506
Householder 35 to 44 years	139	2,689	56	374	674	6,926
Householder 45 to 54 years	249	3,457	82	348	1,804	10,881
Householder 55 to 59 years	218	1,749	50	311	965	6,243
Householder 60 to 64 years	110	1,710	36	361	1,036	6,071
Householder 65 to 74 years	119	1,721	66	363	1,391	8,717
Householder 75 to 84 years	106	1,639	20	293	1,274	6,105
Householder 85 years and over	42	528	26	108	733	2,446
Renter occupied:	839	18,685	235	3,192	3,190	33,813
Householder 15 to 24 years	59	5,896	38	455	151	7,305
Householder 25 to 34 years	193	4,647	72	650	579	8,151
Householder 35 to 44 years	320	1,975	33	468	521	4,985
Householder 45 to 54 years	83	2,646	4	542	392	4,976
Householder 55 to 59 years	17	1,039	46	182	321	2,287
Householder 60 to 64 years	12	862	20	374	367	1,989
Householder 65 to 74 years	122	715	9	265	255	1,970
Householder 75 to 84 years	33	399	13	163	244	1,084
Householder 85 years and over	0	506	0	93	360	1,066

Source: ACS 2011; 5 year (HCD)

Housing stock characteristics

An assessment of housing type, tenure, and cost are important to identify future housing needs. A majority of the housing units are single-family homes. According to the ACS 2011, 57% of the homes in Gridley are owned.

Table 13 compares the available housing types in 2000, and 2010 to other municipalities and the county. According to the Department of Finance data, between 2000 and 2010, 433 housing units were constructed in Gridley. The analysis of units gained in the Annual Reports calculated 641 units gained overall. This discrepancy may be due to the timing of data gathering. A majority of the growth in housing units has been single-family, detached homes composing 88 percent of the housing stock; 2,115 of the total 2,406 units. The vacancy rate has nearly doubled from 2000 to 2010, while the persons per household have increased.

Table 13
City/County Population and Housing Estimates, 2000 and 2010
HOUSING UNITS

County / City	Date	Total Housing Units	Single	Multiple	Mobile Homes	Households	Vacant Units	Vacancy Rate	Persons Per Household
Butte County									
Biggs	4/1/2000	613	533	33	47	571	42	6.85%	3.140
	4/1/2010	617	594	4	19	565	52	8.43%	3.021
	10-year change	0.7%	11.4%	-87.9%	-59.6%	-1.1%	23.8%		
Chico	4/1/2000	24,386	12,819	10,934	633	23,476	910	3.73%	2.423
	4/1/2010	37,050	21,470	13,625	1,955	34,805	2,245	6.06%	2.385
	10-year change	51.9%	67.5%	24.6%	208.8%	48.3%	146.7%		
Gridley	4/1/2000	1,973	1,623	276	74	1,851	122	6.18%	2.856
	4/1/2010	2,406	2,115	213	78	2,183	223	9.27%	2.965
	10-year change	21.9%	30.3%	-22.8%	5.4%	17.9%	82.8%		
Oroville	4/1/2000	5,419	3,013	2,027	379	4,881	538	9.93%	2.496
	4/1/2010	6,194	3,846	1,969	379	5,646	548	8.85%	2.597
	10-year change	14.3%	27.6%	-2.9%	0.0%	15.7%	1.9%		
Paradise	4/1/2000	12,374	8,874	1,031	2,469	11,591	783	6.33%	2.225
	4/1/2010	12,981	9,341	1,500	2,140	11,893	1,088	8.38%	2.170
	10-year change	4.9%	5.3%	45.5%	-13.3%	2.6%	39.0%		
Unincorporated	4/1/2000	40,758	27,179	2,986	10,593	37,196	3,562	8.74%	2.564
	4/1/2010	36,587	25,754	1,324	9,509	32,526	4,061	11.10%	2.564
	10-year change	-10.2%	-5.2%	-55.7%	-10.2%	-12.6%	14.0%		

Source: DOF 2008-2010 By Geography

The City of Gridley has increased the number of units by 21.9%. This increase reflects the second highest community to add units within the 10 year period. Chico had a ten year unit gain of 51.9%. Oroville followed Gridley with a gain of 14.3%, Paradise with 4.9%, Biggs with 0.7% and the county overall had a unit decrease of 10.2% of all units.

Vacancy

Vacancy trends in housing are analyzed using a “vacancy rate” which establishes the relationship between housing supply and demand. For example, if the demand for housing is greater than the supply, then the vacancy rate will probably be low and the price of housing will most likely increase.

According to “Raising the Roof, California Housing Development Projections and Constraints, 1997-2020”, states that when the overall vacancy rate drops below 5 percent, the demand exceeds the available

supply. Generally, a vacancy rate of about 2 percent for ownership housing and 6.0 to 7.0 percent for rental housing is considered to be “normal.”

According to the Department of Finance, Census 2010, the vacancy rate for owner housing units was 2.6 percent and 6.5 percent for rental housing units. Generally, these rates are consistent with what are considered “normal” vacancy rates for owner- and renter-occupied units and indicate a housing market in balance. **Table 14** shows the vacancy rates for the incorporated cities and within Butte County.

City vacancy rates have increased since 2000 in each community as shown in **Table 13** above.

Table 14
Vacancy Rates in Butte County, Incorporated and Unincorporated Areas

City	Ownership Housing Vacancy Rate (%)	Rental Housing Vacancy Rate (%)
Biggs	3.2	6.5
Chico	2.0	5.8
Gridley	2.6	6.5
Oroville	3.6	8.4
Butte	2.4	6.4

Source: DOF Census 2010 Demographic Summary Profile

The majority of available vacant units are rental units followed by for-sale units as shown in **Table 15**, below.

Table 15
Housing Vacancy

	Gridley		Butte County	
	Number	Percent	Number	Percent
Vacant housing units	223	9.3	8,217	8.6
For rent	64	2.7	2,498	2.6
For sale only	34	1.4	1,256	1.3
Rented or sold, not occupied	8	0.3	466	0.5
For seasonal, recreations., or occasional use	8	0.3	1,831	1.9
For migrant workers	Not available	Not available	Not available	Not available
Other vacant	109	4.5	2,166	2.3

Source: DOF Census 2010 Demographic Summary Profile

Age and condition of housing

The age of housing, by itself, does not necessarily equate with poor housing conditions. However, a neighborhood with a large stock of older housing (particularly older non- subsidized rental housing) occupied by a high percentage of lower-income households has a much greater potential for housing problems compared to an affluent neighborhood with older housing.

If not properly maintained, housing can exhibit obvious signs of “wear and tear” after 30 years or less

depending on the quality of materials and construction. Non- structural components such as paint, siding, doors, windows, roof shingles, electrical, plumbing, and ventilation can deteriorate or fail during the first 30 years. Housing can exhibit structural problems after 40 years or more; sagging roofs, foundation failure, walls out of plumb, etc. if subject to inadequate maintenance and repairs.

Table 16 below provides the age of the housing units in Gridley. The census reports that:

- 55.6 percent (1,312) of all housing units were built before 1970;
- 20 percent (477 units) of all housing units were built between 1940 and 1949; and,
- 31 percent (738) of all housing units have been built since 1980.

The median years for housing built are 1950 to 1959, indicating a relatively older housing stock, in general.

Table 16
Housing Units by Year Built

Year Built	Number	Percent	Accumulated Percent
1939 or earlier	337	14.3	14.3
1940 to 1949	477	20.2	34.5
1950 to 1959	262	11.1	45.6
1960 to 1969	236	10	55.6
1970 to 1979	311	13.2	68.8
1980 to 1989	214	9.1	77.9
1990 to 1999	149	6.3	84.2
2000 to 2009	375	15.8	100.0
Total	2,361	100.0	

Source: 1990, 2000 Census; 2010 of Gridley

As noted above, the majority of the housing held by homeownership is by residents 45 years and older with rental housing occupied by younger residents. The majority of the housing stock is owner occupied, representing 56 percent of the total housing units built by 2000. **Figure 3** illustrates the age of housing units by tenure. According to these figures, the 58.8 percent of renters live in housing units built before 1960. The largest proportion, 57.4 percent, of renter-occupied housing units was built between 1940 and 1949. Comparatively, 69.8 percent of the housing units in the city built between 1950 and 1959 are occupied by owners. A total of 1,312 units were built prior to 1970 and may potentially need rehabilitation. Data was not available in this format from the 2010 Census; however, the trends found in Figure 3 are consistent today.

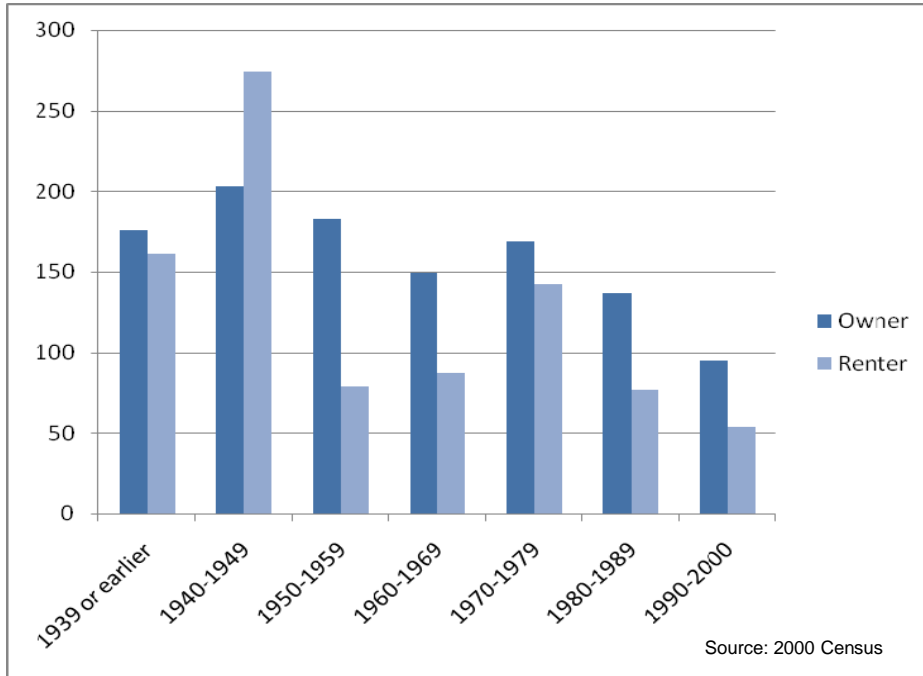

Figure 3: Age of Housing by Tenure

The City of Gridley Planning Department conducted a housing survey in 2014. This included a visual survey of 2,450 housing units to observe degradation of non-structural components, such as siding, windows, electrical systems, and structural components, such as foundation failure. The sample form provided by the State Housing and Community Development was used. Of the surveyed housing stock, approximately 55% percent were found in need of minor repairs primarily considered as aesthetic (paint, landscape maintenance, curb appeal), including 35 percent in need of moderate repairs (reroof, window replacement, exterior cracking/siding repair) and approximately 9 percent that were found to be in need of substantial repairs. The remaining 1 percent were dilapidated or required much more structural rehabilitation or consideration of demolition.

Based on these figures, a total of approximately 472 housing units may be in need of minor aesthetic improvements and 220 housing units may be in need of major rehabilitation over the next housing period. Approximately 25 units may need to be replaced.

Housing cost, affordability, and income

The relationship of housing cost to income has the potential to create an unmet need if cost increases faster than income. If the housing cost is relatively high in comparison to household income, a correspondingly higher prevalence of cost burden (payment of more than 30 percent of income for housing) and overcrowding (more than one person per room) will result. This section summarizes the cost and affordability of the Gridley housing stock to residents.

Affordability is based on a household spending 30 percent or less of their total income for shelter costs. Shelter costs include mortgages/rent, property taxes, property insurance, and utilities. The Department of Housing and Community Development has established maximum household income levels based on a percentage of median income; for extremely low income (30%), very low income (50%), low income (80%), moderate income, and above moderate income.

The 2014 Butte County income limits established by the state are defined in **Table 17** below:

Income Level		Number of Persons in Household							
		1	2	3	4	5	6	7	8
Butte County 4-person Area Median Income \$58,700	Extremely Low (30%)	12,350	14,100	15,850	17,600	19,050	20,450	21,850	23,250
	Very Low (50%)	20,550	23,500	26,450	29,350	31,700	34,050	36,400	38,750
	Low Income (80%)	32,900	37,600	42,300	46,950	50,750	54,500	58,250	62,000
	Median Income	41,100	46,950	52,850	58,700	63,400	68,100	72,800	77,500
	Moderate Income	49,300	56,350	63,400	70,450	76,100	81,700	87,350	93,000

Source: Department of Finance

As shown in **Table 18** below, the maximum affordable monthly housing available funds for extremely-low and very low-income, four-person households is \$440 and \$733.75, respectively.

Income Category	1	2	3	4	5	6	7	8
Extremely Low	\$308.75	\$352.50	\$396.25	\$440.00	\$476.25	\$511.25	\$546.25	\$581.25
Very Low	\$513.75	\$587.50	\$661.25	\$733.75	\$792.50	\$851.25	\$910.00	\$968.75
Low	\$822.50	\$940.00	\$1,057.50	\$1,173.75	\$1,268.75	\$1,362.50	\$1,462.25	\$1,550.00
Median	\$1,027.50	\$1,173.75	\$1,321.25	\$1,467.50	\$1,585.00	\$1,702.50	\$1,820.00	\$1,937.50
Moderate	\$1,232.50	\$1,408.75	\$1,585.00	\$1,761.25	\$1,902.50	\$2,042.50	\$2,183.75	\$2,325.00

Note: Affordable housing costs assume that 30% of gross household income is applied toward shelter costs.
Source: 2014 Income Limits, Department of Housing and Community Development

Rental housing

According to **Table 19** below, a two-bedroom unit has a cost range of \$600-\$800, and a three-bedroom unit has a cost range of \$850-\$1,000 for rent for a four person household. This would indicate that while a portion of rental units in the city may be affordable to very low-income households, most market rentals are not within the affordability range for extremely low income households. The affordability range for a three-bedroom unit is \$850-\$1,000 thus restricting affordable housing availability to both extremely low and very low income households.

**Table 19
Rental Costs**

Bedrooms	Rental Range
1	\$500-\$750
2	\$600-\$800
3	\$850-1,000

Sources: Butte County Apartments, April 2014

Ownership housing

Between 2000 and 2006, sales prices for single-family homes in the city and county experienced an average annual increase of 8.6 percent and 9.1 percent, respectively. Home sales prices are historically higher countywide, with an average difference of 2 percentage points.

Gridley’s median sales prices peaked at \$282,000 in 2006 and experienced a 37.2 percent decrease in the following two-year period. Median sales prices in the city were estimated at \$177,000 for single-family homes. The decline of housing prices during this time period and forward into 2010 is directly related to the economic recession both the state and nation have experienced.

In the six-month period between July, 2013 and February, 2014, 62 homes were listed for sale in the Gridley area. All of these were single-family homes. Median sale prices by bedroom size ranged from \$148,200 for a two- bedroom to \$346,317 for a four-bedroom listing. **Table 20** summarizes the number of recently sold homes. Three-bedroom homes were the most commonly listed home size, accounting for 52 percent of all sales; the median sales price was lower than for a two bedroom home.

Declines in housing prices are attributed to a variety of factors in the broader economy, including a slowdown in the housing market, tightening credit, and continued foreclosures. These factors are expected to continue, though lessening, as the market continues to recover. Analysts indicate home sales are increasing, however credit remains tight and fewer mortgages are being applied for resulting in two conditions: a continued reduction in housing availability and a continued lack of home building construction.

**Table 20
Recently Sold Homes (July, 2013-February, 2014)**

Bedrooms	Listing	Median Sale Price
1	-	-
2	20	\$148,200
3	32	\$141,097
4	10	\$346,317
5+	0	\$0--
Total	62	

Source: realtytrac.com - 2014

Overpayment

Overpayment for housing is defined as shelter costs in excess of 30 percent. According to the Census data, 39.2 percent of owner households and 63.1 percent of the renter households in the City were overpaying for housing. **Table -21** summarizes data from the 2007-2011 ACS Census data, the percentage of overpayment for rental and owner occupied housing. This information shows the extremely-low and very low income levels are spending an average of 72.5 percent for shelter costs in Gridley of all households (avg of 77.5% and 67.4%). However, what is also shown is that all income levels are struggling and most are paying greater than the 30% of available income and overpaying for shelter excepting the above moderate income group.

Table 21
Households by Income Category Paying in Excess of 30%
of Income Toward Housing Cost (Overpayment By Income category)

AMI 58,700	Gridley						
	Extreme Low	Very Low	Low	Moderate	Above Moderate	Total	Lower income
Household							
Ownership Households	158	145	252	168	313	1,036	555
Overpaying Owner Households	126	85	73	84	38	406	284
Percentage of Overpaying Owners	79.9%	58.5%	29.0%	49.9%	12.1%	39.2%	51.2%
Renter Households	237	195	225	43	10	711	658
Overpaying Renter Households	180	145	91	24	10	449	415
Percentage of Overpaying Renters	75.8%	74.0%	40.4%	54.6%	100.0%	63.1%	63.1%
Total Households	394	341	477	212	323	1,748	1,213
Overpaying Households	306	230	164	108	48	855	699
Percentage of Overpaying Households	77.5%	67.4%	34.3%	50.9%	14.9%	48.9%	57.7%

Source: ACS 2007-2011 B25106 (HCD)

According to the ACS data, a greater percentage of extremely low and very low-income renter than owner households paid 30 percent or more of their income on housing. Owner housing paid more than 50% of their income in the extremely low income households and 17% paid more than 50% of their income in the low income households. All income groups paid generally more than 30% of their income on housing whether an owner or a renter in the extremely low, very low and low income groups.

Extremely low and very low income households are most affected by cost burden, paying more than 50 percent of their income on housing. **Table 22** summarizes the proportion of overpaying households by tenure. In regards to renters, small related extremely low and low income households with two to four members are most affected by cost burden, paying more than 50 percent of their income on housing.

**Table 22
Household Type and Cost**

Household Type and Cost Burden	Renters	Owners	Total
Extremely Low Income (0-30% MFI)	145	170	315
Housing Cost>30% of Income	88%	84%	86%
Housing Cost>50% of Income	64%	84%	70%
Very Low Income (31-50% MFI)	245	305	550
Housing Cost>30% of Income	78%	49%	63%
Housing Cost>50% of Income	17%	17%	17%
Low Income (51-80% MFI)	470	275	745
Housing Cost>30% of Income	47%	54%	57%
Housing Cost>50% of Income	8%	10%	9%
Moderate and Above Moderate (>81%MFI)	80	240	320
Housing Cost>30% of Income	0	7%	5%
Housing Cost>50% of Income	0	0	0
Total Households	940	990	1930
Housing Cost>30% of Income	55%	28%	39%
Housing Cost>50% of Income	24%	11%	16%

Source: CHAS Data Book, 2010

Overcrowding

Overcrowding is defined as a situation where there is more than one person per room in an occupied using unit. Overcrowding can result from a low supply of affordable and adequate housing. Households that are unable to afford larger housing units or unable to find vacant larger housing units in an area may be forced to rent or purchase housing that is too small to meet their needs. According to the 1990 Census, 7.9 percent of households in Gridley lived in overcrowded conditions. According to the 2000 Census, the number of overcrowded households has increased by 104 (representing 11.6 percent of the total households in the city). It is anticipated that overcrowding will continue to rise in the near term.

As **Table 23 below**, shows, the level of overcrowding by tenure is greater in the owner occupied households. In both overcrowded and severely overcrowded, Butte County has more households renting with overcrowding 30-50% greater than owner occupied housing. Gridley an opposite effect with overcrowding greater in owner occupied housing instead of rental housing in both overcrowded and severely overcrowded (1.5 persons per room or more) households.

Table 23
Overcrowded Households in
Butte County and the City of Gridley

		Butte County, California		Gridley, California
		Estimate		Estimate
Total:		85,219		1,958
Owner occupied:		51,406		1,119
	0.50 or less occupants per room	39,131		702
	0.51 to 1.00 occupants per room	11,207		352
	1.01 to 1.50 occupants per room	835		18
	1.51 to 2.00 occupants per room	158		33
	2.01 or more occupants per room	75		14
Renter occupied:		33,813		839
	0.50 or less occupants per room	19,771		355
	0.51 to 1.00 occupants per room	12,152		448
	1.01 to 1.50 occupants per room	1,300		36
	1.51 to 2.00 occupants per room	331		0
	2.01 or more occupants per room	259		0
Owner Occupied	Overcrowded	1.01 or more	1068	65
Renter occupied	Overcrowded	1.01 or more	1890	36
Total overcrowded		1.01 or more	2958	101
Owner Occupied	Severely Overcrowded	1.5 or more	233	47
Renter occupied	Severely Overcrowded	1.5 or more	590	0
Total severely overcrowded		1.5 or more	823	47

Source: ACS 2007-2011 Table B25014

Special housing needs

Household groups with special needs include disabled persons, female headed households, large family households, seniors, agricultural farm workers, and homeless persons. Households with special housing needs often have greater difficulty in finding decent and affordable housing. As a result, these households may experience a higher prevalence of overpayment for housing, overcrowding, and other housing problems. Extremely low income households share many of the special needs housing as described and as previously analyzed in “Housing Affordability”, above.

Housing elements must include an analysis of the special housing needs of the disabled including persons with developmental disabilities. Special needs groups often spend a disproportionate amount of their income to secure safe and decent housing and are sometimes subject to discrimination based on their specific needs or circumstances. Chapter 507, Statutes of 2010 (SB 812), which took effect January 2011, amended State housing element law to require the analysis of the disabled to include an evaluation of the special housing needs of persons with developmental disabilities.

Table 24
Developmentally Disabled

Age	Residence	Number
3 to 5 yrs	Home Prnt/Grdn	17
6 to 9 yrs	Home Prnt/Grdn	19
10 to 13 yrs	Home Prnt/Grdn	12
14 to 17 yrs	Home Prnt/Grdn	10
18 to 21 yrs	Home Prnt/Grdn	6
22 to 31 yrs	Home Prnt/Grdn	11
22 to 31 yrs	Indep Living	6
32 to 41 yrs	Home Prnt/Grdn	7
32 to 41 yrs	Indep Living	2
42 to 51 yrs	Community Care	3
42 to 51 yrs	Home Prnt/Grdn	4
42 to 51 yrs	Indep Living	3
52 to 61 yrs	Community Care	2
52 to 61 yrs	Home Prnt/Grdn	1
52 to 61 yrs	Indep Living	3
52 to 61 yrs	SNF	1
62 and Older	Community Care	1
62 and Older	Indep Living	1
62 and Older	SNF	1
	Total	110

There are a number of housing types appropriate for people living with a development disability: rent subsidized homes, licensed and unlicensed single-family homes, inclusionary housing, Section 8 vouchers, special programs for home purchase, HUD housing, and SB 962 homes. The design of housing-accessibility modifications, the proximity to services and transit, and the availability of group living opportunities represent some of the types of considerations that are important in serving this need group.

Developmentally disabled

According to Section 4512 of the Welfare and Institutions Code a "Developmental disability" is defined as a disability that originates before an individual attains age 18 years, continues, or can be expected to continue, indefinitely, and constitutes a substantial disability for that individual which includes mental retardation, cerebral palsy, epilepsy, and autism. This term shall also include disabling conditions found to be closely related to mental retardation or to require treatment similar to that required for individuals with mental retardation, but

shall not include other handicapping conditions that are solely physical in nature.

The US Census does not have specific information regarding persons with developmental disabilities. However, each non-profit regional center contracted with the California Department of Developmental Services (DDS) maintains an accounting of the number of persons served by zip code or city. This information can be used to estimate the number of persons residing in the jurisdiction which have developmental disabilities.

The development of affordable and accessible homes is critical to expand opportunities for persons with developmental disabilities to live in integrated community settings. One of the biggest obstacles to living independently in the community is a lack of financial resources. Income is often limited and affordable housing where people can rent homes, apartments, duplexes, or mobile homes is crucial to the long term stability of a person with developmental disabilities. In addition, access to various types of supported living services is critical for persons with developmental disabilities to live as independently as possible.

Many developmentally disabled persons can live and work independently within a conventional housing environment. More severely disabled individuals require a group living environment where supervision is provided. The most severely affected individuals may require an institutional environment where

medical attention and physical therapy are provided. Because developmental disabilities exist before adulthood, the first issue in supportive housing for the developmentally disabled is the transition from the person’s living situation as a child to an appropriate level of independence as an adult.

The State Department of Developmental Services (DDS) currently provides community based services to approximately 243,000 persons with developmental disabilities and their families through a statewide system of 21 regional centers, four developmental centers, and two community-based facilities. The Far Northern Regional Center is one of 21 regional centers in the State of California that provides point of entry to services for people with developmental disabilities in Butte County. The center is a private, non-profit community agency that contracts with local businesses to offer a wide range of services to individuals with developmental disabilities and their families.

The following information from the Far Northern Regional Center, charged by the State of California with the care of people with developmental disabilities, defined as those with severe, life-long disabilities attributable to mental and/or physical impairments provides a closer look at the disabled population in Gridley. **Table 25** below depicts the community partnership with Far Northern to employ those with a physical disability.

The 2000 Census identified six types of disabilities: Sensory, physical, mental, self-care, go-outside-of-home, and employment disabilities. **Table 26** summarizes types of disabilities amongst Gridley’s disabled population. Approximately 24% of Gridley’s civilian, non-institutionalized population 5 years and older had some type of disability. The most prevalent type of disability is a physical disability (17.9 percent of those with some type of disability).

Table 25
Persons with Physical Disability by Employment Status*

	Butte County		Gridley	
	Number	Percent	Number	Percent
Age 5-64, Employed Persons with a Disability	2937	13.41%	65	10.09%
Age 5-64, Not Employed Persons with a Disability	8951	40.86%	223	34.63%
Persons Age 65 Plus with a Disability	9459	43.18%	356	55.28%
Total Persons with a Physical Disability	21907	100%	644	100%
% of Total Population Over Age 5 (Civilian Non-institutional)	11.54%		0.34%	

Source: 2000 Census PCT028

*Employment data for all disabilities not considered physical is not available for all jurisdictions.

Table 26
Persons with Disabilities by Disability Type and Age

	Butte		Gridley	
	Number	Percent	Number	Percent
Total Disabilities Tallied	80,102	100.00	2,183	100.00
Total Disabilities for Ages 5-64	53,019	66.19	1274	58.36
Sensory Disability	4,128	5.15	166	7.60
Physical disability	12,448	15.54	288	13.19
Mental disability	10,211	12.75	189	8.66
Self-care disability	3,823	4.77	59	2.70
Go-outside-home disability	7,572	9.45	166	7.60
Employment disability	14,837	18.52	406	18.60
Total Disabilities for Ages 65 and Over	27,083	33.81	909	41.64
Sensory Disability	5,256	6.56	142	6.50
Physical disability	9,459	11.81	356	16.31
Mental disability	3,780	4.72	92	4.21
Self-care disability	3,042	3.80	84	3.85
Go-outside-home disability	5,546	6.92	235	10.77

Source: 2000 Census PCT028 (HCD)

Physical, mental, and/or developmental disabilities could prevent a person from working, restrict a persons' mobility, or make caring for oneself difficult. Therefore, disabled persons often require special housing needs related to potential limited earning capacity, the lack of accessible and affordable housing, and higher health costs associated with disabilities. The 2000 CHAS data shows 534 households with disabilities, including senior households with disabilities. Of these, over 25.8 percent (138 households) were VLI households and 18.1 percent (97 households) were ELI households.

Additionally, people with disabilities may require a wide range of housing and supportive services, depending on the type and severity of their disabilities. Housing needs can range from institutional care facilities to facilities that support partial or full independence (i.e., group care homes). Supportive services such as daily living assistance and employment assistance may also be needed, ideally integrated with housing.

Disabled persons with mobility limitations require housing that is physically accessible. Examples of accessibility in housing include widened doorways and hallways, ramps, bathroom modifications (i.e., lowered countertops, grab bars, adjustable shower heads, etc.) and special sensory devices including smoke alarms and flashing lights. Incorporating 'barrier-free' design in all, new multifamily housing (as required by California and Federal Fair Housing laws) is especially important to provide the widest range of choices for disabled residents. Special consideration should also be given to the affordability of housing, as people with disabilities may be living on a fixed income.

According to the Census, 69 persons in the city reside in “nursing homes.” Of these, a majority (61 persons) is 65 years old or older. Nursing homes are defined as skilled-nursing facilities, intermediate-care facilities, long-term care rooms in wards or buildings on the grounds of hospitals, or long-term care rooms/nursing wings in congregate housing facilities. Also included are nursing, convalescent, and rest homes.

Five residential care facilities are located in the city, which provide assistance to persons 60 years of age and older and to persons with disabilities, and two additional residential care facilities provide assistance to developmentally disabled adults ages 18-59.

In conclusion, between 2000 and 2008 it is estimated that the number of persons with a disability increased by approximately 13.5 percent, or 87 additional persons, ages 5 to 64. Persons over 65 with a disability are counted as part of the senior household projections.

In order to assist in the housing needs for persons with developmental disabilities, the city will implement programs to coordinate housing activities and outreach with the Far Northern Regional Center, encourage housing providers to designate a portion of new affordable housing developments for persons with disabilities, especially persons with developmental disabilities, and will pursue funding sources designated for persons with special needs and disabilities.

Female headed households and single parent

Single-parent households are households with children under the age of 18 at home and are generally female-headed households. However, single parent households are also male headed households. These households generally have a higher ratio between their income and their living expenses. Living expenses take up a larger share of income than is generally the case in two-parent households, therefore, finding affordable, decent, and safe housing is often more difficult for single-parent households to acquire. Additionally, single-parents have special needs involving access to daycare or childcare, health care, and other family support services.

According to Census 2010 data, 11.3 percent or 247 of all households, in the city of Gridley are headed by single parents with children under the age of 18. The majority of single-parent households in the city of Gridley are female-headed comprising 176 households equaling approximately 71 percent. This data indicates that 29 percent of single-parent households in the city that are headed by a male, with no female present and having related children under the age of 18 present in the home.

Large family households

Large family households are defined as households containing five or more persons. Large family households are considered a special needs group because there is limited supply of adequately sized housing to accommodate their needs. The more persons in a household, the more rooms are needed to accommodate that household. Specifically, a five-person household would require three or four bedrooms, a six-person household would require four-bedrooms, and a seven-person household would require four to six bedrooms.

According to the 2010 Census, 20 percent of all households in Gridley include five or more persons (435 households). Gridley’s housing stock provides a good supply of larger owner-occupied housing compared to large households. There were 255 large owner households and 702 owner occupied housing units of three or more bedrooms. Compared to owner occupied units, there are fewer large rental

units compared to large households. There were 180 large renter households and 172 rental housing units of three or more bedrooms in the city in 2000. **Table 27** summarizes the number of large households and housing units.

Table 27			
Large Households and Housing Units			
Owner			
5-Person	128	9.1%	3-Bedrooms
6-Person	64	6.9%	4-Bedrooms
7-Person or more	63	2.6%	5-Bedrooms or more
Sub Total	255	20.5%	
Renter			
5-Person	103	5.4%	3-Bedrooms
6-Person	38	4.1%	4-Bedrooms
7-Person or more	39	4.1%	5-Bedrooms or more
Sub Total	180	13.5%	
Total	435		

Source: 2010 Census

Senior households

The age of senior citizens varies depending upon the benefits to be gained. Legally for purposes of social security retirement benefits the age is from 65-68 depending on birthdate, the age for senior discounts is generally 60-62, the age for senior apartments for federal housing subsidies is 62, with some further age restricted housing developments from the age of 55-58. The Housing Element uses the social security benefits age of 65 years and older.

Seniors may have special housing needs resulting primarily from physical disabilities and limitations, fixed income, and health care costs. Additionally, senior households also have other needs to preserve their independence including protective services to maintain their health and safety, in-home support services to perform activities of daily living, conservators to assist with financial affairs including management of estate issues and networks of care to provide a wide variety of services and daily assistance. In 2000, the city had 857 persons 65 years old or older. According to the 2010 Census, the city's senior population increased by 1.2 percent to 928 persons. The 1.2% increase in the senior population for the 2000-2010 ten year period is substantially higher than the 0.3 percent annual increase of the previous ten year period from 1990 to 2000.

Table 28 summarizes Gridley's senior population by gender. The majority of the senior population in the 2010 Census is female representing 60.2 percent. Seniors over 80 years of age represent 30.9 percent of the total senior population in the city disability (17.9 percent of those with some type of disability). In addition, 588 of the householders in Gridley are seniors, which accounts for 27 percent of the households in the city. As a group, senior households have lower incomes than the average household in Gridley. The senior population has approximately 46 percent living in extremely low income households and approximately 29 percent living in very low income households. Seniors have slightly lower home ownership rates than the population at large,

Table 28
Senior Population by Gender

Age of Seniors	Male			Female		
	Number	Percent	% of Total	Number	Percent	% of Total
65 to 69 years	115	31	12.4	133	23.8	14.3
70 to 74 years	85	23	9.2	150	26.8	16.2
75 to 79 years	73	19.9	7.9	85	15.2	9.2
80 to 84 years	46	12.5	4.9	78	14	8.4
85 years and over	50	13.6	5.4	113	20.2	12.1
Total	369	100.0	39.8	559	100.0	60.2

with a home ownership rate of approximately 64.5 and a rental rate of 35.4 percent. **Table 29** summarizes senior householders by tenure.

Table 29
Senior Householders by Tenure

Age	Number	Percent	Percent of Total
Renter Occupied Households			
65 to 74 years	94	45.2	16
75 to 84 years	71	34.1	12.1
85 years and over	43	20.7	7.3
Sub total	208	100.0	35.4
Owner Occupied Households			
65 to 74 years	192	50.5	32.7
75 to 84 years	126	33.2	21.4
85 years and over	62	16.3	10.5
Subtotal	380	100.0	64.5
Totals - Renter and Owner Occupied Households			
65 to 74 years	286	48.6	
75 to 84 years	197	33.5	
85 years and over	105	17.9	
Total	588	100.0	

Source: 2010 Census

Homeless persons

Homeless individuals and families have perhaps the most immediate housing need of any group. They also have one of the most difficult sets of housing needs to meet, due to both the diversity and complexity of the factors that lead to homelessness, and to community opposition to the siting of facilities that serve homeless clients. State law requires that housing elements estimate the need for emergency shelter for homeless people. An accurate count of the homeless population can be difficult to ascertain, as by their very nature homeless persons are transient and do not live in conventional housing. Nevertheless, the Butte County Continuum of Care (CoC) undertook a point-in-time census of the County’s homeless population. On January 27, 2011, volunteer enumerators conducted a street-based and service-based enumeration to obtain an unduplicated count of homeless individuals and families in the county on a given day. As shown in **Table 30** the 2011 Point in Time Homeless Count Report found 1,772 homeless individuals living in Butte County and 97 living in Gridley. However, the Community Action Agency of Butte County which conducted the final reporting of the census estimates that this number is lower than the actual number of persons living in the Gridley area, as inclement weather conditions on that day may have resulted in an undercount. Approximately 215 children with families and 36 unaccompanied youth live within the county. Approximately 319 individuals were identified as chronically homeless. The count of homeless persons was updated in January of 2011. This effort identified 1,772 individuals experiencing homelessness in Butte County. The summary of this survey discovered that:

- ✓ 12% of the homeless respondents reported having children
- ✓ 30% were unsheltered (living outdoors)
- ✓ 32% were sharing the housing of family and friends
- ✓ 48% reported having no financial resources
- ✓ 60% reported having lived in Butte County for 5 years or longer
- ✓ 18% were “chronically homeless”
- ✓ 27% reported having some college level education

Gridley does not currently have any homeless shelters. The closest homeless shelter and services for the homeless individuals and families are located in the City of Marysville or the City of Chico. Gridley modified its municipal code to allow emergency and transitional shelters in the Public and Quasi-Public (PQP) zone in the city for a period of six months. However, State law (Government Code 65583 (4) (A) requires that emergency shelters be permitted by right in one or more zones on a year round basis. The Zoning Ordinance will be updated to comply with the provision of State law. Please refer to the Housing Plan section for information on the city’s housing policies and programs.

**Table 30
Homeless Population**

	Sheltered	Unsheltered	Other	Total
Adults				1170
Children (w/families)				215
Unaccompanied Youth				36
Adults in Families				387
Total	665	540	567	1772
	Community/Location			
	Sheltered	Unsheltered	Other	Total
Gridley	0	53	44	97
Chico	430	304	309	1043
Oroville	153	157	235	545
Paradise	1	28	42	71
Other	0	4	12	16
Total	584	546	642	1772

Farmworkers

Farmworkers often face particular difficulties obtaining safe, decent, and affordable housing. Farmworker households may be forced to occupy substandard and/or overcrowded homes due to their low income status and traditionally have low home ownership rates.

At the time of the 2000 Census, approximately 235 farmworkers lived within the city of Gridley. Based on a market study commissioned by the Housing Authority of the county of Butte (HACB) in 2008, the number of farmworkers in the city is estimated to have increased by 1.26 percent annually since 2000, or approximately 260 farmworkers in 2008. The EDD estimates mean farm labor wages between nine and eleven dollars an hour depending on the type of farm labor, making farmworkers in Gridley low income minimum wage earners. The current minimum wage is \$9.00 per hour increasing in January, 2015 to \$10.00.

The California EDD projects an average 11.2 percent countywide decline in all farm labor by 2016, but provides no specific factors for this decrease. Based on conversations with property managers and job training specialists in the region, the HACB attributes this decrease to various factors, including increased agricultural mechanization, the replacement of high intensity crops with less labor intensive crops, increased development on agricultural lands, and the transition out of farm labor jobs into other non-farm types of employment, such as construction. The HACB projects an overall decline in the farmworker population, and a subsequent decline in the demand for farmworker housing in Gridley and surrounding areas. As such, strategies to assist very low-income housing needs will also benefit farmworkers.

Currently, there is one farmworker housing site owned and operated by the HACB. It contains 112 units for low and moderate income farmworkers. Based on increasing vacancy rates in the housing site and a projected future decline in the demand for farmworker housing, the HACB does not have plans to develop further new farmworker housing in the immediate future.

The city's Zoning Ordinance currently allows agricultural employee housing in the agricultural zoning districts in the city. State law (Health and Safety Code Sec. 17021.6) requires jurisdictions to consider agricultural employee housing as a permitted use in all agriculturally zoned districts within that jurisdiction. Amendments to the code were adopted in 2011; however, the city will review and revise this code to meet the most current agricultural housing requirements within the 8 year planning period. Please refer to the Housing Plan for description of a program to update the Zoning Ordinance to comply with state law, as required.

Chapter 3: OPPORTUNITIES FOR ENERGY CONSERVATION

State law requires municipalities to include an analysis of opportunities for residential energy conservation in its Housing Element (Government Code Part 65583 [a] [7]). Opportunities for residential energy conservation exist at all levels: the individual dwelling unit, the residential project, the neighborhood, the community, and the region. The City of Gridley promotes energy-efficient building design systems as well as the use of energy saving features and materials during construction through the implementation of state energy conservation requirements.

According to the U.S. Department of Energy, residential energy use accounts for about 22 percent of all energy use nationwide, although homes in the Pacific region, with its milder climate, use up to 35 percent less energy than homes in other parts of the country¹. Energy use includes: 1) space heating and cooling account for 54 percent of residential energy use, 2) water heating accounts for 18 percent, and, 3) lighting accounts for 6 percent. Greater energy efficiency in these three components would contribute to an overall significant reduction in energy use. Statewide, residential uses account for roughly 11% of overall energy use², while the transportation sector accounts for 36%, a large portion of which is related to motor and gasoline diesel use.

Communities that provide for energy conservation for residential buildings and transportation can substantially reduce household and business costs. Monthly utility costs can be reduced through energy conservation techniques, saving on household expenses and increasing housing affordability. According to the Bureau of Labor Statistics' Consumer Expenditure Survey, housing accounts for 35% of spending and utilities and public services associated with housing accounts for 7% of consumer spending.

Table 31
2012 Consumer Spending Categories

Expense Category	% Income Used
Food	12.8
Alcoholic beverages	0.9
Housing	35
Utilities, fuels, and public services	7
Apparel and services	3.4
Transportation	17
Healthcare	6.9
Entertainment	5.1

Source: Bureau of Labor Statistics. Consumer Expenditure Survey, 2009-2012.

¹Source: U.S. Department of Energy at <http://www.eia.gov/totalenergy/data/annual/pdf/aer.pdf>

²Source: U.S. Department of Energy at <http://buildingsdatabook.eren.doe.gov/ChapterIntro2.aspx>

In addition to residential building energy, community design that provides for efficient travel options (short trips, walking, bicycling, public transit) is extremely important to housing affordability and energy conservation. While housing costs represent about 35% of household spending, transportation is the second highest spending category, accounting for 17% of expenses.

In general, opportunities for residential energy conservation include:

- ✓ Compliance with minimum energy conservation standards for residential construction and operations (heating, cooling, cooking, refrigeration, etc.). California requires cities and counties to enforce minimum energy efficiency standards through state building code standards (Title 24 of the California Code of Regulations) and through energy efficiency standards for household appliances.
- ✓ Retrofitting of existing homes that are energy inefficient through weatherization, rehabilitation, and the replacement of older appliances.
- ✓ Energy efficient project site planning that takes maximum advantage of natural systems (sun, shade, wind) for lighting, heating, cooling, and generation of electricity.
- ✓ Neighborhood design and layout that encourage alternatives to automobile use through higher density, mixing of uses, a high degree of transportation connectivity, and street design to encourage all types of mobility.
- ✓ Community and regional growth strategies that emphasize infill development; higher intensity and mixed-use development along transportation corridors.
- ✓ Neighborhood, community, and regional centers with a mix of employment, housing, retail, and services.
- ✓ The placement of housing for a variety of households and income levels as close as possible to job centers and services.
- ✓ Water conservation, water conserving landscaping, and storm water management systems that reduce energy use.

Gridley's approach to energy conservation is intended to strike a balance between up-front energy-saving investments and longer-term cost savings associated with such investments. The city's approach is also keyed to the local climate and priorities of citizens and decision makers for planning and building design. Finally, the city's approach is influenced by several state, regional, and local initiatives and programs. Among the most important initiatives and programs are:

- ✓ State building code standards for energy efficiency (Title 24); and
- ✓ The state's emerging climate change strategies focused on reductions in greenhouse gas emissions, as required by AB 32, the California Global Warming Solutions Act of 2006.

Energy efficiency for new construction

Title 24 of the California Code of Regulations contains California's building standards for energy efficiency. Each city and county must enforce these standards as part of its review of building plans and issuance of building permits. The standards, prepared by the California Energy Commission, were established in 1978 in response to a state legislative mandate to reduce California's energy consumption. The standards are updated periodically to consider and incorporate new energy efficiency technologies and methods. The Energy Commission estimates that California's building efficiency standards, (along with those for energy- efficient appliances, have saved more than \$56 billion in electricity and natural gas costs since 1978. These savings will continue to increase over the next 8 years.

New residential construction is required to meet various standards for energy conservation. As increasing energy demands and limited fuel supplies cause energy prices to rise, households living on a fixed income will be forced to make tough financial decisions regarding household expenses. Since utility costs compete with other household needs, such as food and medicine, energy conservation that results in lower utility bills will provide some relief to low- income households.

Greenbuilding practices

There is a new section within the California Building Code that now includes green building regulations, referred to as CALGreen. This is the nation's first mandatory statewide green building code, intended to encourage more sustainable and environmentally friendly building practices, require low pollution emitting substances that can cause harm to the environment, conserve natural resources, and promote the use of energy-efficient materials and equipment. Gridley will enforce the provisions of CALGreen.

CALGreen Requirements for new residential buildings include:

- Reduce water consumption by 20 percent;
- Divert 50 percent of construction waste from landfills;
- Install low pollutant-emitting materials; and
- Moisture-sensing irrigation systems for larger landscape projects.

Educational outreach programs informing the community can help implement green building measures, for example, providing overhangs on south facing building exposures, use of recycled materials, low VOC paint products, upgrade insulation rated materials, and others that can make new construction and additions to existing structures more energy efficient.

Greenhouse gas emissions reductions

The State of California also adopted the California Global Warming Solutions Act in 2006 (Assembly Bill 32) and declared that "global warming poses a serious threat to the economic well-being, public health, natural resources, and the environment of California." In adopting the act, the Legislature found that human activity is one of the leading contributors to an increase in carbon dioxide, methane, and other "greenhouse gases" (GHGs). The state has declared that these gases are leading to an increase in average global temperatures and contributing to changes in climate throughout the world. The purpose of the act is to reduce GHG emissions to 1990 levels by 2020 (25 percent reduction over

current levels) and then to reduce GHGs to 80 percent below 1990 levels by 2050. Since greenhouse gas emissions are closely tied to energy sources and uses, the implementation of AB 32 will have important ramifications for Gridley's opportunities for energy conservation.

The California Air Resources Board (ARB) is responsible for implementation of AB 32. AB 32 requires the ARB to adopt a quantified cap on GHG emissions representing 1990 emissions levels and disclose how it arrives at the cap; institute a schedule to meet the emissions cap; and develop tracking, reporting, and enforcement mechanisms to ensure that the state achieves the reductions in GHG emissions necessary to meet the cap. AB 32 also includes guidance to institute emissions reductions in an economically efficient manner and conditions to ensure that businesses and consumers are not unfairly affected by the reductions. In October of 2008, ARB published its Climate Change Proposed Scoping Plan (Plan), which is the State's plan to achieve GHG reductions in California required by AB 32 (ARB 2008). The Plan contains the main strategies California will implement to achieve reduction of 169 million metric tons (MMT) of CO₂e, or approximately 30% from the state's projected 2020 emission level of 596 MMT of CO₂e under a business-as-usual scenario (this is a reduction of 42 MMT CO₂e, or almost 10%, from 2002-2004 average emissions).

It also includes ARB-recommended GHG reductions for each emissions sector of the state's GHG inventory. The largest proposed GHG reductions are recommended from improving emission standards for light-duty vehicles (estimated reductions of 31.7 MMT CO₂e), implementation of the Low-Carbon Fuel Standard (15.0 MMT CO₂e, discussed below), energy efficiency measures in buildings and appliances and the widespread development of combined heat and power systems (26.3 MMT CO₂e), and a renewable portfolio standard for electricity production (21.3 MMT CO₂e). It further states that land use planning and urban growth decisions will play an important role in the state's GHG reductions because local governments have primary authority to plan, zone, approve, and permit how land is developed to accommodate population growth and the changing needs of their jurisdictions.

ARB further acknowledges that decisions on how land is used will have large impacts on the GHG emissions that will result from the transportation, housing, industry, forestry, water, agriculture, electricity, and natural gas emission sectors. With regard to land use planning, the Proposed Scoping Plan expects approximately 5.0 MMT CO₂e will be achieved associated with implementation of SB 375. The California Air Pollution Control Officers Association (CAPCOA), which represents local air districts, released a report on ways to measure and reduce GHGs at the local level, including steps that cities and counties can take to contribute to the goals of AB 32. An important local strategy recommended by CAPCOA is the implementation of measures that encourage energy conserving community layout and design. Many of the recommendations are relevant for residential energy conservation and reinforce Title 24 and greenbuilding design. Among the suggestions are:²

- ✓ Promote walkability through a highly connected street system with small blocks;
- ✓ Promote mixed-use neighborhoods centers and transit-oriented development;
- ✓ Reduce the amount of water used for landscaping and encourage the use of recycled water for landscaping;
- ✓ Promote the use of fuel-efficient heating and cooling equipment and other appliances;
- ✓ Encourage green building designs in both new construction and building renovation;

² EDAW | AECOM. Technical Report Components of the CAPCOA Paper, "CEQA and Climate Change," Published by the California Air Pollution Control Officers Association. 2007.

- ✓ Encourage building orientations and landscaping that enhance natural lighting and sun exposure;
- ✓ Encourage the expansion of neighborhood-level products and services and public transit opportunities throughout the area to reduce automobile use;
- ✓ Promote energy-efficient design features, including appropriate site orientation, use of light color, roofing, and building materials;
- ✓ Encourage the development of affordable housing throughout the community, as well as development of housing for elderly and low and moderate income households near public transportation services; and,
- ✓ Ensure that a portion of future residential development is affordable to low- and very low-income households.

Gridley 2030 general plan

Gridley's 2030 General Plan, of which this Housing Element is a part, includes goals, policies, and implementation strategies in several elements that support energy conservation, including, but not limited to those that address:

- ✓ Encourage infill development and development near existing uses.
- ✓ Require efficient use of land through minimizing the amount of land required to meet parking, internal circulation, and delivery/loading needs, shared parking strategies, joint-use of public facilities, and other means.
- ✓ Community design that accommodates walking, bicycling, and transit use.
- ✓ Require strategic land use mixing that places destinations within walking and bicycling distance of homes.
- ✓ Compact development and focusing density/intensity around future planned transit stops.
- ✓ Focus new commercial development to underutilized and vacant properties in the existing Sphere of Influence rather than accommodating new commercial development on the urban fringe, which can increase travel distances.
- ✓ Provide a transportation system that accommodates all locally available travel modes.
- ✓ Require shade trees in parking lots.
- ✓ Increase shade tree canopy Downtown and other public gathering areas and preserve trees in new growth areas to provide immediate shade benefit.
- ✓ Provide incentives for water conservation measures.
- ✓ Expand local generation and use of renewable energy sources for electricity in Gridley and the share of renewable energy in the city's overall portfolio.
- ✓ Require site planning that takes advantage of passive heating opportunities and includes shading for the right portions of new buildings.

Chapter 4: HOUSING NEEDS

The city's share of estimated new housing need is established by the Butte County Association of Governments (BCAG) through the Regional Housing Needs Allocation (RHNA) process for the fifth cycle planning period from January 1, 2014 to June 15, 2022. In addition to the 5th cycle RHNA allocation, the city must accommodate the previous 4th cycle's unmet need. The sites that are available to meet the housing needs consist of vacant, non-vacant, and underutilized developed land that when added together, would be able to meet the development of the number of housing units needed. The capacity used in the analysis considers the existing zoning and utilizes a consideration of "realistic" capacity based on other projects constructed in Gridley. While the city must show how it will provide adequate sites for construction of the required units, it is not obligated to build any of the units itself or finance the construction.

This section also identifies the city's inventory of subsidized housing units that are affordable to lower income households, including identification of housing units "at-risk" of conversion to market rate due to termination of subsidy contracts, mortgage prepayment, or expiration of restrictions on use. Such units include those developed under the US Department of Housing and Urban Development (HUD) programs, tax exempt mortgage revenue bond programs, low-income housing tax credits, redevelopment programs, and density bonus programs.

The analysis includes preservation options for "at-risk" assisted housing developments. Housing needs for special needs groups are detailed in the Community Profile.

Regional housing needs allocation

Butte County Association of Governments (BCAG) received Regional Housing Needs Allocation (RHNA) numbers from the California Department of Housing and Community Development (HCD).¹ The overall numbers provided by HCD are based on projections developed by the California Department of Finance. The income distributions for housing accommodated under the planning period are based on median household incomes for Butte County.

BCAG worked with planning directors from incorporated cities within Butte County along with the County to develop an acceptable methodology for distributing this countywide number among the six jurisdictions in Butte County. The number of very low and low income housing units in comparison to moderate and above- moderate housing units is fairly equally distributed,

According to the Butte County Association of Governments, the city has the responsibility to provide adequately zoned land to accommodate the development of 769 housing units from January 1, 2014 to June 15, 2022, for compliance to the 5th cycle planning period. The RHNA allocations are further defined to accommodate 30 percent of the housing units to very low households, 15 percent to low-income households, 13 percent to moderate income households, and 42 percent to above- moderate income households. The regional housing needs plan does not specify the number of units that are required for the category "Extremely Low Income"; however, this category is assumed to be 50% of the required very low RHNA allocation. **Table 32** provides a numerical value based upon the percentage allocations.

**Table 32
Regional Housing Needs Allocation (2014-2022)**

Income Group	Number of Units	% of Total
Extremely Low ¹	115	15
Very Low	116	15
Low	118	15
Moderate	99	13
Above Moderate	321	42
Total	769	100

Source: BCAG Regional Housing Needs Allocation (RHNA), February 19, 2013.

¹ Extremely low income allocation is assumed to be 50% of total very-low income housing unit need.

The regional target set by BCAG through its Regional Housing Needs Allocation (RHNA) for the 2009-2014 planning period was 1,068 units. The City was able to show available land inventory for 778 housing units. The remaining 290 units anticipated a rezone of land to accommodate the unmet need. The previous housing element demonstrated it had sufficient sites to accommodate 783 units; it contained a rezone program to accommodate the remaining need for lower and moderate income households. The City did not complete the rezoning as described in the housing element program action. Over the previous 5 years, 94 units were constructed leaving an unmet need of 288 units; 91 very low income units, 17 low income units, and 180 moderate income units.

The 4th planning cycle unmet need also must be included in the total number of units the city must be able to provide for the 5th planning cycle. Therefore, pursuant to Chapter 614, Statutes of 2005 (AB 1233) the city must accommodate the unmet need of 288 units as shown below in **Table 33**.

**Table 33
Unaccommodated Housing Need (2009-2014)**

	Very Low	Low Income	Moderate	Above Moderate	Total
RHNA Goal	258	133	182	495	1,068
1) Units Constructed	60	14	2	15	94
2) Previously identified sites currently available (capacity)	107	102	0	480	689
3) Sites rezoned pursuant to Housing Implementation Strategy 2.5	0	0	0	0	0
4) Remaining need	91	17	180	0	288
Total Remaining Need	91	17	180		

Table 35 below combines the required 4th cycle RHNA allocations with the 5th cycle RHNA allocations providing the total number of units that must be accommodated in the 5th cycle planning period of 2014-

2022.

Table 34
RHNA Allocation Total

	Very Low	Low Income	Moderate	Above Moderate	Total
RHNA Unaccommodated Need 2009-2014	91	17	180	0	288
RHNA Allocation 2014-2022	231	118	99	321	769
Total RHNA	322	135	279	321	1,057

The land inventory in Chapter 5, "Housing Resources" provides a list and map of the properties available to meet the RHNA total allocation.

The housing needs of the community also focus on the sunset dates, if any, for assisted housing units that may be "at-risk". Below discusses the existing inventory of assisted units.

Inventory of assisted housing units

The City of Gridley has five housing complexes with a total of 294 dwelling units restricted to lower-income households. **Table 35** provides the number of restricted housing units by development. Of these, two developments, The Oaks and Gridley Springs I, have had conversion dates within the next 10 years however, these have been extended due to RHS 515 funding for rehabilitation. The table also summarizes the characteristics of the two assisted housing developments in the city; "at-risk" these two developments provide 87 units and of those units, 55 specifically serve as elderly housing. These projects are restricted to low-income tenants. The Oaks, completed in 1980, had USDA Rural Rental Housing Section (RHS) 515 financing as did Gridley Spring I built in 1989. Gridley Spring I also received Low Income Housing Tax Credits (LIHTC).

The Oaks and Gridley Springs I were significantly rehabilitated using HOME investment funding mechanisms which secures the conversion of the units for several years.

**Table 35
Assisted Housing Inventory**

Project Name	Location	Type	Funding	Affordability					Earliest Date of Conversion	At-Risk
				Total Assisted Units	Very Low	Low	Moderate	Senior		
Butte County Housing Authority	South Ohio St	Rental	Housing Authority	50		50			No Ending Term Date	No
Hazel Hotel Senior Apartments	880 Hazel St	Rental	LIHTC	14		14		14	2054	No
The Oaks	1500 Hwy 99	Rental	RHS 515	55	55			55	2012	Yes
Gridley Springs I	210 Ford Ave	Rental	RHS 515, LIHTC	32	32				2064	No
Gridley Springs II	200 Ford Ave	Rental	LIHTC	24			24		2046	No
Farm Labor Housing	850 East Gridley Rd	Rental	Housing Authority	112			112		No Ending Term Date	No
Bowwood Subdivision	Bowwood and Little Street	Ownership	RHS 502	6		6			2039	No
Indiana Street		Ownership	CDBG	1			1		2023	No
Total				294	87	70	137	69		87

Sources: The California Housing Partnership; National Housing Trust Data Clearinghouse; Butte County Housing Authority; City of Gridley, 2014; CHIP, 2014

There are several mechanisms that can aid in the preservation of affordable, subsidized housing; transfers of ownership, the purchase of an affordability covenant, and rent subsidy.

Rural development section 515 projects

Under the RHS 515 Program, Rural Development makes direct loans to developers of affordable multi-family rental housing. Interest rates for these programs may be subsidized to as low as one percent. Funds can be used to construct new rental housing complexes, or to repair and rehabilitate existing units. In new RHS 515 projects, 95 percent of tenants must have very low-incomes. In existing projects, 75 percent of tenants must have very low-incomes.

Although these projects are required by law to be listed as “at-risk” of converting to market rate housing, it is not a very good indicator of whether these units will actually convert. The projects “at-risk” under the Section 515 Program do not typically convert to market rate. If a project owner requests to prepay the mortgage, Rural Development provides incentives for the project owners to sign up for additional 20-year loans. If the owner does not accept the financial incentives, Rural Development encourages the owner to sell the property to a non-profit entity to maintain it as affordable housing. Given the incentives in place to preserve Section 515 housing, this housing is generally not considered at risk.

Even with the relatively low likelihood of conversion, the city is pro-active in preventing the loss of affordable housing units. The city committed funds up to \$560,000 to The Oaks and Gridley Springs for rehabilitation; these two at-risk projects continue to remain affordable

Rent subsidy

HUD also administers various affordable housing opportunities for lower income persons, including Section 221 (d) (3), Section 202, Section 236, and Section 811 housing. However, according to the local office of HUD, there are no HUD-administered or subsidized affordable housing complexes or individual units located in the city.

Funding for Section 8 affordable housing originates from the federal Department of Housing and Urban Development (HUD) and Butte County Housing Authority is responsible for administering project-based Section 8 properties.

There are currently 38 households in Gridley that utilize Housing Choice Voucher Assistance (Section 8) to pay the rent. The use of vouchers is not restricted as to the type or location of housing. ,

Preservation options

There are different options available to property owners to preserve the affordability of subsidized housing units.

Transfer of Ownership

Transferring ownership of an at-risk project to a non-profit housing provider is one of the least costly ways to ensure that the at-risk units remain affordable. By transferring property ownership to a non-profit organization, low-income restrictions can be secured indefinitely and the project becomes eligible for a greater range of governmental assistance. Most of these transactions also include rehabilitation of the projects to modernize the property.

Purchase of Affordability Covenant

The provision of an incentive package to owners to maintain affordability of at-risk projects would be another option. Incentives could include writing down interest rates on remaining loan balances in the form of a payment to the project lender and/or supplementing the Homeowner’s Assistance Program (HAP) fair market rent to market levels.

Rental Assistance

The two at-risk projects are funded through the USDA Section 515 Program. None of the projects have Section 8 contracts, but rental assistance to the projects could be structured in a similar fashion to Section 8. The feasibility of this alternative is highly dependent on the availability of funding sources necessary to provide the rental subsidies and the willingness of the owners to accept the subsidies if they are provided. **Table 36** shows the rental subsidies required to preserve the at-risk units. As shown, approximately \$90,072 would be required annually to preserve the current at-risk inventory of 87 units.

Per Unit Affordable Rent (1)	1 BR (2)	2 BR (3)	3BR (4)	Total
Extremely Low Income (30% AMI)	\$309	\$379	\$460	
Very Low Income (50% AMI)	\$514	\$633	\$768	
Low Income (80% AMI)	\$581	\$766	\$1,094	
Average Per Unit Affordable Rent	\$582	\$711	\$849	
Total Fair Market Rent (FMR)*	\$646	\$851	\$1,215	
Monthly Per Unit Subsidy	\$64	\$140	\$364	
Annual Per Unit Subsidy	\$768	\$1,680	\$4,368	
Total “at-risk” Units”	67	18	2	87
Total Annual Subsidy	\$51,456	\$30,240	\$8,376	\$90,072

Source: * FY 2014 HUD Final FMR

Notes:

- (1) Includes total maximum rent and utilities affordable at 30 percent of household income
- (2) Assumes 2-person household
- (3) Assumes 3-person household
- (4) Assumes 5-person household

Replacement costs

Construction of lost units in the affordable housing market is another means of replacement. The cost of developing new housing depends on a variety of factors, including density, unit size, location, land costs, and type of construction. According to the Turner Construction Index, the average construction cost for residential and non-residential development ranges from \$85 per square foot to \$200 per square foot. Based on this national average and an average unit size of 760 square feet, and including land costs, government and other “soft costs”, total replacement costs could be estimated at \$64,600 to \$153,800 per unit. To replace 87 “at-risk” units would range from \$5,620,200 to \$13,380,600 if built today (2014). The cost of index increase averages from 0.8% to 1.24% per year.

Comparison of Preservation Options

Based the different preservation options discussed above related to the existing units in The Oaks and Gridley Springs I, the three cost estimating scenarios indicate the following::

- ✓ Transfer of ownership--\$7,102,767.
- ✓ Rent subsidy--\$92,472 annually or \$1,060,088 over 10 years.²
- ✓ Replacement through new construction--\$ \$5,620,200 to \$13,380,600

While replacement or preservation of 87 “at-risk” units is costly, a transfer of ownership would be the least costly option. Transfer of ownership to a non-profit or government agency also ensures long-term affordability of the units.

Entities Qualified to Preserve At-Risk Units

Organizations in the region with the capacity to own and manage affordable rental projects include the Community Housing Improvement Program (CHIP) and the Housing Authority of Butte County located in Chico as well as the Regional Housing Authority of Sutter and Nevada Counties who can purchase and manage affordable projects. These agencies currently manage affordable rental projects in Gridley.

² Assumes a 3 percent inflation rate per year.

Chapter 5: HOUSING RESOURCES

This section of the Housing Element describes and analyzes those physical, financial and administrative resources that aid the city in providing for the housing needs of its population. Available housing resources are described by a land inventory, preservation of existing units, second unit construction, and downtown mixed use residential/commercial use. **Tables 41 and 41a** provides a list of the city's available land, the use, allowable density, and a total of the number of units in relation to income type to meet the RHNA allocation. These tables also determine if there is adequate infrastructure in place and if there are any environmental constraints. The "Funding and Administrative Resources" section describes available state and federal resources to facilitate the development of housing affordable to special needs groups and lower- income households.

Legal requirements

California law (Government Code Section 65583 (a)(3)) requires that the Housing Element contain "an inventory of land suitable for residential development, including vacant sites and sites having potential for redevelopment, and an analysis of the relationship of zoning and public facilities and services to these sites."

Government Code Section 65583.2(c) requires local government to demonstrate that the projected residential development capacity of the sites identified in the inventory can realistically be achieved. The city must determine whether each site in the inventory can accommodate some portion of its share of the regional housing needs by income level during the planning period. The number of units calculated must be adjusted, as necessary, based on land use controls and site improvement requirements.

Regional housing need allocation (rhna)

The RHNA allocation for the City of Gridley, as described above in Table 35, requires that the city provide housing for the unmet need of the 4th cycle planning period 2009-2014 in addition to the allocation for the 5th cycle 2014-2022 planning period. This results in a total of:

- | | |
|--------------------|-----------------------|
| • 322 units | Very Low Income |
| • 135 units | Low Income |
| • 279 units | Moderate Income |
| • 321 units | Above Moderate Income |
| 1,057 units | Total |

Land inventory

The inventory of land suitable for residential development is provided in Table 41 below. This table also includes two properties that could be available if rezoned or partially developed with housing as well as maintain the current use. Excepting the shaded areas that are a part of the inventory does not create an unmet need. Pursuant to the requirements, the land inventory addresses the general plan and zoning designations, infrastructure availability and identifies any environmental concerns that there might be. None are known at the time of the preparation of this information, therefore, based upon the evaluation of the sites, housing development to meet the RHNA allocation is determined feasible and the table illustrates there is sufficient land to meet the housing need. .

Units Built

Cities and Counties may use units that have been built from January, 2014 towards fulfillment of the RHNA allocation. The City has issued building permits, however, they are a part of the two subdivisions that are currently being built out and therefore no units are described herein.

Units in Progress

Table 37 lists approved housing as of the writing of this document. Completion of these projects will provide moderate and above-moderate income housing units. These subdivisions are listed and counted in the land inventory.

Table 37									
Units Under Construction or Approved									
Name	Type	Funding	Total	Income					Status
				AM	M	L	VL	EL	
Steffan Estates	Single family	Private	28	28					Approved
Edler Estates	Single family	Private	25	25					Approved
Heron Landing	Single family	Private	32	32					Under construction
Eagle Meadows	Single family	Private	78	78					Under construction
Total			163	163					

Land inventory

The land inventory could accommodate 678 lower-income units, Table 41, and 828 above moderate-income units, Table 41a. The available units on line items 3 and 4 of Table 41 could be excepted. They are listed because they represent an opportunity to provide affordable or special needs housing, line item 3, which is proximate to “The Orchard Hospital”. Line item 4 is currently developed with a church. At the north side of this parcel there is approximately a 0.5 acre area that could be developed for special needs housing related to their church. If the two parcels are excepted from the calculation, there would still be enough land area to accommodate the very low, and low income affordable housing levels.

The city has updated the vacant parcel inventory in preparation of the Housing Element Update. This has been accomplished by reviewing the most recent parcel/assessor land use codes, querying permit data, conducting site visits, and reviewing updated aerial photography to determine the validity of vacant parcels. All of the sites inventoried can be served by City services; infrastructure is in place or in close proximity. The zoning designations for the sites include:

R-S	Residential Suburban	3 du/ac
R-1	Single Family Residential	4 du/ac
R-2	Duplex Residential	8 du/ac
R-3	Multiple Family Residential	15 du/ac
C-1	Restricted Commercial	#/use permit
C-2	General Commercial	#/use permit
M-1	Light Industrial	#/use permit

Based on recent projects the city has assumed the allowable densities in accordance with the Title 17 of the Gridley Municipal Code and have also adjusted the density to conform to the surrounding area or provide a realistic capacity whereby the allowable density would be infeasible.

Realistic Capacity

Government Code Section 65583.2(c) requires, as part of the analysis of available sites, a local government to demonstrate the projected residential development capacity of the sites identified in the housing element can realistically be achieved. Based on the information provided in subdivision (b), a city or county shall determine whether each site in the inventory can accommodate some portion of its share of the regional housing need by income level during the planning period, as determined pursuant to Section 65584. The number of units calculated shall be adjusted as necessary, based on the land use controls and site improvements requirement identified in paragraph (4) of subdivision (a) of Section 65583.

To identify the sites and establish the number of units that can accommodate the local government's share of the regional housing need for lower-income households, the element must include an analysis that demonstrates the identified zone and densities which encourage and facilitate the development of housing for lower-income households. To provide local governments with greater certainty and clarity in evaluating and determining what densities facilitate the development of housing affordable to lower-income households, the statute provides two options; the analysis must, at a minimum, describe the following:

1. market demand and trends;
2. financial feasibility; and
3. information based on residential project experience within a zone(s) where the densities facilitated the development of housing for lower-income households, or,

the default density must be used. The state has established that Butte County has a default density of 20 du/ac to meet the required number of affordable housing units. The City of Gridley believes that based upon the success of previous projects that have used lower densities, these have been financially successful at the time of completion and continue to be so today.

Information gathered from local developers, and examples of recent residential projects that provide housing for lower-income households has been supports the appropriateness of the zoned and reduced densities from the default density. It is recognized that housing affordable to lower income households requires significant subsidies and financial assistance. However, for the purpose of the adequate sites analysis and the appropriateness of zoning, identifying examples of lower density subsidized housing projects alone is provided that have been constructed in Gridley as well as other "suburban/rural" communities such as Live Oak and Yuba City located in Sutter County. The feasibility of lower affordable housing densities is directly related to the reduced land costs found in more rural areas such as

Butte County and Sutter County, therefore reducing the overall pro forma of a project. Discussions with local developers also concur.

The R-3 zone has a maximum density of 15 units per acre and is currently the highest- density zoning district in the city. This is the primary residential zone for development of apartments and other types of housing that is affordable to lower- and moderate-income households. All of the apartment complexes affordable to lower-income households, including the Oaks and Gridley Springs I and II, are located in the R-3 zoning district, however, these have been built with lower densities. Other single-family affordable housing developments are located throughout the City in even lower-density residential zones, such as R-1 and R-2 as well as R-S districts, which allow 4 and 3 du/ac, respectively. These affordable developments have been constructed in the previous planning period as CHIP sweat equity developments that are sold to low income level families. The Housing Implementation Strategy will include flexibility for the R-3 density to increase to match the default density to ensure affordability is maintained if needed.

Recent affordable projects have been constructed at densities ranging from approximately 3 to more than 12 (12.73) units per acre with subsidies. **Table 38** summarizes recent affordable single family and multifamily housing projects constructed and the financing used for these projects.

Table 38
Examples of Affordable Housing Projects Less Than 20 Du/Acre

Name	Type	Total Units	Mod	Low	VLI	Acres	Density	Zoning
Locust Estate*	Single family	13	-	13	-	3.55	3.7	R-S
Washington Court **	Multi-family	56	-	27	29	4.46	12.78	R-3

Source: City of Gridley, CHIP

Subsidy Amounts of Affordable Housing Projects Less Than 20 Du/Acre

Name	Fund	Type	Amount
Locust Estate	Federal Home Loan Bank	Federal	\$150,000
	USDA-RD Section 502	Federal	Amount varies; homebuyers eligible for 1% fixed interest rate mortgage loan
	Prop 1C Joe Serna Jr. Farmworker Housing Grant	State	\$660,000
Washington Court	LIHTC	Federal	\$11,777,990
	LIHTC	State	\$3,925,995
	Cal-HOME	State	\$1,900,000
	Gridley Redevelopment Agency	City	\$400,000

The recently approved project, Washington Court Apartments, provides affordable housing at 12.78 units per acre. The project approval process included a market study, assessment of construction costs, and a pro-forma analysis showing the feasibility of this project at a density of less than 13 units per acre. The Washington Court project has identified a construction loan, HOME Funds, and equity investment equal to the total construction costs (including contingencies and developer profit). The analysis conducted to support this project identifies the total operating budget of the project (including reserves). Washington Court's revenues are shown to provide for operating expenses and meeting debt service obligations. The Primary Market Area used in the market study prepared to support the Washington Court project is the City of Gridley and the secondary market is Butte County. The market study identifies current demand for 123 units of two- and three-bedroom units in the City of Gridley and as noted, the project provides 56 units. For the Washington Court project, land costs were just 4.5% of the total development costs.

To further ensure that affordability can be delivered at less than 20 units per acre, the City collected information on another affordable housing project in the neighboring community of Live Oak that was developed at a density of 12.73 units per acre. This project, Maple Park, is a 56 unit, multi-family reconstruction project that will provide 26 two-bedroom units, 28 three-bedroom units and 2 four-bedroom units for households earning 30 to 60% of the area median income (AMI). As with the Washington Court project, Maple Park involved an analysis of construction costs against sources of revenue and financing to ensure the feasibility of the project. The Maple Park project has identified a construction loan, HOME Funds, CDBG Funds, loan from the Federal Home Loan Bank, and equity investment equal to the total construction costs (including contingencies and relocation assistance). The analysis shows adequate cash flow for operations and meeting debt service obligations. The Primary Market Area used in the market study prepared to support the Maple Park project is City of Live Oak, the City of Gridley, the northwest portion of the City of Yuba City and surrounding unincorporated Sutter County. The market study identifies sufficient demand in the area for this project.

City staff also collected information from the City of Oroville regarding a recently constructed project by the same developer that will develop Gridley's Washington Court project. This project, Hillview Ridge Apartments, was opened in December of 2008. Hillview Ridge identified a construction loan, HOME Funds, a Redevelopment Agency loan, and tax credit for construction and operational costs (including reserves). This project involved a pro-forma analysis that shows positive cash flow for the Hillview Ridge project, with land costs representing just 5.75% of the total development costs. Hillview ridge has 72 units and was developed at a density of approximately 8-10 units per acre.

Based on these three specific examples, in addition to other information available to the City, it is clear that with low-interest loans, tax credits, and other commonly available tools, delivering affordable housing is feasible in Gridley at densities of less than 20 units per acre. In the case of the Gridley and Live Oak projects, densities of 12-13 units per acre have been shown to provide this opportunity. The difference between this density level and the "default" density assumed to provide for lower-income housing likely rests primarily with land costs. As noted above, projects before and after the recent downturn in the real estate market had land cost that represented approximately 5% of the total development costs. With lower land costs in this part of the region compared to other areas, it has been thoroughly demonstrated that densities of 20 units per acre are not necessary to produce affordable housing. It is unlikely that there would be such a quick and drastic escalation in land costs that the City's assumptions in this respect would change during this housing element planning period.

To further illustrate the local context relative to land costs and affordability at lower densities, the City surveyed 100 unimproved multi-family properties currently for sale around the state. The median

per-acre cost for the properties in this survey was \$234,177. This compares to a per-acre land cost for the Washington Court project of \$146,000 – approximately 38% lower than the comparison community multifamily land costs. While, by necessity, this is a snapshot analysis, it is clear that land costs are relatively low in the Gridley area. With the analysis conducted by the City to support this Housing Element, as summarized above, the City has demonstrated that the current R-3 zone provides the opportunity for lower-income housing.

Non-residential Zoning Districts that Allow Multi-Family Housing

In addition to the sites shown above with residential zoning designations, the Zoning Ordinance allows for the development of residential dwellings in commercial zones (C-1, C-2), subject to a conditional use permit (CUP). The City's conditional use permit process has not historically presented problems in terms of processing time or expense. However, to fully ensure against this theoretical constraint, the City has drafted Housing Implementation Strategy 3.2 to address the CUP process and ensure it is not a constraint to higher- density, mixed-use development (see the Housing Plan section). This strategy is being carried forward to amend as necessary to ensure there is no constraint for development in the commercial zoning district. The land inventory includes appropriate parcels with C-1 or C-2 zoning. There is no minimum lot size for the C-2 or C-1 zone. The maximum building height is 50 feet. For the C-1 zone, the maximum lot coverage is 100% and for the C-2 zone, maximum lot coverage is 90%. Under the City's zoning and development standards, an additional 153 lower-income units could be developed on sites with commercial zoning. There are no other substantially constraining land use controls or applicable development standards.

The City's history of affordable multi-family development in non-residential zoning districts includes the Washington Court project, which originally had M-1 zoning. The Hazel Hotel project provides 14 assisted units for low-income tenants. This project was developed in the C-1 zone and involved renovation of an existing hotel building to provide affordable senior housing. The parcel involved is approximately 0.35 acres and therefore the residential density is approximately 40 units per acre.

The Zoning Ordinance does not limit density in commercial zones. Past residential projects in commercial zones have followed the development standards and densities established for R-3 (Multi-family Residential) zone. For the purposes of this land inventory, it is assumed that, collectively, half of the commercial sites could be developed at a density of 15 units per acre, removing 20 percent of the land for roadways and other undevelopable areas. However, since the Zoning Ordinance does not actually have a specific limit on density for multi-family housing in these zones, the actual density for housing development on these sites could be somewhat higher than the conservative estimates of capacity used in this Housing Element.

The Housing Plan will commit the City to identify and consider implementing a range of incentives to encourage development of vacant and underutilized properties.

Table 39
Potential Residential Land Inventory and Zoning Designations related to E/VL/L Affordability

Site No.	Assessor's Parcel Number	Existing General Plan	Zoning	Allowable Density	Parcel Acreage	Unit Capacity	Existing Use	Location	Income	Infrastructure Capacity	Environmental Constraints
1	010-200-041	C	C-2	8	1.05	8	Vacant	Hwy 99 S. Cherry St.	EL/VL/L	Yes	No
2	010-240-034	C	C-2	8	1.67	13	Vacant/Business Parking	Hwy 99 x Vista Del Rio	EL/VL/L	Yes	No
3	010-250-026	P	PQP ¹	15	5	60*	Vacant	Ford Ave	EL/VL/L	Yes	No
4	010-250-014	C	C-1	6*	1.5	6	Church (0.5 ac to north available)	Ford Ave	EL/VL/L	Yes	No
5	010-250-030	RHD	R-3	15	1.09	12*	Vacant	Ford Ave	EL/VL/L	Yes	No
6	010-250-031	RHD	R-3	15	1.09	12*	Vacant	Ford Ave	EL/VL/L	Yes	No
7	021-240-025	I	M-1**	20	15	300	Vacant	Ptn of 23.64ac/Hwy 99	EL/VL/L	Yes	No
8	024-020-007	RMD	R-2	8	3.36	26	Vacant	Hwy 99 S Morrison Slough	EL/VL/L	Yes	No
9	024-020-008	RMD	R-2	8	5.43	43	Vacant	Hwy 99 S Morrison Slough	EL/VL/L	Yes	No
10	024-070-036	C	C-2	12*	1.05	12	Vacant	Hwy 99 S. Obermeyer	EL/VL/L	Yes	No
11	024-260-044	C	C-2**	10	17.32	150	Vacant	Hwy 99 x Gridley Biggs Rd	EL/VL/L	Yes	No
12	024-260-079	RHD	R-3*	15	1.98	24	Vacant SFR; not in use	Hwy 99	EL/VL/L	Yes	No
13	024-270-004	C	C-2	8	1.62	12	Vacant; Ag use-orchard	Hwy 99 N. Sheldon Ave	EL/VL/L	Yes	No
Total number of unit capacity for moderate and above moderate income housing						678					
Total number of units required per RHNA for extremely low, very low, and low income housing						<457>					
Excess buildable unit capacity						221					

Shaded parcels are reflected as a future opportunity if needed. The required number of extremely low, very low, and low residential units are met without using them. They are included as partially-vacant, or vacant sites that could be developed in the future.

¹ Site would need to be rezoned from PQP to R-3

* Represents realistic capacity at 12 du/ac based on the location of the parcel

** Requires a conditional use permit

*** The deficit for moderate and above moderate income units is met utilizing Units approved or under construction depicting the number of lots available

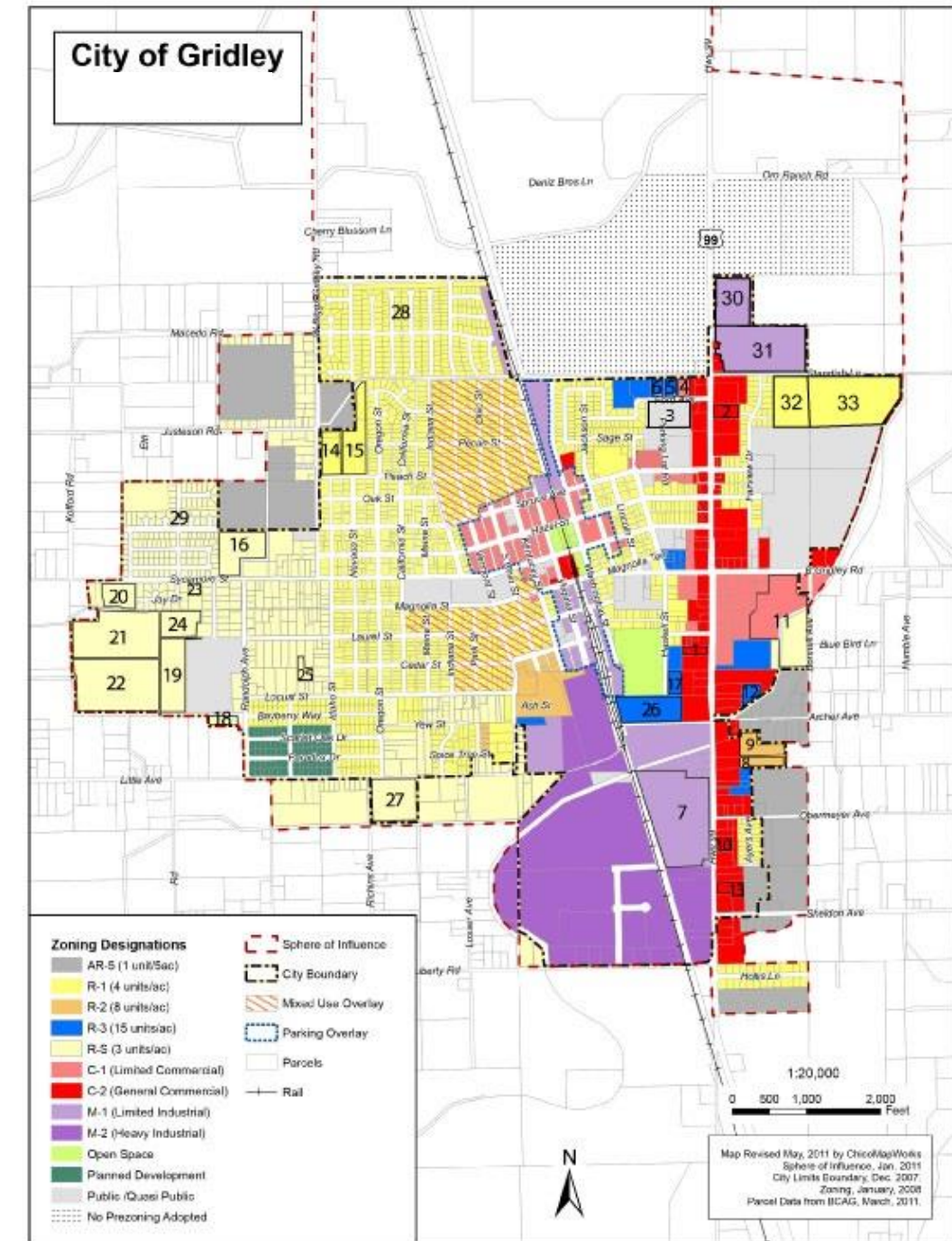

Table 40
Potential Residential Land Inventory and Zoning Designations related to M/AM Affordability

Site No.	Assessor's Parcel Number	Existing General Plan	Zoning	Allowable Density	Parcel Acreage	Unit Capacity	Existing Use	Location	Income	Infrastructure Capacity	Environmental Constraints
14	009-260-022,-024,-025	RLD	R-1	4	3.94	15	Vacant	Valley Oaks Ests	M/AM	Yes	No
15	009-260-026,-027,-028,-029	RLD	R-1	4	7.36	29	Vacant	Pecan St	M/AM	Yes	No
16	009-290-066	RVLD	R-S	3	10.2	31	Vacant	Sycamore St	M/AM	Yes	No
17	010-200-043	RHD	R-3	15	1.48	22	Vacant	Haskell St/Qumar Est	M/AM	Yes	No
18	010-270-051	RVLD	R-S	3	1.34	4	Vacant	W of Bayberry St	M/AM	Yes	No
19	010-270-076	RVLD	R-S	3	8.41	25	Vacant	Elder Ests/Laurel St	M/AM	Yes	No
20	010-270-120	RVLD	R-S	3	4.4	13	Vacant	Dusa Ests Dev.	M/AM	Yes	No
21	010-270-121	RVLD	R-S	3	16.63	50	Vacant	Butte Country Homes Unit 1	M/AM	Yes	No
22	010-270-122	RVLD	R-S	3	19.51	70	Vacant	Butte Country Homes Unit 2	M/AM	Yes	No
23	010-290-002	RLD	R-1	3	0.78	3	Vacant	Sycamore St	M/AM	Yes	No
24	010-290-041	RVLD	R-S	3	4.42	13	Vacant	W of Laurel St	M/AM	Yes	No
25	010-310-057	RVLD	R-S	3	1.32	4	Vacant	Laurel x Cedar	M/AM	Yes	No
26	021-110-039	RHD	R-3	15	6	90	Vacant	Btw Haskell x Hwy 99	M/AM	Yes	No
27	021-250-008	RVLD	R-S	3	8.81	28	Vacant	Steffan Ests Dev	M/AM	Yes	No
28	Multiple lots	RLD	R-1	4	n/a	32	Vacant	Heron Landing	M/AM	Yes	No
29	Multiple lots	RLD	R-1	4	n/a	78	Vacant	Eagle Meadows	M/AM	Yes	No
30	025-200-118	I	M-1**	8	9.81	78	Vacant	Hwy 99, east side	M/AM	Yes	No
31	025-260-008	I	M-1**	8	17.54	140	Vacant	Hwy 99 east side	M/AM	Yes	No
32	025-200-053	RLD	R-1	4	7.46	29.84	Vacant/Sport field	Hwy 99 east side	M/AM	Yes	No
33	025-*200-054	RLD	R-1	4	18.5	74	Vacant/Sport field	Hwy 99 east side	M/AM	Yes	No
Total number of unit capacity for moderate and above moderate income housing						828					
Total number of units required per RHNA for housing moderate and above moderate housing						<600>					
Excess buildable unit capacity						228					

* Represents realistic capacity at 12 du/ac based on the location of the parcel

** Requires a conditional use permit

*** The deficit for moderate and above moderate income units is met utilizing Units approved or under construction depicting the number of lots available

Funding and administrative resources

The City of Gridley has access to a variety of existing and potential funding sources for affordable housing activities. This section offers a summary of funding sources which are currently used by the City, as well as additional funding sources which are potentially available to support various programs.

Affordable development

On June 29, 2011, the primary subsidy for affordable housing disappeared almost overnight due to the abolishment of redevelopment agencies due to State budget shortfalls. On December 29, 2011 the California Supreme Court released its decision in *California Revelopment Association et. al. v. Matosantos*. In what represented the worst case scenario for redevelopment agencies, the Court upheld the legislation abolishing redevelopment agencies. It also invalidated a companion bill that gave redevelopment agencies the opportunity to continue in existence by remitting tax increment monies to the state. California had one of the most aggressive redevelopment programs in the nation, with a minimum of 20 percent of tax increment financing funds earmarked for affordable housing. Arizona is the only other state in the U.S. that does not use redevelopment agencies to provide affordable housing projects. The poverty rate in California is among the highest in the nation, and the need for affordable housing will only grow more acute. The state's population is expected to increase by an average of 400,000 per year, with the largest growth occurring in minority and immigrant communities that tend to need affordable housing the most.

The City of Gridley is leveraging its available revenues with other funding mechanisms to support affordable housing projects such as HOME investment partnership program loan products, CDBG funding and others to support developers as they come forward to invest in the community. The City will continue to maximize the opportunity for the development of affordable housing projects by packaging funding mechanisms noted with other State and Federal funds that become available.

The city has established the Housing Fund be used along with the First-Time Homebuyer Program (FTHB) and/or an Affordable Housing Development Assistance (AHDA) Program and working together with the Regional Housing Authority of Sutter and Nevada Counties to advertise to qualifying applicants. Due to limited fund reserves, implementation of these programs are based on the availability of funds that can be used.

Low- and Moderate-Income Housing

In the five years since the adoption of the 2009-2014 Housing Element, 56 units in the Washington Court Apartments were constructed for very low- and low-income households. Additionally, sweat equity CHIP housing was constructed and significant restoration and preservation of units were completed which included those in “The Oaks” and “Gridley Springs I and II”. Funding for additional preservation and or new construction of affordable units will be supported in the new planning period. The City continues to look for opportunities to increase the number of affordable homes.

State and federal resources

In addition to the funding programs available through the City and County, there are several State and Federal funding programs that assist first-time homebuyers, build affordable housing, and help special needs groups, such as seniors and large households. In most cases other entities, including for-profit and non-profit developers, apply for funds or other program benefits. For example, developers apply directly to USDA for Section 515 loans, to HUD for Section 202 and Section 811 loans, or to the California Tax Credit Allocation Committee (CTCAC) for low-income housing tax credits.

Table 41 below summarizes several of the State and Federal funding programs that are available to fund affordable housing opportunities.

The City has approved a contract with the Regional Housing Authority of Sutter and Nevada Counties to assist the city in managing Community Development Block Grant (CDBG) and Home Investment Partnership Program (HOME) grants. The City routinely tracks grant funding opportunities and prepares applications, as appropriate, for housing-related, as well as other community objectives.

The City of Gridley has access to several Federal, State and local resources to achieve its housing and community development goals. Specific sources will be utilized based on the eligibility and requirements of each project or program, described below:

Community Development Block Grants (CDBG). The Department of Housing and Urban Development (HUD) awards CDBG funds annually to entitlement jurisdictions and States for general activities, including housing and economic development activities. CDBG funds designated for housing primarily support rehabilitation and provide funds for the purchase, construction or improvement of single-family and multifamily housing.

Housing Choice Voucher (Section 8). HUD provides funds to local public housing agencies to administer the Housing Choice Voucher program. Qualified families are eligible to receive tenant-based rental subsidies. The tenant's portion of the rent is based on 30 percent of the adjusted family gross income. The Housing Authority subsidizes the difference between the tenant's portion and the contract rent. However, Fair Market Rents (FMR) restricts the actual contract rent as determined by HUD.

Home Investment Partnership Program (HOME). HOME funds are awarded annually as formula grants to participating jurisdictions. HUD establishes Home Investment Trust Funds for each grantee, providing a line of credit that the jurisdiction may draw upon as needed. HOME funds can be used for the new construction and rehabilitation of affordable housing, covering both homeownership and rental properties. Funds can also be used to support homeownership programs, as “gap” loans for multifamily rental development and rehabilitation.

Rural Development Grants. The Rural Development Housing and Community Facilities Program of the US Department of Agriculture (USDA) offers grants and direct and guaranteed loans for farm worker, low- and very-low income housing. Funds can be used to support a range of activities including reparation and rehabilitation of single- and multi-family housing, construction of farmworker housing, assistance for home-buyers and direct loans for the purchase and improvement of land for residential construction. Funds are awarded on a competitive basis to eligible individuals, public agencies, nonprofit and for-profit developers.

Mortgage Revenue Bonds. Tax-exempt mortgage revenue bonds can be issued by the City for housing developments that restrict a portion of their units for very low income and low income households. The basic federal requirements are that 20 percent of the units must be restricted to very low income households (50 percent of area median income), or 40 percent of the units restricted to households at 60 percent of area median income. The funds raised as a result of the bond sales carry below market interest rates, but these favorable terms are often not sufficient to produce a feasible mixed income development.

Under these conditions, developers may couple their bond applications with Low Income Housing Tax Credits to raise the equity needed for the project's affordability and feasibility. Bond-funded developments with tax credits may have a longer affordability period (55 years) than the 30-year regulatory term on a project with bonds alone.

Mortgage Credit Certificates (MCC). The MCC program provides financial assistance to first time homebuyers for the purchase of new or existing single-family homes. The MCC provides qualified first time homebuyers with a federal income tax credit. Income tax credits reduce an individual's tax payment(s) by an amount equal to the credit. The MCC program can be used to increase homeownership.

Proposition 1C Funding. Proposition 1C authorized about \$2.85 billion in State funding for a variety of housing programs. Potential uses of Proposition 1C funds include brownfield cleanup and infill incentives, multifamily housing programs, implementation of Transit Oriented Development (TOD), the state's Homeowner Down-payment Assistance program, supportive housing, farmworker housing, emergency housing assistance, and programs for homeless youth. Proposition 1C funds in the amount of \$660,000 were awarded to the Community Housing Improvement Program towards the development of Locust Estate.

Multifamily Housing Program (MHP). HCD conducts the acquisition and rehabilitation component of the MHP to assist the new construction, rehabilitation, and preservation of permanent and transitional

rental housing for lower income households. Special allocations have been made for supportive housing with associated health and social services for low income renters with disabilities, or individuals or households that are moving from emergency shelters or transitional housing, or are “at-risk” of homelessness. MHP can be used by local governments, for-profit and nonprofit corporations, limited equity housing cooperatives, and individuals to construct, rehabilitate, or preserve permanent and transitional rental housing.

Affordable Housing Innovation Program (AHIP). AHIP funds the creation of pilot programs to demonstrate innovative, cost-saving approaches to creating or preserving affordable housing through grants and loans.

Building Equity and Growth in Neighborhoods (BEGIN). BEGIN funding includes grants to local public agencies to make deferred-payment second mortgage loans to qualified buyers of new homes, including manufactured homes on permanent foundations, in projects with affordability enhanced by local regulatory incentives or barrier reductions. These grants are used to increase homeownership among low- and moderate income residents.

CalHOME. CalHOME funding includes grants to local public agencies and nonprofit corporations to assist individual households through deferred-payment loans, as well as direct, forgivable loans to assist development projects involving multiple ownership units, including single-family subdivisions. These grants are used to enable low- and very low income residents to become or remain homeowners.

CalHOME Self-Help Housing Technical Assistance Allocation. CalHOME Self-Help funding includes grants to local public agencies and nonprofit corporations for programs that assist low and moderate income families to build their homes with their own labor. These grants are used to increase homeownership and asset-building among low- and moderate income residents.

Emergency Housing Assistance Program (EHAP). EHAP funding includes both operating grants and deferred loans for capital development. Grants can be used for facility operations of emergency shelters, transitional housing projects, and supported services for homeless individuals and families. Loans to local public agencies and nonprofit developers may be used for capital development activities for emergency shelters, transitional housing and safe havens that provide shelter and supportive services for homeless individuals and families.

Predevelopment Loan Program (PDLP). PDLP funding includes short term loans to provide capital to finance the start of low income housing projects. These loans can fund redevelopment costs of projects to construct, rehabilitate, convert or preserve assisted housing, including manufactured housing and mobile home parks.

Workforce Housing Reward Program. This program provides financial incentives to cities and counties that issue building permits for new housing affordable to very low or low income households. Grants can be used for construction or acquisition of capital assets.

Institutional resources

The city works with public and private sector organizations involved with the development of affordable housing. These agencies are involved in the improvement of the housing stock, expansion of affordable

housing opportunities, preservation of existing affordable housing, and/or provision of housing assistance to households in need. Agencies with current or recent affordable housing projects in Gridley include the following:

Housing Authority of the County of Butte (HACB). The HACB, located in the City of Chico, manages housing and community development activities including low rent public housing, the HUD Housing Choice Voucher (Section 8) program, the USDA Farm Labor Program. The mission of HACB is to assist low and moderate income residents of Butte County to secure and maintain high quality affordable housing. Subsidized housing is provided to families, seniors and disabled individuals whose income is between 50% and 80% of median area income. Open Market housing is available to all applicants at affordable rents.

Regional Housing Authority of Sutter and Nevada Counties. The RHASN, located in the City of Yuba City, manages programs specifically targeted to affordable home ownership and rental programs. They liaison with ownership entities and partner to manage project sites for small communities.

Community Housing Improvement Program (CHIP). CHIP currently serves 11 counties in California's north central valley, including Butte County. CHIP is involved in a number of housing development and rehabilitation activities, including development of self-help, single-family and multi-family housing, provision of housing and credit counseling services, property management and residential land development.

The following **Table 41** lists the various state and federal funding programs available for affordable housing projects.

TABLE 41
Federal and State Financial Resources for Housing

Program Name	Program Description
Federal Programs	
Community Development Block Grant (CDBG)	Provides grants for acquisition, rehabilitation, home buyer assistance, economic development, homeless assistance, and public services
HOME	Provides grants to jurisdictions on a competitive basis for acquisition, rehabilitation, home buyer assistance, and rental assistance
Home Ownership for People Everywhere (HOPE)	HOPE program provides grants to low income people to achieve homeownership. The three programs are: HOPE I—Public Housing Homeownership Program HOPE II—Homeownership of Multifamily Units Program HOPE III—Homeownership for Single-family Homes
Housing Opportunities for Persons with AIDS (HOPWA)	Funds are made available countywide for supportive social services, affordable housing development, and rental assistance to persons with HIV/AIDS.
Low Income Housing Tax Credits (LIHTC)	Provides Federal and state income tax credits to persons and corporations that invest in low-income rental housing projects.
Mortgage Credit Certificate (MCC) Program	Provides income tax credits to first-time homebuyers to buy new or existing homes.
Federal Emergency Shelter Grant Program (FESG)	Provides grants to jurisdictions to implement a broad range of activities that serve the homeless. Eligible activities include shelter construction, shelter operation, social services, and homeless prevention.
Section 8 Housing Choice Rental Voucher Program	Provides financial assistance to public housing authorities to fund rental assistance payments to owners of private market rate units on behalf of very low-income tenants.
Section 108 Loan Guarantee	Provides loan guarantees to CDBG entitlement jurisdictions for capital improvement projects that benefit low- and moderate-income persons, or aid in the prevention of slums. Maximum loan amount can be up to five times the jurisdiction's recent annual allocation. Maximum loan term is 20 years. Eligible activities include acquisition, rehabilitation, home buyer assistance, economic development, homeless assistance, and public services.
Section 202	Provides an interest-free capital advance to cover the costs of construction, rehabilitation, or acquisition of very low-income senior housing. The sponsor does not have to repay the capital advance as long as the project serves the target population for 40 years. Rental assistance funds are provided for three years, and are renewable based on the availability of funds. The program is available to private, non-profit sponsors. Public sponsors are not eligible for the program.
Section 811	Provides an interest-free capital advance to cover the costs of construction, rehabilitation, or acquisition of housing for persons with disabilities. The sponsor does not have to repay the capital advance as long as the project serves the target population for 40 years. Rental assistance funds are provided for three years, and are renewable based on the availability of funds. The program is available to private, non-profit sponsors. Public sponsors are not eligible for the program.
Shelter Plus Care Program (S+C)	Provides rental assistance for hard-to-serve homeless persons with disabilities in connection with supportive services funded from sources outside the program.
Supportive Housing Program	Provides funding for transitional housing and supportive services for homeless persons.
U.S. Department of Agriculture (USDA) Housing Programs (Section 514/516)	Provides grants for construction, rehabilitation, or acquisition of capital assets in designated Catalyst Communities.

State Programs

Affordable Housing Innovation Program– Catalyst Community Grant Program	Provides grants for construction, rehabilitation, or acquisition of capital assets in designated Catalyst Communities.
Affordable Housing Innovation Program– Golden State Acquisition Level	Provides quick acquisition financing for the development or preservation of affordable housing. Loans with terms up to 5 years are provided to housing sponsors and developers through a nonprofit fund manager.
Affordable Housing Innovation Program – Local Housing Trust Fund	Provides matching grants (dollar-for-dollar) to local housing trust funds that are funded on an ongoing basis from private contributions or public sources (that are not otherwise restricted). The grants may be used to provide loans for construction of rental housing that is deed-restricted for at least 55 years to very low-income households, and for down-payment assistance to qualified first-time homebuyers.
Building Equity and Growth in Neighborhoods (BEGIN)	A homeownership program that provides grants to local governments that reduce regulatory constraints to housing. The grants are used for down-payment assistance, in the form of a low-interest loan, to low- and moderate-income first-time homebuyers.
CalHOME	Provides grants to local governments and non-profit agencies for local home buyer assistance and owner-occupied rehabilitation programs and new development projects. Funds can be used to finance the acquisition, rehabilitation, and replacement of manufactured homes.
California Self-Help Housing Program (CSHHP)	Provides grants for sponsor organizations that provide technical assistance for low- and moderate- income families to build their homes with their own labor.
Disaster Recovery Initiative (DRI) / Disaster Recovery Enhancement Fund (DREF)	Provides grants for the construction, acquisition, rehabilitation, and preservation of affordable rental and ownership housing, homeless shelters and transitional housing; public services; public facilities and infrastructure projects for the primary benefit of low- and moderate-income persons; where applicable, the development or retention of jobs for lower-income workers; and forward thinking hazard mitigation planning activities.
Emergency Housing and Assistance Program Capital Development (EHAPCD)	Provides grants and loans to support emergency housing. Two types of assistance are available: 1) deferred payment loans for capital development activities; and 2) grants for facility operating costs.
Emergency Solutions Grants Program	Provides grants to fund projects that serve homeless individuals and families with supportive services, emergency shelter, and transitional housing; assist persons at risk of becoming homeless with homelessness prevention assistance; and provide permanent housing to the homeless.
Governor’s Homeless Initiative (GHI)	Provides deferred payment permanent loans through HCD’s Multifamily Housing Program (MHP-SH); construction, bridge and permanent loans from the California Housing Finance Agency (CalHFA); and grants for rental assistance from the Department of Mental Health (DMH) to fund new construction, rehabilitation, acquisition, and rehabilitation of permanent rental housing, and conversion of nonresidential structures to rental housing.
HOME Investment Partnerships Program (HOME)	Provides grants to municipalities that do not receive HOME funds from HUD for the rehabilitation, new construction, and acquisition and rehabilitation of single family and multifamily housing projects; first- time homebuyer mortgage assistance; owner-occupied rehabilitation; and tenant-based rental assistance programs.
Housing-Related Parks Program	Provides grants for the creation of new parks or the rehabilitation and improvement of existing parks and recreational facilities.
Infill Infrastructure Grant Program (IIG)	Provides grants to assist in the new construction and rehabilitation of infrastructure that supports higher- density affordable and mixed-income housing in locations designated as infill.
Joe Serna, Jr. Farmworker Housing Grant Program	Provides matching grants and loans for the acquisition, development, and financing of ownership and rental housing for farmworkers.
Mobile Home Park Resident Ownership Program (MPROP)	Provides loans to mobile home park resident organizations, non-profit entities, and local public agencies to finance the preservation of affordable mobile home parks

	by conversion to ownership control.
Multifamily Housing Program (MHP)	Deferred payment loans for the new construction, rehabilitation, and preservation of rental housing, supportive housing, and housing for homeless youth.
Office of Migrant Services (OMS)	Provides grants to local government agencies that contract with HCD to operate OMS centers located throughout the state for the construction, rehabilitation, maintenance, and operation of seasonal rental housing for migrant farmworkers.
Predevelopment Loan Program (PDLP)	Provides short-term predevelopment loans to finance the start of low-income housing projects.
State Community Development Block Grant Program (CDBG)	Provides grants to fund housing activities, public works, community facilities, public service projects, planning and evaluation studies, and economic assistance to local businesses and low-income microenterprise owners serving lower-income people in small, typically rural communities.
TOD Housing Program	Provides grants and/or loans for the development and construction of mixed-use and rental housing development projects, homeownership mortgage assistance, and infrastructure necessary for the development of housing near transit stations. (Note: applies to specific transit stations in particular cities)

Private Resources

California Community Reinvestment Corporation (CCRC)	Non-profit mortgage banking consortium that provides long-term debt financing for multifamily affordable rental housing. CCRC specializes in programs for families, seniors, citizens with special needs, and mixed-use developments. Both non-profit and for-profit developers are eligible.
Federal Home Loan Bank Affordable Housing Program	Provides direct subsidies to non-profit and for-profit developers, and public agencies for the construction of affordable low-income ownership and rental projects.
Federal National Mortgage Association (Fannie Mae)	A shareholder-owned company with a Federal charter that operates in the secondary mortgage market. Fannie Mae provides a variety of mortgages for single- and multifamily housing, and has programs specifically designed for affordable housing.
Freddie Mac Home Works	A government sponsored enterprise that provides first and second mortgages
Savings Association Mortgage Company (SAMCO)	Statewide loan pool that provides thirty-year permanent loans for the construction and redevelopment of affordable housing projects, serving persons earning up to 120% of the median income.

Chapter 6: CONSTRAINTS TO HOUSING AVAILABILITY AND AFFORDABILITY

Governmental and market constraints sometimes limit the opportunity to develop property for affordable housing. Governmental constraints that the city can control include land use controls, development standards, processing fees, development impact fees, code enforcement, site improvement costs, development permit and approval processing.

Market constraints that the city cannot control consist of land cost and availability, environmental constraints, vacancy rates, construction costs, financing mechanisms, and probable buyer/tenants. These constraints may result in housing that is targeted towards moderate and above moderate households otherwise not affordable to lower income households.

The analysis does not focus on federal, state, or other governmental policies or regulations that the city cannot affect or modify. Many such policies and regulations could affect the city's ability to meet future housing needs and secure adequate funding to construct very low-income and low-income housing. Among these are:

- land use and environmental policies and regulations that could limit the city's ability to designate land within the city's planning area for future residential development (e.g., agricultural open space and natural habitat preservation, protection of endangered species, flood control);
- fiscal and financial constraints related to federal, state, or regional funding for housing, transportation, infrastructure, and services needed to support new residential development;
- Federal and state requirements that add to the cost of constructing affordable housing, when public funds are used (such as "prevailing wage" requirements); and,
- construction codes and regulations that Gridley must follow for new residential construction that could restrict the use of cost-saving techniques or materials.

While these other governmental requirements meet legitimate public purposes, Gridley recognizes that they can potentially constrain the availability and affordability of housing to meet the community's future needs. Both governmental constraints and nongovernmental are described below.

Government constraints

Land Use Zoning Districts

The City of Gridley Municipal Code, Title 17, Zoning, establishes the type, location, and density of residential development in Gridley. Zoning includes a wide assortment of zones permitting residential development, including agricultural residential, residential suburban, single-family residential, duplex residential, multiple-family residential, mixed use combining zone, and planned development combining, light and general commercial as well as industrial zoned districts.

The Agricultural Residential District (AR-5) establishes and preserves agricultural-residential districts at a population density appropriate for rural residential uses, controls non-agricultural encroachment onto prime agricultural areas, and maintains the public health and safety in areas

where water and sanitary facilities and other public services are not readily available. This district is further intended to perform the function of a buffer area between large parcel agricultural uses and more intensive urban uses, and to preserve land in open space uses of sufficient size for feasible development until such future time as urban development becomes appropriate.

The Residential Estates District (R-E) establishes and preserves single family residential neighborhoods characterized by very low densities of one dwelling unit or less per gross acre.

The Residential Suburban District (R-S) establishes and preserves single-family residential neighborhoods characterized by low densities of three dwelling units or less per gross acre and larger residential lots fronting on a public street.

The Single-Family Residential District (R-1) establishes and preserves smaller lot single-family residential neighborhoods at a low urban density of four dwelling units or less per gross acre and ensures that other uses are both compatible and convenient to the residents of such districts, with lots fronting a public street.

The Duplex Residential District (R-2) establishes and preserves residential neighborhoods at a moderate population density of eight dwelling units or less per gross acre and ensures that other uses are both compatible and convenient to the residents of such districts, with lots fronting a public street.

The Multiple-Family Residential District (R-3) establishes and preserves residential neighborhoods of higher densities of fifteen dwelling units or less per gross acre and serves as a buffer area between commercial or industrial districts and lower density residential districts, with lots fronting a public street. This zone conflicts in language in that the intent section indicates a restriction of 12 du/ac. The density allowed for SRO's, shelters, and transitional housing is limited to 45 beds/ ac. The previous section discussed the default density for Gridley at 20 du/ac. The Housing Plan will amend the R-3 zoning district to reflect the maximum density of 15 du/ac, the ability to reduce the density to less than that if the developer can show successful affordability, and provide further flexibility of density bonus up to 20 du/ac to support affordable housing projects, specifically and remove the inconsistency within the code.

The Mixed Use Combining District (MUCZ) can be applied to an area of at least 5 acres in combination with another district which permits development of residential dwellings as a primary use, in order to:

- ✓ encourage retention of mixed residential dwelling types in existing neighborhoods;
- ✓ require a mix of residential dwelling types in new developments;
- ✓ discourage segregation of residential uses into large tracts of single types;
- ✓ permit introduction of limited professional and neighborhood commercial uses into residential neighborhoods;
- ✓ provide for small-scale development of specified mixed uses without approval of a use permit; and,
- ✓ provide a density bonus which encourages development of properties with significant infrastructure constraints at a cost of land per dwelling unit which is comparable to that of properties which are less constrained.

The Restricted Commercial (C-1) and General Commercial (C-2) zones require a Conditional Use Permit (CUP) for all residential development.

The Public and Quasi-Public (PQP) zone applies to sites in public ownership and use, and to sites occupied by private or nonprofit uses of a community service nature. Emergency and transitional housing is allowed in the PQP district subject to a conditional use permit. There are sites in the city that would make sense to allow special needs housing. This section of the code will be amended to provide flexibility of housing type within the PQP zone for senior and affordable housing opportunities.

The Planned Development District (PD) permits flexibility in the use and design of land and structures where modifications of specific provisions of this title will not be contrary to the intent of the city general plan or harmful to areas adjacent to such development. It acts as a combining zone in any zoning designation in the city. The underlying zoning district determines the dominant use of the PD district and all development standards conform to the standards of the underlying zoning.

Zoning Standards

The city’s zoning ordinance establishes residential development standards in Gridley and sets requirements for densities, setback and heights for all residential development. This section describes the city’s requirements related to densities, setback, heights and other standards for residential development. Zones permitting residential development by right have specific standards that dictate density and types of housing structure permitted. In addition, areas that conditionally permit residential land uses, such as C-1 and C-2 zones have no prescribed density requirements, but are subject to discretionary development standards based on the type of housing structure proposed. **Table 42** presents existing densities for zones which permit residential development, however, proposed amendments are not noted.

Table 42
Residential Densities

Zoning District	Maximum Density	Minimum Lot Area	Minimum Lot Width	Maximum Lot Coverage	Maximum Height	Minimum Yard Requirements		
						Front Setback	Side Setback	Rear Setback
AR-5	1 unit/ 5 acres (1)	5 acres	None (2)	20%	35 ft	20 ft	20% lot width (3)	5 ft
R-E	1 unit/acre	1 acre	120 ft.	30%		30 ft	10 ft.	10 ft
R-S	3 units/acre	6,000-10,000 sf	60-95 ft.	40%	30 ft	20 ft	20 ft. (4)	10 ft
R-1	4 units/acre	6,000-7,500 sf	60-85 ft.	<8,000 sf-45%	Main building-2 stories or 30 ft	20 ft	20% lot width (3)	5 ft
R-2	8 units/acre	5,000-6,000 sf	50-75 ft.	<8,000 sf-40%		20 ft		
R-3	15 units/acre	6,000-7,500 sf	60-85 ft.	50%		20 ft		
MUCZ	None (5)	5 acres	None	Based on underlying zone	Based on underlying zone	None	None	None

C-1, C-2

PQP

Development standards are dependent on type of residential structure proposed (i.e. single family structures would be required to follow R-1 standards, multifamily R-3 standards, etc.)

PD

Parking Standards

Gridley’s parking requirements are shown in **Table 43**. Parking requirements for new construction consist of two parking spaces per unit in single-family dwellings, duplexes and triplexes, except for single-family dwellings less than 5,000 square feet built prior to July 1992.

In multifamily R-3 zoning districts, one space is required for studios and one-bedroom units and 1.5 parking spaces are required for two-bedroom units. Based on the analysis of the standards shown in the preceding tables, the city has concluded that permitted densities are adequate for the development of a diversity of housing types and income needs. As described in the chapter on Affordable Housing, several affordable housing projects have been constructed or are currently in progress in residential zones. The city’s parking requirements comply with Government Code 65915(p) and are adequate for the development of housing and achievement of permitted residential densities without being excessive and unduly increasing development costs.

**Table 43
Parking Requirements**

Land Use	Spaces Required
Single-Family, duplexes, triplexes	2 per unit
Single-family (on lot smaller than 5,000 sf and built prior to 7/1992)	1.5 per unit
Studio or one-bedroom apartment	1 per unit + 10% guest space
Multifamily (2 bedrooms or more)	1.5 per unit + 10% guest space Cottage and second dwelling units
Cottage and Second Units	1 per unit
Senior citizen dwelling (1 bedroom)	.08 per unit + 10% guest space
Boardinghouses, etc.	1 per unit
Residential care facilities	1 per 2 beds + 1 per non-residential employee on max shift
Mobile home parks	2 per unit

Zoning for a Variety of Housing Types

The zoning ordinance establishes the types of uses permitted, conditionally permitted, or prohibited in each residential zone. Housing types in Gridley include single-family dwellings, second dwelling units, manufactured housing, mobile homes, and multi-family dwellings. **Table 44** summarizes the different types of residential uses permitted or conditionally permitted in various residential zones within the city.

The city updated land use designations in the recently adopted 2030 General Plan, which will also lead to revisions to the city’s zoning standards. These revisions will include increases in permitted single-family residential densities and parking reductions for smaller residences, in order to promote and facilitate a greater diversity of housing types and income needs. The city is also proposing standards that allow higher densities in multi-family residential zones. The city is currently evaluating what amendments should be made to the code to provide consistency with the General Plan and to ensure the Housing Plan Implementation Strategies are successful.

Development standards that could constrain development of affordable housing are density, parking requirements, lot coverage, height limits, setbacks, open space requirements, and growth controls.

Gridley’s development standards are not constrictive with the exception of the R-3 density described above. Parking and setback requirements do not constrain site development in that the minimum setbacks are either 5 feet or a combination of percentage related to lot width. The city will, during this planning cycle, re-evaluate setback standards to allow maximum flexibility related to affordable housing development.

Table 44
Permitted Residential Land Uses by Zone District

Residential Uses	AR-5	RE	RS	R-1,	R-2	R-3	C-1, C-2, M-1, M-2, MUCZ, PD, PQP
Single-family dwellings	P	P	P	P	P	P	All residential development requires CUP
Condominiums					P (1)	P (2)	
Apartments					P (1)	P (2)	
Cottage Units							
Second Units	P	P	P	P	P	P	
Manufactured homes	P	P	P	P	P	P	
Mobile homes	P (3)	P (3)	P (3)	P (3)	P (3)	P	
Mobile home parks(HUD reqm'ts/review)			CUP	CUP	CUP	CUP	
Residential care facilities (< 6 persons)	P	P	P	P	P	P	
Residential care facilities (> 6 persons)	CUP		CUP	CUP	CUP	CUP	
SRO (Single Occupancy Residential)						P	
Emergency Shelters (4)							
& Transitional Housing(4)							

Source: Title 17, Gridley Municipal Code

Note:

- (1) Not to exceed 8 units or 20 bedrooms per acre.
- (2) Not to exceed 15 units or 45 bedrooms per acre.
- (3) CUP required for mobile homes not on a foundation, or for agricultural workers employed on the premises.
- (4) Conditionally permitted in PQP districts only. The PQP zone indicates emergency housing for short term, undefined and less than 6 mos. The code will be modified for clarification and to meet SB2: Transitional and supportive housing is permitted as a residential use subject to restrictions that apply to other residential dwellings of the same type in the same zone.

Figure Constraints-1
 General Plan
 Land Use Diagram

LEGEND

- Sphere of Influence
 - Planned Growth Area
 - City Boundary
- General Plan Land Use Designations
- Commercial
 - Neighborhood Center Mixed Use
 - Downtown Mixed Use
 - Agricultural Industrial
 - Industrial
 - Park
 - Open Space
 - Public
 - Residential, High Density 2 (15-30 du/ac)
 - Residential, High Density 1 (9-15 du/ac)
 - Residential, Medium Density (5-8 du/ac)
 - Residential, Low Density (2-4 du/ac)
 - Residential, Very Low Density (0.5-3 du/ac)
 - Urban Reserve
- Major Roads
 - Railroad

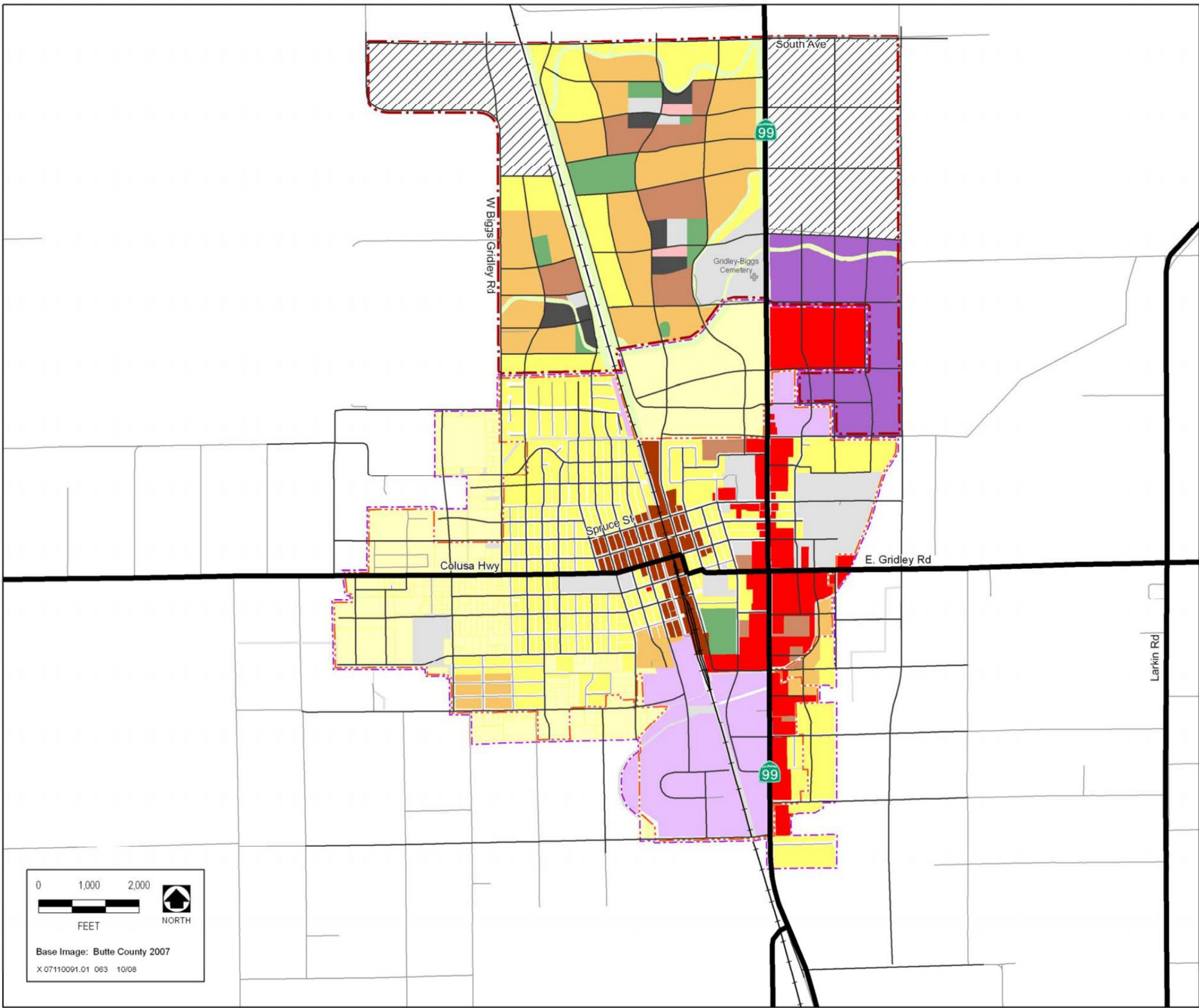

0 1,000 2,000
 FEET

NORTH

Base Image: Butte County 2007
 X 07110091.01 063 10/08

Manufactured Homes and Mobile Home Parks

State law requires that cities and counties allow the placement of manufactured homes meeting federal construction standards and manufactured home subdivisions in single family neighborhoods. In keeping with state law, the city's zoning ordinance allows manufactured homes on permanent foundations in the same residential zones as single family dwellings. Manufactured homes must comply with the same development standards as single family dwellings.

The city conditionally permits mobile home parks in R-S, R-1, R-2, and R-3 residential zones, provided that they do not exceed 8 units or 20 bedrooms per acre. The conditional use permit process is described below in the Processing and Permitting Procedures section. No special permits, separation or siting requirements are imposed for mobile home parks. The city's standards for manufactured homes and mobile home parks **do not pose constraints** to the placement or development of these housing types.

Second Dwelling Units

The zoning ordinance was amended in 2013 to permit second dwelling units by right. . The following regulations apply for the construction of second dwelling units in districts where not more than one dwelling unit is allowed per parcel:

- ✓ Not more than one second dwelling per parcel.
- ✓ Unit size not more than 1200 sq. ft. of living area.
- ✓ For detached units, compliance with the applicable district's residential development regulations, including lot coverage, building height, setbacks, signs, and parking requirements (one parking space).
- ✓ For attached units, compliance with city building code regulations pertaining to additions.
- ✓ Incorporation of same or similar architectural features, building materials and colors as the main dwelling unit or adjacent dwelling units.

The requirements described provide for second units in a variety of zones and situations (attached and detached) and **do not constrain** the development of secondary housing in the City of Gridley. The city will, as a part of its Housing Plan encourage the development of second units and will have a goal of ten second units within the city boundary.

Cottage Units

Cottage units are defined in the zoning as single-family dwelling not exceeding 640 sq. ft. in floor area. Cottage units are conditionally permitted in multi-family residential (R-3) zones. The conditional use permit process is described below in the Processing and Permitting Procedures section. No special permits, separation or siting requirements are imposed for cottage units.

Single-Room Occupancy Units

Single-Room Occupancy Units are included within the definition of multi-family dwellings. According to the zoning ordinance, “Multiple-family dwelling” means a dwelling designed or used for residential occupancy by more than two families, with or without common or separate kitchen or dining facilities, including apartment houses, dormitories, rooming houses, boardinghouses, row houses, townhouses and similar housing types, but not including hotels, motels, hospitals, or institutional residences. Multi-family structures, which are allowed in many zones, then, would include single-room occupancy units. The existing zoning ordinance also defines “efficiency unit,” which is effectively the same as a single-room occupancy unit. To further clarify that this type of housing is allowed, the City has committed to Housing Implementation Strategy 3.4. Please refer to the Housing Plan section.

Emergency Shelters, Transitional Housing, and Supportive Housing

The zoning ordinance conditionally permits transitional housing and emergency shelters providing housing on a short-term basis for individuals and families in PQP/Public and Quasi-Public districts. State law (Government Code 65583 (4) (A) requires that emergency shelters be permitted by right in one or more zones without a conditional use permit or other discretionary action, with certain exceptions, including flexibility for jurisdictions to provide emergency shelters in coordination with other agencies. In 2011, the code was amended to allow emergency shelters, transitional housing and supportive housing by right for a period of six months. Legislation requires that at least one site provide year round housing in these zones or other to ensure availability. Emergency shelters, transitional housing and supportive housing are conditionally permitted in PQP districts only for a period of 6 months or less. The PQP zone also indicates emergency housing for short term for an undefined length of time is permitted. State law requires certain findings for denial of emergency shelters and supportive and transitional housing. The zoning ordinance will be updated to comply with the provisions of State law. The code will be modified for clarification and to meet SB2 as well as the three types of housing; emergency, transitional, and supportive. The code will provide zoning for transitional and supportive housing permitted as a residential use subject to restrictions that apply to other residential dwellings of the same type in the same zone. Refer to Housing Plan, section 3.

The city will research areas that can support year round housing and ensure that the code be amended to reflect this. Please refer to the Housing Plan.

Housing for Persons with Disabilities

The City of Gridley permits state-licensed residential care facilities serving six or fewer persons in all its residential zoning districts by right. “Residential care facility” is defined in the zoning ordinance as a building designed or used as a residence for individuals who require any form of institutional care or supervision where such care or supervision is maintained on the premises during a 24-hour day. These include residential care facilities for persons with disabilities/special needs.

Residential care facilities serving seven to twelve persons are conditionally permitted in AR, RS, R1, R2, and R3 districts. The conditional use permit process is described below in the Processing and Permitting Procedures section. No special permits, separation or siting requirements are imposed for special needs housing developments.

The city ensures that new housing developments comply with California building standards (Title 24 of the California Code of Regulations) including handicapped accessibility requirements. The city also incorporates equal housing opportunity and discrimination prevention practices as addressed by the Americans with Disabilities Act, the Federal Fair Housing Act and the California Fair Employment and Housing Act of 1964. When a case of discrimination is alleged, the City refers interested persons to the appropriate agencies, such as the Community Legal Information Center, Mediation Center of the North Valley, Butte County Housing Authority, and Legal Services of Northern California. The city engages in public education efforts by supplying informational literature on fair housing in English and Spanish at public buildings and on the website.

The city currently has procedures in place to make reasonable accommodations for persons with disabilities. Through provisions set forth in the General Plan, the city annually evaluates its policies and practices to identify any constraints to housing development for persons with disabilities. The analysis includes monitoring of existing land use controls, permit and processing procedures and building codes. If any constraints are identified in these areas, the city's Planning Department initiates actions to remove the constraints or provide special accommodations. Although the City has procedures in place to ensure that reasonable accommodations can be made throughout the approval process, the zoning ordinance does not include mention of reasonable accommodations. The lack of specific provisions in the code for reasonable accommodations or exceptions to obtain permit approval could pose a constraint for persons with disabilities to receive permit approval.

Additionally, to reduce the length of the permitting process, the Building Department will expedite the plan review and in some cases, reduce building permit fees for projects that facilitate housing for persons with disabilities, as permitted by the zoning ordinance.

The City provides incentives for rehabilitation of housing for disabled persons through the provision of small grants to retrofit or rehabilitate owner-occupied dwellings for moderate- and low-income persons with disabilities. The grant cap is \$8,000 per person. If the retrofit requires temporary relocation of disabled individuals from their homes, the city is flexible and allows the granting of more funding.

In 2011, the code was modified to revise its definition of "family" to comply with Fair Housing law (42 U.S.C. Sec. 3601, et. seq.). This is no longer a government constraint.

Housing for Agricultural Workers

The zoning ordinance addresses agricultural employee housing in agricultural zoning districts as required by state law (Health and Safety Code Sec. 17021.6), which requires jurisdictions to consider agricultural employee housing as a permitted use in all agriculturally zoned districts within that jurisdiction. This was addressed in the previous plan period. In 2011 the code was amended to ensure agricultural employee housing is permitted in all agriculturally zoned districts. This is no longer a constraint.

Analysis of Land Use Controls and Development Standards

Based on the previous analysis of land use and development standards, the City has concluded that it generally facilitates the construction of a wide variety of housing types. Land use controls and development standards that may pose potential constraints on the provision of housing in the City of

Gridley include:

- ✓ The lack of a reasonable accommodation ordinance that provides clear language on permit procedures and development standards for housing that meets the needs of persons with disabilities. This lack of specific language could affect the ability of persons with disabilities to comply with city codes or obtain exceptions.
- ✓ The provision for year round emergency shelters, transitional housing and supportive housing needs to be addressed. Although the City has received no applications for emergency shelters, transitional housing, or supportive housing, the lack of an acceptable site permitting these uses year round could pose a constraint to the development of this type of housing in the city.

Refer to the Housing Plan for implementation strategies addressing these constraint issues.

Site Improvement Standards

The Public Works Department implements on- and off-site improvement requirements. The city requires developers of new subdivisions to improve all streets, pedestrian ways or easements and public utilities in, and adjacent to the subdivision. Standards for site improvements must comply with public works construction standards. All improvements are generally completed as conditions of tentative map approval and are developer financed.

The city may also require exactions (property dedications) for new subdivisions including:

- ✓ Dedication for streets, alleys, including access rights and abutter's rights, drainage, public utility easements and other public easements.
- ✓ Bicycle paths in any subdivision containing two hundred or more lots as specified in the Subdivision Map Act.
- ✓ Parks and recreation, in accordance with the General Plan, specified by the provision of the Subdivision Map Act, except where the subdivider pays an in- lieu fee in accordance with standards approved by the City Council.
- ✓ Other public purposes as the planning commission may deem necessary, provided the amount of real property required to be dedicated bears a reasonable relationship to
- ✓ the increased need for public facilities created by the subdivision.

Compliance with certain site improvements may pose a constraint on the provision of housing, particularly housing for lower-income levels if the cost of such improvements are passed on to the residential consumer. To provide some flexibility to the developer in fulfilling site improvements requirements, the zoning ordinance permits property owners to enter into a deferred improvement agreement with the city.

Provision of financial assistance towards the cost of infrastructure improvements may also help mitigate constraints to the development of housing. The city is focusing on seeking out state grants to provide the funds to assist with infrastructure requirements. Amendment of certain public works constructions standards for residential projects might reduce financial constraints posed by the fulfillment of site improvement requirements. Flexibility in street standards may allow increased land area and density, resulting in an overall reduction in the cost per lot. These are standards the city is considering and will implement such modifications provided public health and safety are not impacted.

Planning and Processing Fees

Planning and processing fees cover administrative review of proposed developments by the Planning and Public Works Departments. Gridley has adopted city-wide processing fees for all developments including single-family and multi-family developments. The City estimates that for a typical single-family unit, building permits and plan review would cost approximately \$2,410, while for a typical 6-unit multifamily project, the total building permit and plan review cost would be approximately \$5,420.

Table 45 shows a comparison of the City of Gridley's planning fees and fees from other jurisdictions in the region. In general, the City's planning and processing fees are comparable or lower compared to other jurisdictions in the County. A nexus fee study was prepared which recommended an increase to all fees. Based on the current economy, the city has determined that to support development at this time it will not increase fees.

Development Impact Fees

A variety of development impact fees are often assessed on new residential projects that include city controlled fees (such as a development application fees and building permit fees) and non-city controlled fees (such as school impact fees and utility connection fees). These fees fund infrastructure, public facilities, and transportation efforts associated with new units. Another component of project costs involves utility service connection fees (e.g. sewer and water connection fees). To ensure that impact fees reflect the actual cost of infrastructure, the City conducted a Nexus study of its impact fees in 2005 and made fee revisions in 2006. **Table 47** provides typical fee breakdowns for the City of Gridley for single-family and multifamily projects.

As shown, typical development fees for a three bedroom/two bath single-family home are estimated at approximately \$33,689, and approximately \$25,496 per unit for a multifamily project consisting of 6 two-bedroom units. When calculated into the total cost of development, impact fees represent a significant proportion of the total construction value, as estimated by the Gridley Building Department.

For comparison, the street facility improvement and maintenance equipment fees for the City of Chico are \$4,081.75 per single-family unit and \$2,822.90 per unit for multifamily projects. Fire and police fees are \$1,566 per unit for single family and \$1,521 for multifamily. In Chico, the park impact fees are somewhat lower than in Gridley: \$3,112 per unit for single-family development and \$2,642 per units for multifamily projects (including a Bidwell Park land acquisition component).² The City of Biggs' 2006 Development Impact Fee Study suggests impact fees for sewer of \$7,273 per unit, water fees of \$3,810 per unit, electricity fees of \$1,451 per unit, road fees of \$1,777 per unit, parks and recreation fees of \$3,060 per unit, police/fire fees of \$290 per unit, and approximately \$20,500 per unit total for development impact fees (not distinguishing between single-family and multifamily development).

These fees have not increased during the 4th cycle period and not anticipated to increase at this time.

Table 45
Comparison of Planning related Fees for Local Jurisdictions

Fee	Gridley	Biggs	Chico	Paradise	Oroville	Butte Co
Tentative Subdivision Map	\$2,000	\$500 + \$20/lot	\$14,950	5 or more lots- \$1,757-1,917	\$1,873.87	\$6,761 - over 15 lots 79.20/lot
Tentative Parcel Map	\$1,000	\$400 + \$25/lot	\$7,404	\$1,566	\$1,873.87	\$6,815.20
Revised Map	\$500-1,000	\$200	\$2,755.50- \$4,311	\$293-639 over 12 hrs. \$69/hr		
Preliminary Subdivision		\$400				
Boundary Line Modification	\$450	\$250	\$1,443.50	\$485 - over 7 hrs. \$69/hr		\$1,633-1,715
App. Of Determination/ Cert. of Compliance	\$300	\$100	\$676	\$426 - over 6 hrs. \$69/hr		\$2,833.80
Reversion of Acreage	\$350	\$200	\$1,557.50			
Annexation	\$800	\$600 + actual cost		\$1,598 (1)		
Environmental Impact Reports	Actual cost	Actual cost + 20%	Actual cost + 15%	\$383 or actual cost	\$3,258.90	
Environmental Review/Categorical Exemption	\$100	\$50	\$130			
Environmental Review/Environmental Evaluation	varies	\$125	\$3,569	\$383 + 5% of actual cost		
Bond Review Charge		\$200				
General Plan Amendment	\$1,500	\$500 minimum + actual cost	\$5,892	\$1,012-2,024	\$2,427.88	\$12,523.50 deposit
Zoning Charges	\$800	\$500 + actual cost	\$4,283-4,989	\$1,491-2,024	\$2,427.88	\$9,752.90 deposit
Use Permit	\$200-500	\$125	\$236-5,476	\$554-1,491	\$1,960.77	\$6,500 - \$6, 727.80
Variance	\$300	\$200	\$2,712.50-3,249	\$799-1,012	\$1,873.87	\$4,721.60
Appeals	\$200	\$50	\$1,791.50-2,927			\$50
Final Subdivision Map	\$500 + \$25/lot	\$200 + \$20/lot		\$1,012 - over 15 hrs. \$69/hr		\$2,448.40
Final Parcel Map	\$500 + \$25/lot	\$200 + \$20/lot		\$639 - over 10 hrs. \$69/hr		\$1,656.60

Fees have not increased substantially to reflect increased costs of infrastructure. As such, development impact fees do not appear to pose constraints to the development of housing, particularly low-income housing while comparing the costs to develop in Gridley to other communities close by.

**Table 46
City of Gridley
Development Impact Fees (Estimates only)**

Item	Fee	
	Single Family**	6-Unit Multi-Family Project***
Sewer (development impact + connection + collection)	\$14,570	\$69,420
Water (development impact + distribution, connection)****	\$5,026	\$17,037
Electrical connection/capacity fees	\$2,798	\$14,788
Fire and Police	\$1,720	\$10,320
Parks and Recreation	\$3,659	\$21,954
Streets and Roads	\$1,461	\$8,766
School Impact fees	\$4,455	\$10,692
Total	\$33,689	\$152,977
Total Fees Per Unit	\$33,689	\$25,496

Analysis of Fees and Exactions

The City of Gridley charges various planning review and processing fees, development impact fees, and utility service connection fees which are considerably lower than other communities. Although these fees are still a necessary cost to meet City service standards and provide necessary facilities and infrastructure, they could collectively add significant costs on housing. The city’s required fees and exactions have been established based on reasonable processing costs and the cost of providing improvements to new developments.

While the City’s development fees are within the low range for the area, fees and exactions may pose potential constraints in the following manner:

- ✓ Development impact fees and planning fees represent a significant proportion of the total development cost. These costs may pose a constraint to the development of housing, particularly for lower-income housing, as these costs are then passed on to residential consumers. However, the city’s improvement requirements are not unreasonable, and the requirement that undeveloped properties pay the full cost of curb, gutter, and sidewalk improvements along the property frontage is necessary to meet minimum health and safety requirements.
- ✓ Compliance with certain site improvements may pose a constraint on the provision of housing, particularly housing for lower-income households.

Processing, permit procedure and code enforcement

The development review and permitting process is used to receive, evaluate, and consider approval of new development applications. The development review process ensures that new residential projects reflect the goals and policies of the General Plan and meet the intent and requirements of the zoning ordinance. Code enforcement of development and building standards ensures maintenance of the City's housing stock. Descriptions of permits processing procedures and code enforcement are provided in the following subsections.

Processing and Permit Procedure Applications for development permits are made in writing to the Community Development Department. Applications vary depending on the permit being requested. In addition, some planning applications require public hearings, such as Planned Development districts. The City of Gridley meets state-required timelines for approval of development permits, as described below.

Project application review is usually completed within two to three weeks of accepting an application. Determination of approval is usually based on consistency with the General Plan, character of adjacent land uses, adequate size and shape of lots, zoning compliance, and conformance with design standards. The basic steps for development processing are as follows (example assumes that application is submitted to Building Department to construct single family dwelling or a multifamily dwelling on an existing, properly zoned, finished lot):

1. Applicant submits 3 sets of plans and plan review fee to Building Department. Applicant is informed that full initial review will take 2 to 3 weeks.
2. Copies of site plan and other relevant information are circulated to all concerned City departments (Planning, City Engineer, Public Works, Electrical, Fire, Police, Finance) for review and comments.
3. Building plans are reviewed for compliance with applicable building codes (this takes place concurrently with City departmental review).
4. All department comments are sent to the applicant via U.S mail and/or fax (usually about 2 to 3 weeks after the initial submittal).
5. A very small percentage of projects are approved during the initial review. Projects that are not approved must resubmit plans that respond to and incorporate staff comments that were issued during the initial review.
6. Resubmitted plans usually can be reviewed in 1 to 2 weeks.
7. A building permit can usually be issued within 1 day after all departments approve the application.
8. Master plans submitted for subdivision dwellings usually take about the same amount of review time.

In general, a development plan review takes 4 to 6 weeks for staff review. A project that requires approval from the City Council, such as those in Planned Development districts will require more time. Many other factors, such as public sentiment, can also factor into the determination of approval. An approved development plan is in effect for three years.

Planned Development District

A Planned Development District (PD) requires review by the Planning Commission and approval by the City Council. The application process is as follows:

1. Applicant may consult with the planning director to obtain information and guidance before making commitments or incurring substantial expense in the preparation of plans, surveys and other data.
2. The applicant submits a site development plans to the Planning Department.
3. Copies of site plan and other relevant information are circulated to all concerned City departments (Planning, City Engineer, Public Works, Electrical, Fire, Police, Finance) for review and comments.
4. After application is reviewed by all relevant City staff and deemed complete, the Planning Commission reviews the proposed project, which includes a public hearing. The Planning Commission can recommend changes that time.
5. The Planning Commission approves of recommended changes if necessary and recommends the proposed project be forwarded to the City Council.
6. The City Council considered the application and draft concept plan and may approve of the PD district if the is consistent with the General Plan and the PD district is compatible and complementary to existing and potential development in the general vicinity.
7. Once the application and draft concept plan have been approved by the City Council additional materials such as: the proposed faculties for improvements and drainage, water, sewer, power, grading plans, and the grades, widths and cross-sectional design of the proposed streets must be submitted prior to the issuance of building permits.

Conditional Use Permit

The conditional use permit process is described in the City's zoning ordinance under Chapter 17.54. A conditional use permit is a zoning instrument used to review the location, site development, or conduct certain land uses. These are uses that generally have a distinct impact on the area in which they are located or are capable of creating special problems for adjacent properties unless given special attention. A conditional use permit may be granted at the discretion of the planning director, planning commission, or city council and is not the automatic right of any applicant. Although technically allowed under the City's Code, the Conditional Use Permit (CUP) process has historically involved the Planning Commission.

Conditional use permits are not generally required for single-family or multi-family units. Conditional use permits are not required for multi-family projects in the R-3 zone. Conditional use permits are required for cottage units, mobile home parks, and residential care facilities with more than 6 beds in order to regulate design, access, transferability of use, and hours of operation. Conditional use permits are currently required for residential projects in the C-1 and C-2 zones. See Housing Implementation Strategy 3.2, which is designed to ensure that the City's conditional use permit process does not become a constraint to mixed-use and higher-density residential development.

The City's conditional use permit process has not historically presented problems in terms of processing time, expense, or certain on the part of interested multi-family housing developers. There are no development standards that would create a constraint for higher-density housing or mixed-use projects with a higher-density component. There is no minimum lot size for the C-2 or C-1 zone. The maximum building height is 50 feet. For the C-1 zone, the maximum lot coverage is 100% and for the C-2 zone, maximum lot coverage is 90%. Under the City's zoning and development standards, an additional 153 lower-income units could be developed on sites with commercial zoning. There are no other substantially constraining land use controls or applicable development standards.

The City of Gridley would require a Conditional Use Permit (CUP) for residential development within a commercial zoning district in order to ensure the health, safety and welfare of the residents are not negatively impacted by commercial activity. For example, commercial businesses have the potential to negatively impact the residential use with excessive noise and traffic. Typical downtown commercial businesses include retail, bars, restaurant and offices. These uses may generate odors and operate later in the evening. The Planning Commission generally reviews these types of applications only to ensure that both land uses are compatible and that any change of use or new development would meet standard Building and Fire Code requirements. The standards for granting a Use Permit include specific findings, as described below.

Findings

Findings for approval of a Use Permit are that "the establishment, maintenance, or operation of the use or building applied for will not under the circumstances of the particular case, be detrimental to the health, safety, peace, comfort and general welfare of persons residing or working in the neighborhood of such proposed use, or be detrimental or injurious to property and improvements in the neighborhood or to the general welfare of the city or substantially impede enactment of the comprehensive plan." (GMC 17.54.040)

The following are examples of findings that have been made for residential uses in the downtown commercial area:

1. Proper notice of the public hearing was given by legal notice in the Gridley Herald and notice mailed to property owners within 300' of the project. The Commission would consider if any surrounding businesses and residences have submitted comments relating to any negative impacts associated with the proposed residential use. Only positive comments have been submitted for these types of applications and the community is very receptive of mixed use development.
2. Notice of the public hearing, conduct of said hearing, and an opportunity for all parties to present testimony was completed in accordance the California Government Code Section 65009.

3. The project would be considered Categorically Exempt per the California Environmental Quality Act (CEQA) Guidelines Class 1, Section 15301: minor expansion to an existing facility.
4. The request for a Use Permit to for single- or multi-family residence will not under the circumstances of the particular case, be detrimental to the health, safety, morals, comfort and general welfare of the persons residing or working in the neighborhood of such proposed use because the residential use will blend well with the existing buildings and multi-family residential buildings as well as surrounding commercial uses. In addition, the proposed use will revitalize a currently vacant downtown area.
5. The residential use will not be injurious or detrimental to property and improvement in the neighborhood or to the general welfare of the city because the proposal is consistent with the surrounding neighborhood mix of commercial and residential uses.
6. Prior to residential occupancy, the structure must meet current Building Code requirements. These requirements shall be met prior to occupancy of the building or the proposed use will not be approved. Compliance with the described improvements is included in the conditions of approval of the project. This requirement ensures the safety of future occupants and surrounding neighborhood.
7. Prior to residential occupancy, the building must meet current Fire and Building Code regulations. This requirement addresses the issue of safety. Compliance with the described improvements is often included in the conditions of approval of a project.
9. The project complies with the City's General Plan Land Use Element policies by encouraging infill and compact development and by promoting a balance of housing opportunities for all ethnic groups, age and income levels. The project will provide safe, affordable housing by encouraging new construction of a currently underutilized, vacant church building.

Typical Conditions of Approval

Typically, conditions of approval for a mixed-use residential project would include the following. Prior to Residential Occupancy of the Building:

1. The applicant shall file a declaration of acceptance of the following conditions by submitting a signed copy of the conditions to the Planning Department within 30 days of the Planning Commission approval. The application shall expire one (1) year from the date of Planning Commission approval unless a building permit has been secured prior to the one (1) year date.
2. The use of the site shall be as described above. Any modifications to the approved plans shall require prior approval by the Community Development Director.
3. The applicant shall obtain a City of Gridley building permit before construction can proceed.
4. Prior to occupancy, the applicant shall comply with all Building and Fire Code regulations and all other applicable State and local codes.
5. The applicant shall provide two paved on-site parking spaces per Chapter 17.46 of the GMC.
6. Any external addition to the building shall be architecturally compatible with the existing structure as determined by the Community Development Director.

Process

When reviewing the CUP application, the Planning Commission would examine the site plan, building, landscaping or fencing, parking and if applicable the environmental impacts. The development process for a Conditional Use Permit consists of the following:

The only application requirement is a basic site plan. There is no required application or fee to participate in this process.

Most projects benefit from a preliminary review at a project management meeting. These meetings are held every week on Monday at 1 p.m. The applicant meets with representatives from all City Departments to obtain feedback on the proposal. At this time, staff will outline the development process. The Project Management team is composed of members from the following City Departments: Municipal Utilities, Public Works, Fire, and Community Development Departments.

In order to initiate the Conditional Use Permit process, the applicant must submit all required plans and fees. The day of submission will determine the Planning Commission Agenda dates. If a complete project is submitted, the project can be placed on the next available Commission meeting (meetings are held the third Monday of every month). Staff will work with the applicant to make sure they understand submittal requirements and will never wait the allowed 30-day review period to return comments. Typical project turn-around time for comments is 2 weeks.

The Planning Commission takes final action on a CUP project. For each item on an agenda for Planning Commission, the Planning staff will present a report. The Chairperson will ask the applicant or any interested person if they have comments on the project. After testimony is completed, the applicant will be allowed rebuttal. Since the Planning Commission is the final approval body for the application any party may appeal the project to the City Council if they complete the application requirements. The appeal period is ten (10) days from the Commission action. If the City Council is the Final Acting Body there is no appeal. After the final approval the applicant may submit plans for Plan Check in Building and Safety Division.

Cost

Cost for processing a Conditional Use Permit is \$300.00 total (with environmental) for a single-family owner occupied project and \$600.00 for all other applicants. This cost includes the deposit for environmental review.

Time

Typical turn-around time for an application, once deemed complete, is one month.

Environmental Review Process

Various development review and approval activities, such as general plan amendments, rezones, and specific plans, maybe subject to the California Environmental Quality Act and require the preparation of an environmental document (i.e. environmental impact report, negative declaration) before a project can be approved. The requirement to prepare an environmental document can substantially lengthen the development review process, sometimes taking up to one year to obtain project approval.

Building Code Enforcement

The City of Gridley, in accordance with the State Housing Law, establishes certain minimum requirements for residential construction. The Gridley Building Department currently administers codes and code enforcement under the California State Building Code (2010).

Processing, Permit Procedure, and Code Enforcement

The costs associated with development project review will vary between projects. Gridley utilizes an efficient and comprehensive approach towards development review and permitting that allows for quick response to developer applications. The city utilizes many practices to expedite application processing, reduce costs, and clarify the process to developers and homeowners. Increased development costs resulting from delays in the city's development review and permitting process are generally not considered a constraint on housing development.

Code enforcement of development and building standards and amendments to these standards do not constrain the production or improvement of housing in the city. The presence of an active code enforcement effort serves to maintain the condition of the city's housing stock.

Market constraints

Market constraints are those factors outside of local government that limit the availability of housing and/or the feasibility of building affordable housing. The assessment of these constraints provides a basis for possible actions by the city to offset potential effects on housing supply and cost. However, the city has little or no control over many of the governmental factors that influence the cost and availability of housing. This section evaluates nongovernmental factors such as land, construction, and financing costs and availability among other nongovernmental constraints.

Land costs

The availability and cost of land can impact the cost of housing and the feasibility of developing affordable housing for low and moderate income households. Therefore, developers sometimes seek to obtain city approvals for the largest number of lots allowable on a parcel of land. This allows the developer to distribute the costs for infrastructure improvements (i.e., streets, sewer lines, water lines, etc.) over the maximum number of homes. The average costs of single-family residential properties range from \$935,000 for 5.85 acres (\$3.67 per sq. ft.) to \$135,000 for 8,276 sq ft (\$16 per sq. ft.). Costs per single-family lot range from approximately \$55,012 to \$135,000. Current sales of multifamily zoned properties were limited to one property priced at approximately 2 acres for \$400,000 (\$5 per sq. ft. or approximately \$202,000 per acre).

Construction costs

Construction costs can vary widely depending on multiple factors, such as the type of construction, custom versus tract development, materials, site conditions, finishing details, amenities, square-footage, and structural configuration. Multiple family residential housing generally costs less to construct than single-family housing. Residential construction costs vary depending on the quality of materials and the size of the home being constructed.

Single Family Construction Costs

Information from the city and a nonprofit developer provide an estimate of construction costs for single-family housing. The city estimates construction costs of a typical wood framed 1,500 square-foot, single-family home is \$117,864 (\$84 per square foot), plus land costs. The construction costs of a 1,080 square foot single-family home in the recently developed Locust Estates subdivision totaled \$91,633 (\$78 per square foot), plus land. The cost fluctuates depending upon the interior finishes and other construction materials.

Multifamily Construction Costs

Information from the city and a nonprofit developer provide an estimate of construction costs for multifamily housing. The city estimates costs for a typical multifamily wood framed 3,600 square foot apartment building with six 2-bedroom units of 600 square feet each at \$48,000 per unit (\$80 per square foot), of a total development cost of \$288,000 plus land. However, depending on the type, size and quality of construction for multifamily projects, the cost of construction can vary widely and reach estimates of up to \$200 per square foot, for an estimated average construction cost of \$140 per square foot within the city.

Soft Costs

Soft costs are costs unrelated to the construction of housing, and may include engineering and architectural fees, insurance, financing, and administrative costs. For a single-family development, average soft costs are estimated at approximately \$35 per square foot, based on construction cost estimates for recently developed affordable housing projects at Locust Estates and Bowwood Subdivision. Permitting costs and impact fees for a typical single-family residence are estimated at \$34,817.50. For multi-family development, fees per unit are estimated at \$21,550.43.

Once a vacant parcel is purchased, the contractor must complete site improvements to prepare for building on the property. If labor or material costs increased substantially, the cost of construction in Gridley could rise to a level that impacts the price of new construction and rehabilitation. However, because construction costs are consistent throughout the region, the City of Gridley can do little to reduce this constraint.

Analysis of Land Costs and Construction Costs

Based on the information presented above, total development costs for a new single-family home are estimated in the range of \$130,000 to \$170,364 for typical homes ranging in size from about 1,000 square feet to 1,500 square feet. Assuming costs of between \$55,000 and \$135,000 for a ready to build single-family lot, the total cost for a single family home may range from a low of \$185,000 to an estimated high of \$305,364, if individual lots were purchased for home construction.

The estimated development costs of a multifamily unit of 600 square feet, including land purchase and soft costs, is approximately \$102,700 per unit. While development costs indicate that at least some of the new housing stock may be affordable to moderate- and lower-income households, some larger homes and apartments may be unaffordable for some lower-income households, particularly for larger households. Falling home prices may impact the willingness of homebuilders to construct new housing developments. This is a constraint the city has not effect upon.

Availability of financing

The difficulty of credit availability constrains financing for home building, purchase or rehabilitation in the region, state and nation as a whole. Typically, fluctuating interest rates can eliminate many potential homebuyers from the housing market or render a housing project infeasible that could have successfully developed or marketed at lower interest rates.

The increased use of alternative mortgage products over the past two decades has allowed buyers to pay lower initial interest rates and monthly payments and receive larger home loans than they might otherwise qualify for based on their income. Even during periods of high interest rates, these alternative products allow more buyers to qualify for homeownership, thus minimizing the swings in home sales that accompany changes in interest rates. However, long term costs are less predictable with these loan types. If a buyer has an adjustable rate mortgage, for example, the “resetting” of the interest rate to a higher rate can lead to significant increases in monthly payments, even though the amount of principal owed remains the same. The unpredictability of an interest rate rise on an adjustable rate mortgage can be especially troublesome to a homeowner who barely qualified for a home loan at the initial low interest rate. The availability of these loans has declined in response to the subprime mortgage crisis, reducing the number of homebuyers with sufficient income or wealth to qualify for mortgage financing.

The recent tightening of credit due to the foreclosure crisis in the past 5 years, may result in significant constraints that are not in the city’s control, to consumer access to fixed-interest-rate mortgages, which would allow residential consumers to afford higher-priced homes when interest rates are lower. Most governmental programs that seek to increase homeownership among low and moderate income households rely on loan products that provide fixed interest rates below prevailing market rates, either for the principal loan or for a second loan that provides part of the down payment for home purchase. As such, the lack of available credit may create further challenges to homeownership opportunities despite government programs to assist low- and moderate-income homebuyers.

Equal Opportunity in Financing

Discrimination in the loan review process present further barriers to credit access for traditionally underserved communities. According to public data available through the Home Mortgage Disclosure Act (HMDA), lenders more frequently deny loan requests to minority applicants than White applicants as a whole within the County. This continues to be a constraint, but out of the city’s control as a government constraint.

Analysis of the Availability of Financing

Based on the information presented above, access to credit represents a constraint on the availability and affordability of housing. Continued volatility in the subprime loan market and increased foreclosures may result in continued tightening of the credit market in the future. Lack of access to equal credit due to potential racial and ethnic discrimination by financial institutions may create additional barriers for residential consumers, particularly for borrowers with lower incomes and credit ratings. Tighter credit markets may also affect the ability of developers to finance construction of new housing.

Chapter 7: PROGRAM EVALUATION

An evaluation of the city's accomplishments under the existing Housing Element is necessary to ensure progress towards its stated goals. In accordance with Government Code Section 65588, the City of Gridley is required to review its Housing Element to evaluate the following:

- ✓ The appropriateness of the housing goals, objectives, and policies in contributing to the attainment of the state housing goal.
- ✓ The effectiveness of the housing element in attainment of the community's housing goals and objectives.
- ✓ The progress of the city, county, or city and county in implementation of the Housing Element.

Gridley's Housing Element 2009-2014 included housing goals that concentrated on five broad aspects of the housing market and formed the basis for housing policy and programs for five years. These goals include the following:

- ✓ **Housing Quality:** Promote the development of new housing which meets safety standards, offers a variety of housing types in a variety of locations, and enhances existing neighborhoods, services and the environment.
- ✓ **Housing Quantity:** Encourage the preservation of existing housing and the construction of new housing at a cost and in quantities to meet the needs of all income groups, including very-low, low-, and moderate-income groups.
- ✓ **Affordable Housing:** Promote affordability of housing of all types to meet the present and projected needs of households of all income levels.
- ✓ **Equal Housing Opportunity:** Assure that discrimination is not a factor in the ability of households to obtain housing.
- ✓ **Natural Resources:** Promote the conservation of natural resources and energy in housing production.

Demonstrating its ongoing commitment to affordable housing, the city has approved several projects with affordable housing components during the previous planning period. The city approved an affordable rental unit project, the construction of fourteen single family affordable homes through the Chico Housing Improvement Program(CHIP), and also partnered with CHIP to renovate underutilized multi-story structure in the downtown into a rent restricted affordable senior housing project. The city supports investment in the existing housing stock through the Gridley Program Income Housing Rehabilitation Loan Program. The city provided a \$500,000 loan for the renovation of an affordable housing development to income-qualified families for home improvements. The State of California abolished Redevelopment Agencies in 2011, eliminating the funding source for the rehabilitation program, however, Gridley has insured a continued commitment for affordable housing.

The city has partnered with local housing authorities to serve lower-income and special needs households. The city works with Regional Housing Authority of Sutter and Nevada Counties to provide information to income-qualified families to renovate their homes. The city Administrator continues in open dialogue with the Authority throughout the year to support programs for affordable housing. The city also took action to reduce permit processing constraints on developers to encourage the production of housing.

The city has a Planned Development Overlay that has been applied to new subdivisions. The overlay zone allows project architectural review to be conducted within the subdivision, streamlining the changes of materials related to the aesthetics of a development thus reducing city review requirements linking architecture to the entitlement action.

Gridley supports the special needs “at-risk” populations by processing code amendments to address State law requirements for emergency shelters and transitional and supportive housing. The revised Zoning Code permits emergency shelters “by right” in the Light Manufacturing (LM) and Public/Quasi Public (PQ) zones, and includes definitions for transitional and supportive housing that allow these uses the same level of review given to other residential housing types. The city will revisit this code amendment to increase the time period from 6 months to one year per the State requirements.

Other accomplishments

The City of Gridley has achieved or made notable progress during the extended economic downturn in implementing its housing goals under the current Housing Element planning period:

- ✓ During the **2009-2014 Housing Element Planning Period** the following new residences were constructed:

<u>Units</u>	<u>Affordability</u>
• Six single family residential units	extremely low
• Fifty-four multi-family residential units	very low income
• Fourteen single family residential units	low income
• Two single family residential units	moderate income
• Fifteen single family units	above moderate income

Total = Ninety-four units

- ✓ During the 2009-2014 Housing Element Planning Period, six deed restricted units in Gridley Springs II were rehabilitated;
- ✓ During the 2009-2014 Housing Element Planning Period, twenty-three single family very-low and low income units were rehabilitated;
- ✓ The city amended the Second Unit Ordinance to bring the review process (permitted by right) and allowable size of unit (1200 square feet) in line with state legislation.
- ✓ The city amended the Gridley Municipal Code establishing an ordinance for Density Bonus;
- ✓ The city began the review process for a comprehensive amendment to Title 17 of the Gridley Municipal Code to bring zoning incompliance with the General Plan 2030;
- ✓ The city completed the 56-unit rental property at Washington Court priced for very low and low income households. The project consists of 2 and 3-bedroom apartments.
- ✓ Thirteen (13) self-help housing units at Locust Estates were completed through \$660,000 in funds received from the Joe Serna, Jr. Farmworker Housing Grant Program, in addition to other state and federal assistance. Locust Estates is a project sponsored through Community Housing Improvements Program’s (CHIP’s) sweat equity program. An additional 6 new units for low-income households were completed at the Bowwood subdivision through this sweat equity program.

Housing production unmet need (2009-2014)

The regional target set by BCAG through its Regional Housing Needs Allocation (RHNA) for the 2009-2014 planning period was 1,068 units. The city was able to show available land inventory for 778

housing units. The remaining 290 units anticipated a rezone of land to accommodate the unmet need.

Gridley had a RHNA of 1,068 housing units. While the element demonstrated it had sufficient sites to accommodate 783 units, it contained a rezone program to accommodate the 288 units remaining need for lower and moderate income households. The city did not complete the rezoning as described in the housing element program action. Over the previous 5 years, 94 units were constructed leaving an unmet need of 288 units consisting of 91 very low income units, 17 low income units, and 180 moderate income units.

**Table 47
Unaccommodated Housing Need (2009-2014)**

	Very Low	Low Income	Moderate	Above Moderate	Total
RHNA Goal	258	133	182	495	1,068
1) Units Constructed	60	14	2	15	94
2) Previously identified sites currently available (capacity)	107	102	0	480	689
3) Sites rezoned pursuant to Housing Implementation Strategy 2.5	0	0	0	0	0
4) Remaining need	91	17	180	0	288
Total Remaining Need	91	17	180		

The 2014-2022 planning period RHNA Allocation consist of 231 very low, 118 low, 99 moderate and 321 above moderate housing units. The sum of the unmet need for the previous planning period and the current allocation is shown below in Table 2.

**Table 48
RHNA Allocation Total**

	Very Low	Low Income	Moderate	Above Moderate	Total
RHNA Unaccommodated Need 2009-2014	91	17	180	0	288
RHNA Allocation 2014-2022	231	118	99	321	769
Total RHNA 2014-2022	322	135	279	321	1,057

The city needs to provide adequate lands for the following capacity:

- **457 Units Very Low-Low*** R-3 zoning minimum 15-20 du/ac
- **600 Units Moderate –Above Moderate** R-S/R-1/R-2 zoning 3-8 du/ac

*The number of extremely low income units is calculated as 50% of the number of required very low units therefore the need results in 228 extremely low income units and 229 very low income units

CITY OF GRIDLEY, CALIFORNIA
Table 49 - Housing Element Review and Revise
Progress Toward Meeting 2009-2014 Housing Element Goals and Objectives
(Govt. Code Section 65588)

Notes:

1. The listing of a policy/program description may have more implementation strategies associated with it. The descriptions are taken verbatim from the approved 2009-2014 Housing Plan. The continuance of a policy/implementation strategy may have revised language when translating it into the 2014-2022 Housing Plan.
2. The plans that are associated with Housing Implementation Strategy (HIS) 2.5 are not appended to this table. Refer to the 2009-2014 document.
3. Table Plan 2, Summary of Quantified Objectives: 2009-2014 is not appended to this table, but are fully discussed in the text.

Policy/Program Description	Housing Implementation Strategy (HIS)	Objective Quantified/Qualified	Result	Evaluation	Continue/Modify/Delete
<p>Housing Quality <i>Housing Goal 1: To promote the development of a variety of housing types throughout the City that is safe and complements the surrounding neighborhood.</i></p>					
<p>HP-1.1: The City will maintain and enforce development standards and building standards that provide housing and safe neighborhoods for housing all income levels.</p> <p>Timing: Ongoing</p> <p>Responsibility: Building Department</p>	<p>HIS 1.1: On a request basis, the Building Department will continue to inspect buildings for Health and Safety Standards and Building Code violations. Buildings found in violation of Health and Safety Standards and/or Building Codes will be required to be rehabilitated to current Codes and Standards. Informational brochures shall be developed to inform residents of this service. The City will continue its current program to maintain a code violations database and notice property owners of code violations. The City will research options for addressing code violation problems with absentee property owners, including surveying other cities' approaches. The Planning Department will bring a recommendation and/or options for addressing this situation to the City Council for consideration and action, including, but not limited to revisions to the City's nuisance abatement procedures.</p>	<p>Resolve code violations.</p>	<p>The City continues to perform housing inspections as part of its regular code enforcement activities.</p> <p>Brochures are in the process of being developed and information is distributed on the City website.</p> <p>Code enforcement is maintaining data and continues to notice property owners of violations. The City works very hard to help homeowners bring their property into conformity.</p>	<p>City staff investigates building and zoning violations when requested. The request can come from a property owner recently informed that there is a violation, an interested buyer, an appraiser, or others. Due to staff shortages, the database has not been able to be updated. Efforts have been on a day-to-day complaint basis and the City has not had the opportunity to effectively investigate absentee owners. Staff has not analyzed programs in other cities and therefore have not brought this issue forward to the City Council with recommendations.</p>	<p>Modify:</p> <ol style="list-style-type: none"> 1. Update the database of code violations. 2. Analyze other city's programs and what programs are in place for absentee owners. 3. Provide information on the City website.
<p>HP-1.2: The City will encourage the development and redevelopment of neighborhoods that include a variety of housing types and sizes.</p> <p>Timing: Following General Plan Adoption; Target 2011</p> <p>Responsibility: Community Development Department</p>	<p>HIS 1.2: The Community Development Department will conduct a housing condition survey in order to determine the housing in the City in need of rehabilitation as an update to the 2006 Housing Conditions Survey conducted by the City. The City will analyze the results of the Housing Conditions Survey to help prioritize and apply the City's efforts and application of funding for housing rehabilitation.</p>	<p>Update City's knowledge of local housing conditions.</p>	<p>The City conducted a visual survey of housing units during 2010-2011. There is an indication from this review that approximately 64% of the housing would benefit by of non-structural repairs; roof, window, paint, etc.</p> <p>Using the sample survey format, a complete housing survey was conducted indicating that there exist approximately 10 units of the City's housing stock that were structurally degraded. Approximately 30% of the units could use paint, window replacement for energy efficiency upgrades, roof replacement, etc. None of the repairs are structural. Most of the improvements could come from yard maintenance to increase neighborhood curb appeal.</p>	<p>Data indicates that the housing stock is maintaining structural integrity while needing general repairs and maintenance such as roofing, painting, and window and door upgrades as well as better general yard maintenance as well.</p> <p>There were approximately 10 homes that were candidates for structural repairs/demolition.</p> <p>The City should continue to visually inspect the homes needing structural repairs and sample the neighborhoods to improve visual curb appeal.</p>	<p>Modify:</p> <ol style="list-style-type: none"> 1. Evaluate houses that appear to have structural issues and determine if low interest funding could aid the homeowner. 2. Develop community outreach to encourage better exterior energy/aesthetic maintenance and loan programs for roofing, painting, and window replacement. 3. Outreach related to water conservation, better yard plantings that require less maintenance to improve general curb appeal.

CITY OF GRIDLEY, CALIFORNIA
Table 49 - Housing Element Review and Revise
Progress Toward Meeting 2009-2014 Housing Element Goals and Objectives
(Govt. Code Section 65588)

Notes:

1. The listing of a policy/program description may have more implementation strategies associated with it. The descriptions are taken verbatim from the approved 2009-2014 Housing Plan. The continuance of a policy/implementation strategy may have revised language when translating it into the 2014-2022 Housing Plan.
2. The plans that are associated with Housing Implementation Strategy (HIS) 2.5 are not appended to this table. Refer to the 2009-2014 document.
3. Table Plan 2, Summary of Quantified Objectives: 2009-2014 is not appended to this table, but are fully discussed in the text.

Policy/Program Description	Housing Implementation Strategy (HIS)	Objective Quantified/Qualified	Result	Evaluation	Continue/Modify/Delete
<p>HP-1.3: The City will encourage the maintenance of existing housing to prevent deterioration and promote dwelling lifespan.</p> <p>Timing: Ongoing</p> <p>Responsibility: Community Development Department</p>	<p>HIS 1.3: In coordination with the Consolidated Area Housing Authority of Sutter County, the City will continue the Gridley Housing Rehabilitation Program to provide financial assistance to owner and renter lower-income households for housing rehabilitation during this planning cycle. The Housing Rehabilitation Program will be publicized in brochures made available at City Hall, the library, and electronically on the City's website.</p>	<p>Provide financial assistance to 30 owner and renter lower-income households for housing rehabilitation during this planning cycle.</p>	<p>The City rehabilitated 87 affordable units (Gridley Oaks rehabilitation & Gridley Springs I and II rehabilitation) during the planning period. The Consolidated Area Housing Authority of Sutter County merged and became the Regional Housing Authority of Sutter and Nevada Counties</p>	<p>The program was very successful in the rehabilitation of units that were also considered "at-risk" units. The funding for the rehabilitation secure continued affordability of the units.</p>	<p>Modify</p> <ol style="list-style-type: none"> 1. Provide financial assistance to 15 owner and renter lower income households for housing rehabilitation during this planning cycle working with the housing authority.
<p>Housing Quantity – To facilitate the preservation and construction of housing to meet the needs of Gridley residents, including all household types and incomes.</p>					
<p>HP-2.1: The City will encourage infill development, through reduced or delayed payment of impact fees, priority in entitlement review, or other methods.</p> <p>Timing: Following General Plan Adoption; Target 2011</p> <p>Responsibility: Planning Department</p>	<p>HIS 2.1: The Planning Department will prepare and maintain information on vacant infill properties designated by the City for urban development. The objective of this program is to make readily available data that is helpful to builders and land developers in preliminary research that could lead to redevelopment and infill development that forwards the City's planning goals. The City will survey builders, developers, and experts in real estate to determine the types of information that would be most helpful in making property investment decisions, and the City's property database should report on the same information as feasible. The information on vacant available properties could take the form of an online database or it could take other formats.</p>	<p>Facilitate infill development.</p>	<p>The City created a database of vacant sites that could be developed for residential use during the previous planning period.</p> <p>The City continues to communicate with local builders and developers to develop vacant infill parcels.</p> <p>There hasn't been an opportunity to reduce or delay fees to facilitate/expedite development.</p>	<p>Due to the economic downturn development has been generally stagnant. Recently there are a few new homes being constructed (2013/14) in developments previously approved with all infrastructure in place. The City has continued its dialogue with builders to determine sites that are more viable for development during the economic challenges facing the City.</p>	<p>Continue/Modify</p> <ol style="list-style-type: none"> 1. Provide data on the website depicting vacant sites that could be built upon. 2. Provide data on the website related to building permits issued.
<p>HP-2.2: The City will encourage the construction of second units within existing and proposed residential lots.</p> <p>Timing: Following General Plan adoption; Report to Council in 2010 on options for changes to plans, policies, and procedures to induce infill development; implement changes to City documents and codes, as appropriate through 2014.</p> <p>Responsibility: Planning Department, Building</p>	<p>HIS 2.2: The City will identify a range of incentives that could encourage development of vacant and underutilized properties in and near downtown Gridley. The City will specifically consider incentives that would encourage housing development, including affordable housing development. Develop a range of incentives to encourage development of vacant and under-utilized properties in and near downtown Gridley. The City will survey builders and developers to determine which incentives would be most effective in inducing infill housing development. In surveying developers and builders, the City will make a specific effort to gather input from local developers and builders and those with experience developing affordable housing, multi-family housing, small lot single-family housing, and infill development of all types,. City staff will also collect and analyze relevant programs from other</p>	<p>Facilitate infill development.</p>	<p>The City has not fully realized this objective. Gridley continues to encourage the development of second units and amended the code to be consistent with state legislation.</p> <p>The economic downturn has impacted financial incentive programs. City staff informally contacted interested builders and developers for ideas to incentivize infill development.</p>	<p>The policy of encouraging the construction of second units at existing residential sites and new home development will be maintained. This is an on-going effort. The City continues to look for ways to facilitate infill housing and continue the dialogue with builders to incentivize development at infill sites.</p>	<p>Continue/Modify</p> <ol style="list-style-type: none"> 1. City staff would meet with developers informally or via telephone conferencing related to incentives for infill development and new housing opportunities. 2. City staff will review programs developed in other cities of similar size that could be informative and provide innovative ideas that would stimulate development.

CITY OF GRIDLEY, CALIFORNIA
Table 49 - Housing Element Review and Revise
Progress Toward Meeting 2009-2014 Housing Element Goals and Objectives
(Govt. Code Section 65588)

Notes:

1. The listing of a policy/program description may have more implementation strategies associated with it. The descriptions are taken verbatim from the approved 2009-2014 Housing Plan. The continuance of a policy/implementation strategy may have revised language when translating it into the 2014-2022 Housing Plan.
2. The plans that are associated with Housing Implementation Strategy (HIS) 2.5 are not appended to this table. Refer to the 2009-2014 document.
3. Table Plan 2, Summary of Quantified Objectives: 2009-2014 is not appended to this table, but are fully discussed in the text.

Policy/Program Description	Housing Implementation Strategy (HIS)	Objective Quantified/Qualified	Result	Evaluation	Continue/Modify/Delete
Department, and City Council	<p>cities and counties that have had success with infill development. Staff will present City Council with options for incentives, which could include, but is not limited to reduction of fees, delay in payment of impact fees, reduced processing times for infill development consistent with the General Plan. Based on this approval of changes to the Municipal Code or other necessary actions to create incentives for infill development, including infill housing development.</p> <p>The City will collect and analyze relevant programs from other cities and counties that have had successful infill development.</p>				
<p>HP-2.3: The City will encourage compact development, the use of drainage swales for stormwater conveyance, multi-use public facilities and lands, and other planning and design strategies to reduce the cost of infrastructure to serve new housing.</p> <p>Timing: Following General Plan adoption; Target 2010 for drafting of a Nexus Fee Study, update to development impact fees, and preparation and dissemination of educational materials on second units.</p> <p>Responsibility: Planning Department</p>	<p>HIS 2.3: The City will encourage the construction of second units housing to meet future housing needs in Gridley The City will provide educational materials regarding second units to those seeking building permits for housing and those wishing to subdivide land for housing. The City will reduce development impact fees for second units, as necessary, to encourage their development. The City will follow adoption of a comprehensive General Plan Update with a Nexus Fee Study and Impact Fee Update. The City has described the intent for this program throughout the General Plan.</p> <p>The Fee Update will be tailored according to the City's infill and compact development objectives and affordable housing objectives. Please refer to the 2030 General Plan, including Public Facilities Implementation Strategy 1.2, Land Use Implementation Strategy 2.3, and Circulation Implementation Strategy 1.2 for more information.</p> <p>As a part of the Fee Update, the City will analyze the costs and public services demand for second units, and align impact fees to better represent actual public costs. For second units, development impact fees would be expected to be substantially lower than the typical single-family detached home.</p>	<p>Encourage production of at least 10 second units in this housing element planning horizon.</p>	<p>City staff is continuing to work on providing informational materials placed at the public counter.</p> <p>The City conducted a nexus fee study and found that some of the recommendations to increase fees would be onerous at this time to implement due to the current economic downturn. The City wished to continue to keep fees as low as possible to encourage the continuation of construction in the City.</p> <p>The City continues to encourage second units and believes it can reach this goal in this planning horizon. The City approved one second unit in 2012.</p>	<p>The implementation strategy continues to be valid. Second units are a model that can substantially improve existing neighborhoods by providing on-site living quarters for family members, or, to provide rental income. The aspect of a rental would by default meet affordable housing needs generally because the size of unit.</p> <p>The nexus fee study was not adopted by City Council because the study determined that impact and development fees were too low. The City did not wish to place more economic hardship on developers and have continued to keep the existing fees at this time.</p>	<p>Continue/Modify.</p> <p>The City will encourage second units to meet housing needs. Educational materials and community outreach will be conducted at least one time per year. Additionally, information will be placed on the City website.</p> <p>The City will revisit the Nexus Fee Study and Impact Fee update in 2016. A review of the previous recommendations will be considered if they are appropriate at that time.</p>
<p>HP-2.4: The City will encourage infill development in meeting the housing needs</p>	<p>HIS 2.4: The City will consider a range of incentives to induce the rehabilitation of existing multi-family housing, adding bedrooms to existing housing, and conversion of</p>	<p>Facilitate production of 3 larger rental units per year following the City Council's approved program</p>	<p>The City continues to look at viable incentives supporting living area additions providing more bedrooms in existing</p>	<p>The economic downturn of 2005 to present has dampened development or additions to homes. The City is</p>	<p>Continue/Modify</p> <p>1. Conduct community outreach for</p>

CITY OF GRIDLEY, CALIFORNIA
Table 49 - Housing Element Review and Revise
Progress Toward Meeting 2009-2014 Housing Element Goals and Objectives
(Govt. Code Section 65588)

Notes:

1. The listing of a policy/program description may have more implementation strategies associated with it. The descriptions are taken verbatim from the approved 2009-2014 Housing Plan. The continuance of a policy/implementation strategy may have revised language when translating it into the 2014-2022 Housing Plan.
2. The plans that are associated with Housing Implementation Strategy (HIS) 2.5 are not appended to this table. Refer to the 2009-2014 document.
3. Table Plan 2, Summary of Quantified Objectives: 2009-2014 is not appended to this table, but are fully discussed in the text.

Policy/Program Description	Housing Implementation Strategy (HIS)	Objective Quantified/Qualified	Result	Evaluation	Continue/Modify/Delete
<p>required by expanding populations.</p> <p>Timing: Report to Council within 18 months of Housing Element adoption; actions considered within 20 months of Housing Element adoption.</p> <p>Responsibility: Planning Department, Planning Commission, City Council</p>	<p>existing nonresidential buildings to serve the needs of Gridley's larger families. The City will also encourage development of new rental housing that accommodates larger-household needs, providing more than 1- and 2-bedroom units.</p> <p>City staff will consult with local housing authorities on Gridley's desire to rehabilitate building to provide multi-family housing with three or more bedrooms per unit.</p> <p>The City will consult with local housing authorities regarding applications for grant funding to rehabilitate housing, add a 3rd bedroom, and convert buildings for multi-family residential use.</p> <p>The City will consider collaborative development of a revolving loan program through a local housing authority, other public programs, or the City's Redevelopment Agency.</p> <p>City staff will report to the City Council a recommended set of actions to encourage rehabilitation of housing and conversion of existing nonresidential building stock for larger, multi-family housing. The City will revise the Municipal Code, fees, and standards, as appropriate, to provide the selected combination of incentives.</p>	implementation.	<p>homes. The City has found due to the economic downturn, additions have slowed. The City has been encouraging larger additions to existing homes when applications are submitted to the City Building Department. The City continues to have open dialog with local housing authorities regarding grant applications available.</p> <p>This objective continues to be monitored and the City supports larger rental units that meet existing codes.</p>	<p>supportive of additions to existing homes and the development of larger units to meet large family needs.</p> <p>The City has worked with local housing authorities and others to find grant funding for private single family home through its CDBG Program Income.</p>	<p>funding programs available that could be used to enlarge existing residences; newspapers, website, community meetings.</p> <ol style="list-style-type: none"> 2. Conduct outreach to the Builder's community to determine the viability of the conversion of large homes to multi-family homes. 3. Continue partnering with local housing authorities.
<p>HP-2.5: The City's infill and new growth housing incentives should be designed to achieve not only the City's housing goals, but also economic, social, and environmental goals of the City through programs identified in the 2030 General Plan.</p> <p>Timing: Submit proposed pre-zoning to LAFCO within 12 months of adoption of the Housing Element; accept annexation and development application request within 18 months of adoption of the Housing Element. Rezone at least 5.4 acres of property</p>	<p>HIS 2.5: With the conservative estimates provided in this Housing Element, the City is 290 units short of meeting its RHNA allocation. In order to meet this obligation, the City will identify areas adequate to accommodate construction of 182 moderate-income units, 17 low-income units, 31 very low-income units, and 60 extremely low-income units by 2014.</p> <p>As shown, the City has identified more than 135 acres as potential sites for rezoning near infrastructure and without substantial environmental constraints that could accommodate the City's remaining housing needs within this planning period. The property identified by the City previously had a development application submitted to the City that included 9.8 acres for multi-family housing at 20 units per acre (196 units). This previous application also proposed 465 units of single-family residential with varying lot sizes (661 dwelling units in total) and 10 acres of commercial development. This application is currently inactive. A draft environmental impact report (EIR) was</p>	Rezone properties that would accommodate development of 182 moderate-income units, 17 low-income units, 31 very low-income units, and 60 extremely low-income units.	<p>The City continues to coordinate and review opportunities for infill and new construction in looking forward to meeting the RHNA housing obligations.</p> <p>The City has not met the planned property rezone to meet the RHNA housing numbers. The City continues to look at alternatives for developing sites that could be more successful; eg. Closer to facilities and transit opportunities.</p>	<p>The City determined that land was needed to rezone to meet the previous RHNA numbers. The City was obligated to provide land to develop:</p> <ul style="list-style-type: none"> • 182 Moderate Income Units • 17 Low Income Units • 31 Very Low Income Units • 60 Extremely Low Income Units <p>The owner of the 135 acres did not continue processing the development application, therefore, the City anticipated rezoning approximately 9.8 acres to meet this need.</p> <p>Further analysis and land inventory for this 2014-2022 Housing Element has identified adequate lands that will</p>	Delete HIS-2.5 Continue HP-2.5.

CITY OF GRIDLEY, CALIFORNIA
Table 49 - Housing Element Review and Revise
Progress Toward Meeting 2009-2014 Housing Element Goals and Objectives
 (Govt. Code Section 65588)

Notes:

1. The listing of a policy/program description may have more implementation strategies associated with it. The descriptions are taken verbatim from the approved 2009-2014 Housing Plan. The continuance of a policy/implementation strategy may have revised language when translating it into the 2014-2022 Housing Plan.
2. The plans that are associated with Housing Implementation Strategy (HIS) 2.5 are not appended to this table. Refer to the 2009-2014 document.
3. Table Plan 2, Summary of Quantified Objectives: 2009-2014 is not appended to this table, but are fully discussed in the text.

Policy/Program Description	Housing Implementation Strategy (HIS)	Objective Quantified/Qualified	Result	Evaluation	Continue/Modify/Delete
<p>within City limits if annexation is not approved by June 30, 2012. Complete rezoning of at least 5.4 acres within the existing City limits, if necessary, by December 30, 2012.</p> <p>Responsibility: Planning Department, Planning Commission, City Council</p>	<p>prepared for this project prior to it becoming inactive.</p> <p>This parcel is located within the City's current Sphere of Influence but not within current City limits. As a part of the previous application, pre-zoning to a "Planned Development" zoning district was requested, in addition to annexation and approval of subdivision of property. The City did not have approval of pre-zoning in the SOI amendment for the subject parcel.</p> <p>At the time the City started its recently completed comprehensive General Plan Update, the status of this development application was uncertain. Therefore, in order to analyze the "worst-reasonable case scenario" (from an environmental impact perspective), the City assumed development of the aforementioned 661 units and 10 acres of commercial development for the subject parcel as a part of the programmatic Environmental Impact Report that accompanied the General Plan Update.</p> <p>In order to accommodate the RHNA, as a part of the Sphere of Influence amendment request to the Butte Local Agency Formation Commission (LAFCO) that follows the General Plan Update, the City will request a "Planned Development" district pre-zoning for site. Conditions for the Planned Development pre-zoning district to guide annexation, subdivision, development of this parcel will include:</p> <ul style="list-style-type: none"> ✓ A minimum of 5.4 acres in zoning districts that allow renter and owner-occupied multi-family development of a minimum of 20 units per acre by right (without the need for a conditional use permit, planned unit development, or other discretionary action) and that can accommodate the City's remaining RHNA of 108 lower-income units (low income plus very low income plus extremely low income). Each parcel selected for rezoning in this category must be capable of allowing at least 16 units based on parcel size, configuration, development standards, and other factors. At least 54 of the required 108 dwelling units shall be developed using residential zoning districts. ✓ A minimum of 28 acres of land in zoning 			<p>support the 5th cycle RHNA allocations as well as the deficit from the 2009-2014 RHNA allocation based upon existing vacant lands currently zoned for residential development and based on assumed densities of the existing zoning.</p> <p>The need to rezone land is no longer necessary, therefore, this implementation strategy would not be continued; the policy HP-2.5 would continue as it is a guiding element to the proposed Housing Plan.</p>	

CITY OF GRIDLEY, CALIFORNIA
Table 49 - Housing Element Review and Revise
Progress Toward Meeting 2009-2014 Housing Element Goals and Objectives
 (Govt. Code Section 65588)

Notes:

1. The listing of a policy/program description may have more implementation strategies associated with it. The descriptions are taken verbatim from the approved 2009-2014 Housing Plan. The continuance of a policy/implementation strategy may have revised language when translating it into the 2014-2022 Housing Plan.
2. The plans that are associated with Housing Implementation Strategy (HIS) 2.5 are not appended to this table. Refer to the 2009-2014 document.
3. Table Plan 2, Summary of Quantified Objectives: 2009-2014 is not appended to this table, but are fully discussed in the text.

Policy/Program Description	Housing Implementation Strategy (HIS)	Objective Quantified/Qualified	Result	Evaluation	Continue/Modify/Delete
<p>districts that would accommodate development of housing appropriate for moderate-income households allowing a density of at least 8 units per acre.</p> <p>If annexation of the subject property is not approved by June 30th, 2012, the City will provide zoning and a General Plan land use designation for at least 5.4 acres within existing City limits not included in the City's inventory of sites to accommodate a minimum of 108 lower-income units. The City anticipates use of the Residential High Density (RHD-2) land use designation, which accommodates high-density development of 15 to 30 units per acre. The subject lands will have zoning that accommodates a minimum of 20 units per acre by right (without the need for a conditional use permit, planned unit development, or other discretionary action) and the site will be able to accommodate at least 16 units.</p> <p>There is a parcel of 10.21 acres within the existing City, without substantial environmental constraints, and with access to infrastructure. The front portion of the site is developed with a nursery. The back part of the site is vacant.</p> <p>Figure Plan-2 (see existing Housing Plan) shows the City's intent for this property if annexation does not occur on the 135-acre property in terms of the appropriate General Plan land use designation. This site currently has a split zoning of R-3 and C-2 (General Commercial) and therefore was not included in the sites inventory in this Housing Element for that reason. It is APN 021-110-039-000. The back portion of the site is currently zoned R-3 (approximately 7.3 acres). If annexation proceedings do not occur on the 135-acre site identified above, the City will rezone the back portion of this property to accommodate high-density housing, as noted.</p> <p>The site previously identified for rezoning (the 135-acre site) above is better suited to provide affordable housing since it is larger, in the next primary growth area of the City, has attracted development interested in the past, and has had draft environmental analysis completed already. Since this site is better suited, the City would not propose to add the above referenced 10.21-acre site to the City's sites inventory unless the site in the City's sphere of</p>					

CITY OF GRIDLEY, CALIFORNIA
Table 49 - Housing Element Review and Revise
Progress Toward Meeting 2009-2014 Housing Element Goals and Objectives
 (Govt. Code Section 65588)

Notes:

1. The listing of a policy/program description may have more implementation strategies associated with it. The descriptions are taken verbatim from the approved 2009-2014 Housing Plan. The continuance of a policy/implementation strategy may have revised language when translating it into the 2014-2022 Housing Plan.
2. The plans that are associated with Housing Implementation Strategy (HIS) 2.5 are not appended to this table. Refer to the 2009-2014 document.
3. Table Plan 2, Summary of Quantified Objectives: 2009-2014 is not appended to this table, but are fully discussed in the text.

Policy/Program Description	Housing Implementation Strategy (HIS)	Objective Quantified/Qualified	Result	Evaluation	Continue/Modify/Delete
<p>HP-2.6: The City will support planning and zoning changes to improve land use compatibility, safe multi-modal connections, location, and quality of housing in the southeastern portion of the City near Highway 99.</p>	<p>influence is not proposed for annexation.</p>	<p><i>There is no corresponding implementation strategy or objective associated with HE-2.6.</i></p>	<p>The City continues to support land use compatibility for transportation and land use.</p>	<p>This policy is substantially a part of city procedures currently in place. Each area of the city that is identified with conflict of use is evaluated for funding to rectify inconsistencies as possible.</p>	<p>Delete</p>
<p>HP-2.7: The City will maintain adequate sites with appropriate zoning, development standards, access to public infrastructure and facilities needed to facilitate a variety of types of housing for the needs of all income levels and special needs groups, including rental housing, factory built or manufactured housing, mobile home, emergency shelters, and transitional housing.</p>	<p><i>There is no corresponding implementation strategy or objective associated with HE-2.7.</i></p>	<p><i>There is no corresponding implementation strategy or objective associated with HE-2.7.</i></p>	<p>The City is reviewing and considering properties within the City boundary and within its SOI to rezone that would accommodate the housing needs of the community.</p>	<p>The City will continue to evaluate the sites that are identified as viable residential development sites.</p>	<p>Continue/Modify</p> <ol style="list-style-type: none"> 1. The City will ensure the sites identified for development to meet RHNA allocation. Development standards shall be in conformance to the requirements at the time of development. 2. The City shall encourage a mixture of income housing type with developments that are proposed.

CITY OF GRIDLEY, CALIFORNIA
Table 49 - Housing Element Review and Revise
Progress Toward Meeting 2009-2014 Housing Element Goals and Objectives
(Govt. Code Section 65588)

Notes:

1. The listing of a policy/program description may have more implementation strategies associated with it. The descriptions are taken verbatim from the approved 2009-2014 Housing Plan. The continuance of a policy/implementation strategy may have revised language when translating it into the 2014-2022 Housing Plan.
2. The plans that are associated with Housing Implementation Strategy (HIS) 2.5 are not appended to this table. Refer to the 2009-2014 document.
3. Table Plan 2, Summary of Quantified Objectives: 2009-2014 is not appended to this table, but are fully discussed in the text.

Policy/Program Description	Housing Implementation Strategy (HIS)	Objective Quantified/Qualified	Result	Evaluation	Continue/Modify/Delete
Code Consistency and Updates – To reduce and remove constraints to development and redevelopment of housing.					
<p>HP-3.1: The City shall maintain a zoning ordinance, Municipal Code, and development review process that is free of constraints for development of housing to achieve the City's regional share of estimated future housing needs for all housing types and incomes.</p> <p>Timing: Ongoing</p> <p>Responsibility: Planning Department, Planning Commission, City Council</p>	<p>HIS 3.1: The City shall review the zoning ordinance on an ongoing basis to determine its effectiveness in achieving the goals to the General Plan and its compliance with State Laws.</p>	<p>Ensure zoning achieves General Plan goals.</p>	<p>The City has accomplished this objective and continues to find ways to improve the codes, create accessibility to a seamless development process. The City has experienced a reduction in applications to build due to the economic downturn. Staff continues to look at ways to remove development barriers related to the Gridley Municipal Code.</p>	<p>The City is in the process of reviewing the code as it relates to the 2030 General Plan anticipating a comprehensive amendment to the Gridley Municipal Code, Title 17.</p>	<p>Continue</p>
<p>HP-3.1</p> <p>Timing: Annually</p> <p>Responsibility: Planning Department, Building Department</p>	<p>HIS 3.2: The City will review the Housing Element on an annual basis to determine the effectiveness in achieving goals and objectives.</p> <p>The City will provide annual reports as to the implementation of the Housing Element to the Planning Commission, City Council, and the Department of Housing and Community Development, as required by Government Code Section 65400.</p> <p>The City will consider revisions to Housing Element programs, if necessary, to address issues of efficacy relative to goals and objectives.</p> <p>As a part of this annual reporting, the Community Development Director will report on the City's design review process, as established by Design Implementation Strategy 2.3 in the Community Character and Design Element and Land Use Implementation Strategy 2.2 in the Land Use Element. The Director will also report on the conditional use permit process as it relates to multi-family housing development.</p> <p>The Director will report on the processing time, required application materials, and estimated costs for applicants attributable to the City's design review process and</p>	<p>Ensure Housing Element is achieving goals and objectives. Ensure City's design review and entitlement process does not impede higher-density housing and mixed-use development.</p>	<p>The City has submitted annual reports to the State of California Housing and Community Development for the CY 2009-2013.</p>	<p>This implementation strategy is also a requirement by the State.</p>	<p>Continue</p>

CITY OF GRIDLEY, CALIFORNIA
Table 49 - Housing Element Review and Revise
Progress Toward Meeting 2009-2014 Housing Element Goals and Objectives
(Govt. Code Section 65588)

Notes:

1. The listing of a policy/program description may have more implementation strategies associated with it. The descriptions are taken verbatim from the approved 2009-2014 Housing Plan. The continuance of a policy/implementation strategy may have revised language when translating it into the 2014-2022 Housing Plan.
2. The plans that are associated with Housing Implementation Strategy (HIS) 2.5 are not appended to this table. Refer to the 2009-2014 document.
3. Table Plan 2, Summary of Quantified Objectives: 2009-2014 is not appended to this table, but are fully discussed in the text.

Policy/Program Description	Housing Implementation Strategy (HIS)	Objective Quantified/Qualified	Result	Evaluation	Continue/Modify/Delete
	<p>conditional use permits related to higher- density housing. The City will consider revisions to the City's design review process and conditional use permit process, as necessary, to avoid impediments to higher-density and mixed-use housing developments.</p> <p>The City will monitor its development and processing/review procedures on an ongoing basis to minimize the time required for review by the City. The City will consider measures to reduce the plan review time needed by City staff by prioritizing review of permit applications for affordable housing projects, when proposed.</p>				
<p>HP-3.1 Timing: Within 12 months of Housing Element adoption Responsible Agency/Department: Planning Department, City Council.</p>	<p>HIS 3.3: The City will amend the zoning ordinance to allow emergency shelters in the PQP and M-1 zone by right, without the need for a conditional use permit or other discretionary action. The City currently allows emergency shelters conditionally in the PQP zone. However, because there are a limited number of vacant sites with this zoning designation, emergency shelters will also be allowed by right in the M-1 zone, which has 17 acres of vacant land and additional land that would be considered underutilized.</p>	<p>Facilitate development of emergency shelters. Comply with current state law requirements.</p>	<p>Title 17 of the Gridley Municipal Code was amended to allow emergency shelters in the PQP and ;M-1 zones by right. The code was amended to allow such shelters for a period of 6 months by right. This was implemented by the City Council adopting Ordinance 797 in 2011.</p>	<p>The code was amended but did not fully meet the requirements outlined by statute. The code will be amended to meet the requirements.</p>	<p>Modify</p>
<p>HP-3.1 Timing: Within 12 months of Housing Element adoption Responsible Agency/Department: Planning Department, City Council.</p>	<p>HIS 3.4: The City will amend the zoning ordinance to define and allow transitional and supportive housing in all residential zones, subject to the same development standards as would apply to a residential structure of the same housing type. The City may require a reasonable design review process for housing proposed to provide 7 or more units, or as required by the City's zoning ordinance for other types of higher-density housing. The City may require that operators provide evidence of applicable state licensing, where appropriate.</p> <p>The City shall revise the zoning ordinance to specifically define and allow single-room occupancy units (SROs), boarding houses, apartment hotels, community apartments, and stock cooperative apartments in the R-3 zone by right.</p>	<p>Facilitate development of transitional and supportive housing. Comply with current state law requirements.</p>	<p>Title 17 of the Gridley Municipal Code was amended to define transitional and supportive housing adopted by the City Council in 2011, Ordinance 797.</p>	<p>The code was amended but did not fully meet the requirements outlined by statute. The code will be amended to meet the requirements.</p>	<p>Modify</p>
<p>HP-3.1 Timing: Within 12 months of</p>	<p>HIS 3.5: The City will amend the zoning ordinance to define and allow agricultural employee housing as a permitted use within the Agricultural Residential District, as</p>	<p>Facilitate development of farmworker housing. Comply with current state law requirements.</p>	<p>Title 17 of the Gridley Municipal Code was amended to allow agricultural employee</p>	<p>The code amendment was adopted to meet the implementation strategy and</p>	<p>Delete</p>

CITY OF GRIDLEY, CALIFORNIA
Table 49 - Housing Element Review and Revise
Progress Toward Meeting 2009-2014 Housing Element Goals and Objectives
(Govt. Code Section 65588)

Notes:

1. The listing of a policy/program description may have more implementation strategies associated with it. The descriptions are taken verbatim from the approved 2009-2014 Housing Plan. The continuance of a policy/implementation strategy may have revised language when translating it into the 2014-2022 Housing Plan.
2. The plans that are associated with Housing Implementation Strategy (HIS) 2.5 are not appended to this table. Refer to the 2009-2014 document.
3. Table Plan 2, Summary of Quantified Objectives: 2009-2014 is not appended to this table, but are fully discussed in the text.

Policy/Program Description	Housing Implementation Strategy (HIS)	Objective Quantified/Qualified	Result	Evaluation	Continue/Modify/Delete
<p>Housing Element adoption</p> <p>Responsible Agency/Department: Planning Department</p>	<p>required by the California Health and Safety Code (Sec. 17021.6) and according the requirements of the Employee Housing Act (sections 17000 – 170652.5). The City will update the zoning ordinance to allow farmworker housing in City agricultural zoning districts, in compliance with Health and Safety Code Section 17021.6.</p>		<p>housing by right in the Agricultural Residential zoning District. This was implemented by the City Council adopting Ordinance 797 in 2011.</p>	<p>no further amendment to the code is required.</p>	
<p>HP-3.1</p> <p>Timing: Ongoing</p> <p>Responsible Agency/Department: Planning Department</p>	<p>HIS 3.6: The City will continue to use weekly Project Management Meetings to facilitate development proposals. These meetings are intended to promote development by addressing the development requirements and concerns early in the process. Department heads and applicants attend the meeting and it is free of charge.</p>	<p>Streamline approval of development proposals that are consistent with the General Plan</p>	<p>This policy and implementation strategy are a part of the normal course of information exchange between various departments. City staff engage with developers and/or applicants early in the process as a matter of established procedures.</p>	<p>Weekly meetings take place to discuss potential projects, ongoing projects, and other activities within the City. This is a part of the procedures and conduct of the operation of the City. City staff are made available to discuss development requirements whenever there is interest.</p>	<p>Delete</p>
<p>Affordable Housing – To promote development and redevelopment of affordable housing.</p>					
<p>HP-4.1: The City will promote the preservation of subsidized affordable housing developments.</p> <p>Timing: Contact property owners of publicly assisted rental housing at least one year prior to the expiration of the affordable housing covenant for each property to determine future ownership plans; implement preservation strategy if owners indicate desire to sell or convert their properties; Ongoing through 2014.</p> <p>Responsibility: Planning Department</p>	<p>HIS 4.1: The City will coordinate with the Butte County Housing Authority, Community Housing Improvement Program (CHIP), Consolidated Area Housing Authority of Sutter County, and other nonprofit affordable housing organizations, along with property owners of privately-owned, government-subsidized affordable housing projects to maintain the affordability status of affordable housing units in Gridley.</p> <p>The City will contact property owners of such affordable housing projects at least one year in advance of the date where properties could convert to market rate. The City will coordinate with area agencies and nonprofits to examine options for maintaining affordability status. The City will assist in identifying funds to maintain the affordability of rental units. If the owner expresses an interest in selling or converting their properties, the City will notify potential operators of subsidized affordable housing to determine interest in acquisition and operation of such properties, or will get assistance in seeking another interested investor or nonprofit housing corporation to acquire and continue operating the rental development for low-income households.</p>	<p>Preservation of affordable rental housing units.</p>	<p>The City has been coordinating efforts with housing agencies to implement preservation of affordable housing. Significant efforts have been successful to funnel funds to CDBG housing for two housing projects—The Oaks and Gridley Springs which have undergone rehabilitation and stayed as affordable housing.</p>	<p>This has been a successful strategy and will be continued. The City is desirous of ensuring affordable housing is available within the community.</p>	<p>Continue/Modify</p> <p>1. The Consolidated Area Housing Authority of Sutter County has changed to Regional Housing Authority of Sutter and Nevada Counties.</p>

CITY OF GRIDLEY, CALIFORNIA
Table 49 - Housing Element Review and Revise
Progress Toward Meeting 2009-2014 Housing Element Goals and Objectives
(Govt. Code Section 65588)

Notes:

1. The listing of a policy/program description may have more implementation strategies associated with it. The descriptions are taken verbatim from the approved 2009-2014 Housing Plan. The continuance of a policy/implementation strategy may have revised language when translating it into the 2014-2022 Housing Plan.
2. The plans that are associated with Housing Implementation Strategy (HIS) 2.5 are not appended to this table. Refer to the 2009-2014 document.
3. Table Plan 2, Summary of Quantified Objectives: 2009-2014 is not appended to this table, but are fully discussed in the text.

Policy/Program Description	Housing Implementation Strategy (HIS)	Objective Quantified/Qualified	Result	Evaluation	Continue/Modify/Delete
<p>HP-4.2: The City and Redevelopment Agency will require replacement housing per state law (or relocation of displaced residents) within the Redevelopment Project Area for subsidized housing proposed for demolition.</p> <p>Timing: Ongoing through 2014</p> <p>Responsibility: Community Development Department</p>	<p>HIS 4.2: Contact possible sources of self-help housing, such as Community Housing Improvement Program (CHIP), the area housing authorities, or Habitat for Humanity. Coordinate with these groups to identify incentives or resources needed to facilitate self-help housing development. The City will consider incentives, such as fee reductions, delay in development impact fee payments and planning or zoning permit fees until occupancy, and streamlining of the entitlement review process to encourage development of self-help housing. The City will help promote the self-help housing to the public through information made available at City Hall and on the City's website.</p>	<p>Facilitate 5 new self-help housing units within the City by 2014.</p>	<p>The City was successful in 2010 to support the 13-unit Locust Estates subdivision that was developed via CHIPS sweat equity program. The City will continue supporting these programs and look for ways to streamline the development process.</p>		<p>Continue</p>
<p>HP-4.3: Seek and support housing needs of special groups such as seniors, handicapped persons, farmworkers, those in need of temporary shelter, single-parent families, and large families.</p> <p>Timing: Ongoing</p> <p>Responsibility: Planning Department</p>	<p>HIS 4.3: The City will coordinate with the Consolidated Area Housing Authority of Sutter County to administer a First-Time Homebuyer Program.</p>	<p>Support first time homebuyers.</p>	<p>This objective has not yet been successful due to significant challenges to home buyers resulting from the recent economic downturn. The City is committed to doing what it can to support first time homebuyers where it is feasible.</p>	<p>The City has been working with the housing authority in support of the First Time Homebuyer Program. Due to the economy, there has been very little interest. The City plans to continue to support this program.</p>	<p>Continue</p>
<p>HP-4.4: Assist in the development of housing affordable to extremely low, very-low, and low-income households through financial and/or technical assistance to affordable housing developers.</p> <p>Timing: Report to City Council on discussions with other public agencies on the feasibility of consortiums for affordable housing bond financing within 12 months of the adoption of the Housing Element. Participation in</p>	<p>HIS 4.4: The City will consult with local housing authorities and non-profits regarding opportunities for financing programs, such as mortgage credit and bond financing, as feasible, to provide assistance to lower- and moderate-income homebuyers and first-time homebuyers.</p> <p>The City will determine the feasibility of participating in a consortium with other public agencies to take advantage of tax- exempt bond financing for affordable housing and for assistance to lower- and moderate-income households. Feasibility will be based on the amount of funding that could be used within the City in relation to the cost of participation and the attractiveness of these certificates to first-time homebuyers. The City will also need to consider administrative capacity for any management responsibility for financing programs.</p>	<p>Increase financing options for affordable housing projects.</p>	<p>The City continues its conversation with entities to provide opportunities to finance affordable residential projects.</p> <p>The City has advertised financing for affordable housing via the local housing authorities. Upon request, city staff refer interested parties to the various affordable housing agencies.</p> <p>The City has not extended a comprehensive financing package for affordable housing, though it has supported the rehabilitation of low income housing projects including at-risk units.</p> <p>The City will continue to find ways to enhance its ability to provide such</p>	<p>This has been a successful partnership in the past for the rehabilitation and new construction for affordable housing.</p>	<p>Continue/modify 1. Develop target activities that can be met.</p>

CITY OF GRIDLEY, CALIFORNIA
Table 49 - Housing Element Review and Revise
Progress Toward Meeting 2009-2014 Housing Element Goals and Objectives
(Govt. Code Section 65588)

Notes:

1. The listing of a policy/program description may have more implementation strategies associated with it. The descriptions are taken verbatim from the approved 2009-2014 Housing Plan. The continuance of a policy/implementation strategy may have revised language when translating it into the 2014-2022 Housing Plan.
2. The plans that are associated with Housing Implementation Strategy (HIS) 2.5 are not appended to this table. Refer to the 2009-2014 document.
3. Table Plan 2, Summary of Quantified Objectives: 2009-2014 is not appended to this table, but are fully discussed in the text.

Policy/Program Description	Housing Implementation Strategy (HIS)	Objective Quantified/Qualified	Result	Evaluation	Continue/Modify/Delete
financing programs, as feasible, ongoing through 2014. Responsibility: Planning Department, Finance Department	The availability of financing for affordable housing should be advertised locally through brochures, quarterly newsletters, the City's website, local newspapers, civic buildings, and local finance agencies and real estate offices.		services. Staff has taken these discussions to the City Council for direction as well.		
HP-4.5: The City should proactively identify and apply for funding to expand affordable local housing opportunities. Timing: Meet annually or more frequently as appropriate. Responsibility: Planning Department, Finance Department	HIS 4.5: The City will cooperatively pursue funding for affordable housing projects with the Consolidated Area Housing Authority of Sutter County and the Butte County Housing Authority. A representative of the City will meet annually and additionally during the year as needed with representatives of each housing authority to determine their interest in, and plans for, constructing affordable housing in Gridley. The City will consult with the State Department of Housing and Community Development for assistance in identifying the most appropriate state and/or federal funding sources for the affordable housing most needed in Gridley and with the housing authorities to administer affordable housing development.	Pursue at least one funding opportunity for affordable housing construction every other year.	The City has been taking an active role to pursue funding opportunities with the Sutter and Butte County Housing Authorities and received grants to offer homeowners a way to improve their property.	The City has an ongoing process to maintain communication with the State to determine funding opportunities for municipal governments.	Continue
HP 4.3 Timing: Contact area nonprofits and agencies on farmworker housing opportunities by 2010; assist with implementation of programs as appropriate through 2014. Responsibility: Planning Department	HIS 4.6: The City will assist in the development of housing for farmworkers by partnering with other agencies and nonprofits to maintain, improve, or construct new farmworker housing in the Gridley General Plan Study Area. The City will assist the housing authorities and CHIP with applications for funding for farmworker housing projects, as appropriate. City staff will contact area farmers, representatives of Butte County, and other agencies and stakeholders to identify strategies and locations for expanding farmworker housing in the Gridley area, as necessary, to meet housing needs.	Facilitate farmworker housing improvement and development in the Gridley area.	Title 17 of the Gridley Municipal Code was amended to allow agricultural employee housing by right in the Agricultural Residential zoning District. This was implemented by the City Council adopting Ordinance 797 in 2011.	The code amendment has implemented this strategy.	Delete
HP 4.4	HIS 4.7: The City will adopt a density bonus ordinance in compliance with Government Code Section 65915, which requires up to three concessions, depending upon the percentage of affordable units in the development.	Encourage development of housing for lower-income households.	The City adopted a Density Bonus code amendment meeting the requirements.	The code amendment implemented this strategy.	Delete

CITY OF GRIDLEY, CALIFORNIA
Table 49 - Housing Element Review and Revise
Progress Toward Meeting 2009-2014 Housing Element Goals and Objectives
(Govt. Code Section 65588)

Notes:

1. The listing of a policy/program description may have more implementation strategies associated with it. The descriptions are taken verbatim from the approved 2009-2014 Housing Plan. The continuance of a policy/implementation strategy may have revised language when translating it into the 2014-2022 Housing Plan.
2. The plans that are associated with Housing Implementation Strategy (HIS) 2.5 are not appended to this table. Refer to the 2009-2014 document.
3. Table Plan 2, Summary of Quantified Objectives: 2009-2014 is not appended to this table, but are fully discussed in the text.

Policy/Program Description	Housing Implementation Strategy (HIS)	Objective Quantified/Qualified	Result	Evaluation	Continue/Modify/Delete
<p>Timing: Meet annually or more frequently as appropriate.</p> <p>Responsibility: Planning Department, Planning Commission, City Council</p>					
<p>HP 4.1-4.7</p> <p>Timing: Current and ongoing through 2014</p> <p>Responsibility: Planning Department</p>	<p>HIS 4.8: The City will implement its housing policies and strategies in a way that specifically considers the needs of extremely low-income households. The needs of extremely low-income households are already included as a part of strategies discussed throughout the Housing Element that address production/preservation of residential care facilities, supportive housing, farmworker housing, and other types of housing that would be expected to serve extremely low-income households. Examples of such programs in this Housing Element include Housing Implementation Strategies 1.3, 2.2, 2.4, 2.5, 3.2, 3.4, 3.5, 4.1, 4.2, 4.5, 4.6, and 4.7.</p> <p>The City will coordinate with the Community Housing Improvement Program (CHIP), Butte County Housing Authority, Consolidated Area Housing Authority of Sutter County, and other operators of local subsidized housing projects to track the number of units provided to extremely low-income households and maintain the affordability of existing housing units that provide housing to extremely low income households. To address the housing needs of extremely low-income households, the City will identify and meet with nonprofit builders who specialize in building housing for extremely low-income households and supportive housing. This effort is designed to:</p> <ul style="list-style-type: none"> --build a long-term partnership in development; --gain access to specialized funding sources, including applying for funding sources that are targeted to the needs of extremely low-income households; --identify potential sites and streamlining strategies for ELI housing developments; --identify the range of local resources and assistance needed to facilitate the development of housing for extremely low-income households; and 	<p>Maintain and increase the supply of housing for extremely low-income households.</p>	<p>The activities outlined in this strategy have been implemented unless otherwise described above.</p>	<p>This strategy is a synopsis of similar strategies that have been addressed above and in other policies. This is redundant to the information above.</p>	<p>Delete</p>

CITY OF GRIDLEY, CALIFORNIA
Table 49 - Housing Element Review and Revise
Progress Toward Meeting 2009-2014 Housing Element Goals and Objectives
(Govt. Code Section 65588)

Notes:

1. The listing of a policy/program description may have more implementation strategies associated with it. The descriptions are taken verbatim from the approved 2009-2014 Housing Plan. The continuance of a policy/implementation strategy may have revised language when translating it into the 2014-2022 Housing Plan.
2. The plans that are associated with Housing Implementation Strategy (HIS) 2.5 are not appended to this table. Refer to the 2009-2014 document.
3. Table Plan 2, Summary of Quantified Objectives: 2009-2014 is not appended to this table, but are fully discussed in the text.

Policy/Program Description	Housing Implementation Strategy (HIS)	Objective Quantified/Qualified	Result	Evaluation	Continue/Modify/Delete
	<p>--promote a variety of housing types, including higher density, multifamily supportive, single room occupancy and shared housing.</p> <p>The City will use the quantified objectives provided in Table Plan-2 for extremely low-income households to measure success of the wide range of Implementation Strategies throughout the Housing Element that are designed, in part, to address the needs of extremely low-income households. Where opportunities exist to identify targets within the context of each Implementation Strategy, the City will ensure that the needs of extremely low-income households are considered. For example, the City's ongoing efforts to apply for HOME funds to support affordable housing will consider units to be provided for extremely low-income households.</p>				
Equal Housing Opportunity – To ensure equal opportunity and access to housing for all residents.					
<p>HP-5.1: Promote housing opportunities for all persons regardless of race, religion, sex, marital status, ancestry, national origin, or color.</p> <p>Timing: Ongoing</p> <p>Responsibility: Planning Department</p>	<p>HIS 5.1: The City will refer interested persons to the appropriate agencies, such as the Community Legal Information Center, Mediation Center of the North Valley, Butte County Housing Authority, and Legal Services of Northern California for assistance in fair housing matters. The City will act as an independent third-party to discrimination complaints, as they arise. The City will continue to provide informational fair housing brochures in English and Spanish available to the public at City Hall, the library, the U.S. Post Office, Butte County Family Services, Gridley Family Health Center, and on the City's website.</p>	<p>Assist in referral for fair housing matters.</p>	<p>The City refers individuals to the agencies that can best help them.</p> <p>The City will provide information regarding fair housing. The City is committed to creating a brochure and have information on the website for easy availability.</p>	<p>The policies and implementation strategies for equal housing are a part of the City's daily procedures.</p>	<p>Continue</p>
<p>HP-5.2: The City will encourage universal design in new housing construction, as well as integration of accessibility features in existing housing structures.</p> <p>Timing: Within 12 months of the Housing Element adoption</p>	<p>HIS 5.2: Amend the Municipal Code definition of "family" to comply with the Federal Fair Housing Act (42 U.S.C. Sec. 3601, et. seq.) provisions for persons with disabilities. Provide for unrelated persons who jointly occupy and have equal access to all areas of a dwelling unit and who function together as an integrated unit.</p>	<p>Accommodate a variety of household types.</p>	<p>The City amended Title 17 providing a definition of "family" by the City Council adopting Ordinance 797, in 2011. This objective has been fulfilled.</p>	<p>The code amendment met the implementation strategy.</p> <p>The City is reviewing the zoning code as it relates to universal design and will continue to encourage these elements in new construction.</p>	<p>Continue/Modify implementation strategy</p>

CITY OF GRIDLEY, CALIFORNIA
Table 49 - Housing Element Review and Revise
Progress Toward Meeting 2009-2014 Housing Element Goals and Objectives
(Govt. Code Section 65588)

Notes:

1. The listing of a policy/program description may have more implementation strategies associated with it. The descriptions are taken verbatim from the approved 2009-2014 Housing Plan. The continuance of a policy/implementation strategy may have revised language when translating it into the 2014-2022 Housing Plan.
2. The plans that are associated with Housing Implementation Strategy (HIS) 2.5 are not appended to this table. Refer to the 2009-2014 document.
3. Table Plan 2, Summary of Quantified Objectives: 2009-2014 is not appended to this table, but are fully discussed in the text.

Policy/Program Description	Housing Implementation Strategy (HIS)	Objective Quantified/Qualified	Result	Evaluation	Continue/Modify/Delete
<p>Responsibility: Planning Department</p>					
<p>HP-5.3: The City will promote awareness of accessibility requirements and opportunities for builders, developers, and residents.</p> <p>Timing: Within 12 months of the Housing Element adoption</p> <p>Responsibility: Planning Department</p>	<p>HIS 5.3: The City will adopt a written reasonable accommodation ordinance to provide exception in zoning and land-use for housing for persons with disabilities. This procedure will be a ministerial process, with minimal or no processing fee. Community Development Department staff will use the following or similar criteria in approving reasonable accommodations:</p> <p>The request for reasonable accommodation will be used by an individual with a disability protected under fair housing laws.</p> <p>The requested accommodation is necessary to make housing available to an individual with a disability protected under fair housing laws.</p> <p>The requested accommodation would not impose an undue financial or administrative burden on the City.</p> <p>The requested accommodation would not require a fundamental alteration in the nature of the City's land-use and zoning program.</p> <p>The City will either revise the Municipal Code or adopt stand-alone rules, policies, and procedures for reasonable accommodations. The City's procedures will specify exceptions to zoning and development standards and exceptions to building regulations needed to accommodate housing access for persons with disabilities. The City's amended procedures shall specific targeted timeframes for approval of reasonable accommodations.</p>		<p>The City has not adopted a universal design ordinance. Refer to HP 5.2 and HIS 5.2 above.</p>	<p>The City is reviewing the zoning code as it relates to universal design and will continue to encourage these elements in new construction.</p> <p>This is an ongoing process and the City is committed to optimizing access to persons with disabilities. The City has an ongoing policy to process accommodation requests rapidly and will continue to do so.</p>	<p>Continue/Modify to combine HIS 5.2 and 5.3.</p>
<p>HP-5.4: The City will provide equal access to its development policies, practices, and procedures to all residents of the City.</p> <p>Timing: Ongoing</p> <p>Responsibility: Building Department</p>	<p><i>There is no corresponding implementation strategy or objective associated with HE-5.4.</i></p>		<p>This policy is a part of the daily procedure and protocol of the city.</p>	<p>This policy is a part of the daily procedure and protocol of the city and not needed in the housing plan as a policy or implementation strategy.</p>	<p>Delete</p>

CITY OF GRIDLEY, CALIFORNIA
Table 49 - Housing Element Review and Revise
Progress Toward Meeting 2009-2014 Housing Element Goals and Objectives
(Govt. Code Section 65588)

Notes:

1. The listing of a policy/program description may have more implementation strategies associated with it. The descriptions are taken verbatim from the approved 2009-2014 Housing Plan. The continuance of a policy/implementation strategy may have revised language when translating it into the 2014-2022 Housing Plan.
2. The plans that are associated with Housing Implementation Strategy (HIS) 2.5 are not appended to this table. Refer to the 2009-2014 document.
3. Table Plan 2, Summary of Quantified Objectives: 2009-2014 is not appended to this table, but are fully discussed in the text.

Policy/Program Description	Housing Implementation Strategy (HIS)	Objective Quantified/Qualified	Result	Evaluation	Continue/Modify/Delete
Natural Resources and Energy Conservation – To reduce household costs and conserve natural resources and energy in housing production.					
<p>HP-6.1: In order to reduce long-term household utility costs, the City will promote new housing construction and retrofits designed to consume less energy, produce and use renewable energy, consume less water.</p> <p>Timing: Ongoing</p> <p>Responsibility: Building Department</p>	<p>HIS 6.1: Project applicants for building permits must show compliance with the state’s energy conservation requirements at the time building plans are submitted.</p> <p>The Building Department will continue to be responsible for implementing the state’s energy conservation standards. This includes checking of building plans and other written documentation showing compliance and the inspection of construction to ensure that the dwelling units are constructed according to those plans.</p>	<p>Ensure new development is designed to reduce ongoing building energy costs to future residents.</p>	<p>Through the building permit process, housing units are required to meet Title 24 energy calculations. The City will continue to do so in its capacity of plan check determining if a structure meets the State requirements.</p>	<p>This policy and implementation strategy are also met by the building code requirements.</p> <p>The City reaches out to the community providing information that will reduce energy costs to its customers.</p>	<p>Continue</p>
<p>HP-6.2: In order to reduce household transportation costs, the City will promote housing development in mixed-use settings near commercial and public services and in areas served by public transit.</p> <p>Timing: Ongoing through 2014</p> <p>Responsibility: Building Department</p>	<p>HIS 6.2: Continue to provide rebates for the installation and use of energy efficient appliances, insulation materials, windows, energy audits, weatherization, and other energy saving techniques.</p>	<p>Facilitate installation of energy efficient appliances in 20 units; facilitate energy efficiency retrofits in 10 units.</p>	<p>The City continues to implement this program by providing varying levels of rebates for various appliances.</p>	<p>This strategy is a continuing program of the city. Staff are developing a data base to quantify the number of rebates issued.</p> <p>The City amended its zoning code and supports mixed use in the downtown area.</p>	<p>Continue policy and implementation.</p>
<p>HP-6.1</p>	<p>HIS 6.3: The City will prepare a Nexus Fee Study and will update impact fees following adoption of the General Plan. The City’s Nexus Fee Study and update to impact fees should analyze energy procurement and distribution costs. The City will examine whether reduced impact fees would be appropriate and feasible for housing projects that include energy conservation techniques beyond those required by building codes</p>	<p>Induce energy efficiency investments in new housing development</p>	<p>The City conducted a nexus fee study and found that some of the recommendations to increase fees would be onerous at this time to implement due to the current economic downturn. The City wished to continue to keep fees as low as possible to encourage the continuation of construction in the City.</p>	<p>The fees that Gridley imposes are less than most other small municipalities. The decision to provide additional reduction in development, entitlement, and impact fees is not feasible at this time.</p>	<p>Delete</p>

Chapter 8: HOUSING PLAN

This chapter presents the City of Gridley's Housing Plan, outlining its goals, policies, and implementation strategies to achieve local, state, and regional objectives for housing.

Based on its past accomplishments, some of the previous programs were appropriate to support progress toward the State housing goal. Those that were not have been modified or combined with other programs to better meet the 2014-2022 Housing Element Goals and Policies.

The purpose and intent of Gridley's housing plan is to:

- ✓ Promote the preservation, improvement, and development of housing appropriate to meet the needs of the full range of household types and incomes.
- ✓ Encourage neighborhood stability and reinvestment in order to accommodate a variety of housing types and densities, as compatible with non-residential uses throughout the City.
- ✓ Ensure that new growth areas will accommodate a variety of housing that is planned and developed in coordination with nearby commercial and public services in the Planned Growth Area.
- ✓ Accommodate housing in both existing and new neighborhoods to serve for all socio-economic groups, a balance between homeownership and rental, multi-modal travel options, access to jobs, schools, and parks, and other civic and commercial services.

The City's housing strategies are important to achieving the City's overall economic, environmental, and social objectives, as described throughout the 2030 General Plan. The City's housing goal, policies, and implementation strategies are specifically drawn to compliment goals and policies in other elements of the new General Plan.

Please refer to the Land Use, Circulation, Open Space, Community Character and Design, and Public Facilities elements of the 2030 General Plan for other housing-related goals and policies.

GOALS, POLICIES, AND IMPLEMENTATION STRATEGIES

The housing plan is organized around the following key issues:

1. Housing Quality
2. Housing Quantity
3. Remove Constraints to Housing
4. Affordable Housing
5. Equal Housing Opportunity
6. Natural Resources and Energy Conservation

These build on the policies in the 2009-2014 Housing Element. They have been modified to reflect the successes Gridley has been able to accomplish.

CITY OF GRIDLEY, CALIFORNIA
Table 50 - 2014-2022 Housing Plan
Housing Policy and Implementation Strategies
(Govt. Code Section 65588)

Housing Policy	Housing Implementation Strategy (HIS)	Objective Quantified/Qualified
<p>HP-1.1: The City will maintain and enforce development standards and building standards that provide housing and safe neighborhoods for housing all income levels.</p> <p>Timing: 2015-2016</p> <p>Responsibility: Planning Department</p>	<p>HIS 1.1: On a request basis, the Building Department will continue to inspect buildings for Health and Safety Standards and Building Code violations. Buildings found in violation of Health and Safety Standards and/or Building Codes will be required to be rehabilitated to current Codes and Standards. Informational brochures shall be developed to inform residents of this service. The City will continue its current program to maintain a code violations database and notice property owners of code violations. The City will research options for addressing code violation problems with absentee property owners, including surveying other cities' approaches. The Planning Department will bring a recommendation and/or options for addressing this situation to the City Council for consideration and action, including, but not limited to revisions to the City's nuisance abatement procedures.</p>	<ol style="list-style-type: none"> 1. Analyze other city's programs and what programs are in place for absentee owners. 2. Provide information on the City website related to what a code violation is, what the community can do about nuisances, and what the abatement process is. 3. Update/develop a database of code violations.
<p>HP-1.2: The City will encourage the development and redevelopment of neighborhoods that include a variety of housing types and sizes.</p> <p>Timing: 2015-2016</p> <p>Responsibility: Planning Department</p>	<p>HIS 1.2: The City will analyze the results of the Housing Conditions Survey conducted in 2014 to help prioritize and apply the City's efforts and application of funding for housing rehabilitation.</p>	<ol style="list-style-type: none"> 1. Develop community outreach to encourage better exterior energy/aesthetic maintenance and loan programs for roofing, painting, and window replacement. 2. Outreach related to water conservation, better yard plantings that require less maintenance to improve general curb appeal.
<p>HP-1.3: The City will encourage the maintenance of existing housing to prevent deterioration and promote dwelling lifespan.</p> <p>Timing: Annually</p> <p>Responsibility: Planning Department</p>	<p>HIS 1.3: In coordination with the Regional Housing Authority of Sutter and Nevada Counties, the City will continue the Gridley Housing Rehabilitation Program to provide financial assistance to owner and renter lower-income households for housing rehabilitation during this planning cycle. The Housing Rehabilitation Program will be publicized in brochures made available at City Hall, the library, and electronically on the City's website.</p>	<ol style="list-style-type: none"> 1. Provide financial assistance to 30 owner and renter lower-income households for housing rehabilitation during this planning cycle. 2. The Housing Rehabilitation Program will be publicized in brochures, made available at City Hall, the library, and electronically on the City's website.

CITY OF GRIDLEY, CALIFORNIA
Table 50 - 2014-2022 Housing Plan
Housing Policy and Implementation Strategies
(Govt. Code Section 65588)

Housing Policy	Housing Implementation Strategy (HIS)	Objective Quantified/Qualified
		<p>3. An article will be published 2 x per year to inform the community of the opportunity to apply for housing rehabilitation funds.</p>
<p>HP- 2.1: The City will encourage infill development, through reduced or delayed payment of impact fees, priority in entitlement review, or other methods.</p> <p>Timing: Annually</p> <p>Responsibility: Planning Department</p>	<p>HIS 2.1: The Planning Department will prepare and maintain information on vacant infill properties designated by the City for urban development. The objective of this program is to make readily available data that is helpful to builders and land developers in preliminary research that could lead to redevelopment and infill development that forwards the City's planning goals. The City will survey builders, developers, and experts in real estate to determine the types of information that would be most helpful in making property investment decisions, and the City's property database should report on the same information as feasible. The information on vacant available properties could take the form of an online database or it could take other formats.</p>	<p>1. Provide data on the website depicting vacant sites that could be built upon.</p> <p>2. Provide data on the website related to building permits issued.</p> <p>3. Contact builders/agencies for site opportunities.</p>
<p>HP-2.2: The City will encourage the construction of second units within existing and proposed residential lots.</p> <p>Timing: Biannually, odd years</p> <p>Responsibility: Planning Department</p>	<p>HIS 2.2: The City will identify a range of incentives that could encourage development of vacant and underutilized properties in and near downtown Gridley. The City will specifically consider incentives that would encourage housing development, including affordable housing development. Develop a range of incentives to encourage development of vacant and underutilized properties in and near downtown Gridley. The City will survey builders and developers to determine which incentives would be most effective in inducing infill housing development. In surveying developers and builders, the City will make a specific effort to gather input from local developers and builders and those with experience developing affordable housing, multi-family housing, small lot single-family housing, and infill development of all types,. City staff will also collect and analyze relevant programs from other cities and counties that have had success with infill development. Staff will present City Council with options for incentives, which could include, but is not limited to reduction of fees, delay in payment of impact fees, reduced processing times for infill development consistent with the General Plan.</p>	<p>1. City staff would meet with developers informally or via telephone conferencing related to incentives for infill development and new housing opportunities.</p> <p>2. City staff will review programs developed in other cities of similar size that could be informative and provide innovative ideas that would stimulate development.</p>

CITY OF GRIDLEY, CALIFORNIA
Table 50 - 2014-2022 Housing Plan
Housing Policy and Implementation Strategies
(Govt. Code Section 65588)

Housing Policy	Housing Implementation Strategy (HIS)	Objective Quantified/Qualified
<p>HP-2.3: The City will encourage compact development, the use of drainage swales for stormwater conveyance, multi-use public facilities and lands, and other planning and design strategies to reduce the cost of infrastructure to serve new housing.</p> <p>Timing: 2015, 2016</p> <p>Responsibility: Planning Department</p>	<p>Based on this approval of changes to the Municipal Code or other necessary actions to create incentives for infill development, including infill housing development. The City will collect and analyze relevant programs from other cities and counties that have had successful infill development.</p> <p>HIS 2.3: The City will encourage the construction of second units housing to meet future housing needs in Gridley. The City will provide educational materials regarding second units to those seeking building permits for housing and those wishing to subdivide land for housing. The City will reduce development impact fees for second units, as necessary, to encourage their development. The City will follow adoption of a comprehensive General Plan Update with a Nexus Fee Study and Impact Fee Update. The City has described the intent for this program throughout the General Plan.</p> <p>The Fee Update will be tailored according to the City's infill and compact development objectives and affordable housing objectives. Please refer to the 2030 General Plan, including Public Facilities Implementation Strategy 1.2, Land Use Implementation Strategy 2.3, and Circulation Implementation Strategy 1.2 for more information.</p> <p>As a part of the Fee Update, the City will analyze the costs and public services demand for second units, and align impact fees to better represent actual public costs. For second units, development impact fees would be expected to be substantially lower than the typical single-family detached home.</p>	<p>1. Encourage production of at least 10 second units in this housing element planning horizon.</p> <p>2. The City will encourage second units to meet housing needs. Educational materials and community outreach will be conducted at least one time per year. Additionally, information will be placed on the City website.</p> <p>3. The City will revisit the Nexus Fee Study and Impact Fee update in 2016. A review of the previous recommendations will be considered if they are appropriate at that time.</p>
<p>HP-2.4: The City will encourage infill development in meeting the housing needs required by expanding populations.</p> <p>Timing: 2016, 2017</p> <p>Responsibility: Planning Department, Planning Commission, City Council</p>	<p>HIS 2.4: The City will consider a range of incentives to induce the rehabilitation of existing multi-family housing, adding bedrooms to existing housing, and conversion of existing nonresidential buildings to serve the needs of Gridley's larger families. The City will also encourage development of new rental housing that accommodates larger-household needs, providing more than 1- and 2-bedroom units.</p> <p>City staff will consult with local housing authorities on Gridley's desire to rehabilitate building to</p>	<p>1. Facilitate production of 3 larger rental units per year following the City Council's approved program implementation.</p> <p>2. Conduct community outreach for funding programs available that could be used to enlarge existing residences; newspapers, website,</p>

CITY OF GRIDLEY, CALIFORNIA
Table 50 - 2014-2022 Housing Plan
Housing Policy and Implementation Strategies
(Govt. Code Section 65588)

Housing Policy	Housing Implementation Strategy (HIS)	Objective Quantified/Qualified
	<p>provide multi-family housing with three or more bedrooms per unit.</p> <p>The City will consult with local housing authorities regarding applications for grant funding to rehabilitate housing, add a 3rd bedroom, and convert buildings for multi-family residential use.</p> <p>The City will consider collaborative development of a revolving loan program through a local housing authority, other public programs, or the City's Redevelopment Agency.</p> <p>City staff will report to the City Council a recommended set of actions to encourage rehabilitation of housing and conversion of existing nonresidential building stock for larger, multi-family housing. The City will revise the Municipal Code, fees, and standards, as appropriate, to provide the selected combination of incentives.</p>	<p>community meetings.</p> <p>3. Conduct outreach to the Builder's community to determine the viability of the conversion of large homes to multi-family homes.</p> <p>4. Continue partnering with local housing authorities.</p>
<p>HP-2.5: The City's infill and new growth housing incentives should be designed to achieve not only the City's housing goals, but also economic, social, and environmental goals of the City through programs identified in the 2030 General Plan.</p> <p>Timing: Annually</p> <p>Responsibility: Planning Department</p>	<p>HIS 2.5: City staff will consult with local developers to construct mixed use development with infill opportunities</p>	<p>1. Meet with developers to encourage the development of infill sites, mixed use developments, and housing renovation opportunities.</p>
<p>HP-2.6: The City will maintain adequate sites with appropriate zoning, development standards, access to public infrastructure and facilities needed to facilitate a variety of types of housing for the needs of all income levels and special needs groups, including rental housing, factory built or manufactured</p>	<p>HIS 2.6 The City shall review the zoning ordinance on an ongoing basis to determine its effectiveness in achieving the goals to the General Plan and its compliance with State Laws.</p> <p>Transitional, emergency, and support housing will be permitted as a residential use subject to restrictions that apply to other residential dwellings of the same type in the same zone.</p>	<p>1. The City will ensure the sites identified for development to meet RHNA allocation. Development standards shall be in conformance to the requirements at the time of development.</p> <p>2. The City shall encourage a mixture of income housing type with developments that are proposed.</p>

CITY OF GRIDLEY, CALIFORNIA
Table 50 - 2014-2022 Housing Plan
Housing Policy and Implementation Strategies
(Govt. Code Section 65588)

Housing Policy	Housing Implementation Strategy (HIS)	Objective Quantified/Qualified
<p>housing, mobile home, emergency shelters, and transitional housing.</p> <p>Timing: Annually</p> <p>Responsibility: Planning Department, Planning Commission, City Council</p>		
<p>HP-3.1: The City shall maintain a zoning ordinance, Municipal Code, and development review process that is free of constraints for development of housing to achieve the City's regional share of estimated future housing needs for all housing types and incomes.</p> <p>Timing: Annually</p> <p>Responsibility: Planning Department, Planning Commission, City Council</p>	<p>HIS 3.1: The City shall review the zoning ordinance on an ongoing basis to determine its effectiveness in achieving the goals to the General Plan and its compliance with State Laws.</p> <p>Transitional, emergency, and support housing will be permitted as a residential use subject to restrictions that apply to other residential dwellings of the same type in the same zone.</p>	<ol style="list-style-type: none"> 1. Ensure zoning achieves General Plan goals. 2. Ensure the zoning code is consistent with the Housing Plan Policies and the General Plan. 3. Amend the code to reflect transitional, emergency, and supportive housing as a residential use and to define one site that will allow emergency shelter on a year round basis. Refer to HP-3.3 and HP 3.4 below.
<p>HP-3.2</p> <p>Timing: Annually</p> <p>Responsibility: Planning Department, Planning Commission, City Council</p>	<p>HIS 3.2: The City will review the Housing Element on an annual basis to determine the effectiveness in achieving goals and objectives.</p> <p>The City will provide annual reports as to the implementation of the Housing Element to the Planning Commission, City Council, and the Department of Housing and Community Development, as required by Government Code Section 65400.</p> <p>The City will consider revisions to Housing Element programs, if necessary, to address issues of efficacy relative to goals and objectives.</p> <p>The City will monitor its development and processing/review procedures on an ongoing basis to minimize the time required for review by the City. The City will consider measures to reduce the plan review time needed by City staff by prioritizing review of permit applications for affordable housing projects, when proposed.</p>	<ol style="list-style-type: none"> 1. Ensure Housing Element is achieving goals and objectives. 2. Ensure City's design review and entitlement process does not impede higher-density housing and mixed-use development.
<p>HP-3.3</p>	<p>HIS 3.3: The City will amend the zoning ordinance</p>	<ol style="list-style-type: none"> 1. Amend the code to reflect

CITY OF GRIDLEY, CALIFORNIA
Table 50 - 2014-2022 Housing Plan
Housing Policy and Implementation Strategies
(Govt. Code Section 65588)

Housing Policy	Housing Implementation Strategy (HIS)	Objective Quantified/Qualified
<p>Timing: 2015</p> <p>Responsible Agency/Department: Planning Department, City Council.</p>	<p>to allow emergency shelters in the PQP and M-1 zone for year-round use without the need for a conditional use permit or other discretionary action. The City currently allows emergency shelters conditionally in the PQP zone. However, because there are a limited number of vacant sites with this zoning designation, emergency shelters will also be allowed by right in the M-1 zone, which has 17 acres of vacant land and additional land that would be considered underutilized.</p> <p>Transitional, emergency, and support housing will be permitted as a residential use subject to restrictions that apply to other residential dwellings of the same type in the same zone.</p>	<p>sites that can be used on a year round basis without requiring a use permit. 2. Evaluate the 2011 code amendment to ensure it meets the state legislation.</p> <p>3. Amend the code to reflect emergency housing as a residential use and to define one site that will allow emergency shelter on a year round basis.</p>
<p>HP-3.4</p> <p>Timing: 2015</p> <p>Responsible Agency/Department: Planning Department, City Council.</p>	<p>HIS 3.4: The City will amend the zoning ordinance to define and allow transitional and supportive housing in all residential zones, subject to the same development standards as would apply to a residential structure of the same housing type. The City may require a reasonable design review process for housing proposed to provide 7 or more units, or as required by the City's zoning ordinance for other types of higher-density housing. The City may require that operators provide evidence of applicable state licensing, where appropriate.</p>	<ol style="list-style-type: none"> Facilitate development of transitional and supportive housing. Comply with current state law requirements. Evaluate the 2011 code amendment to ensure it meets the state legislation. Amend the code to reflect transitional and supportive housing as a residential use and to define one site that will allow emergency shelter on a year round basis.
<p>HP-4.1: The City will promote the preservation of subsidized affordable housing developments.</p> <p>Timing: Annually</p> <p>Responsibility: Planning Department</p>	<p>HIS 4.1: The City will coordinate with the Butte County Housing Authority, Community Housing Improvement Program (CHIP), Regional Housing Authority of Sutter and Nevada Counties, and other non-profit affordable housing organizations, along with property owners of privately-owned, government-subsidized affordable housing projects to maintain the affordability status of affordable housing units in Gridley.</p> <p>The City will contact property owners of such affordable housing projects at least one year in advance of the date where properties could convert to market rate. The City will coordinate with area</p>	<ol style="list-style-type: none"> Preservation of affordable rental housing units.

CITY OF GRIDLEY, CALIFORNIA
Table 50 - 2014-2022 Housing Plan
Housing Policy and Implementation Strategies
(Govt. Code Section 65588)

Housing Policy	Housing Implementation Strategy (HIS)	Objective Quantified/Qualified
	<p>agencies and nonprofits to examine options for maintaining affordability status. The City will assist in identifying funds to maintain the affordability of rental units. If the owner expresses an interest in selling or converting their properties, the City will notify potential operators of subsidized affordable housing to determine interest in acquisition and operation of such properties, or will get assistance in seeking another interested investor or nonprofit housing corporation to acquire and continue operating the rental development for low-income households.</p>	
<p>HP-4.2: The City and will require replacement housing per state law (or relocation of displaced residents) within the housing rehabilitation projects for subsidized housing. Timing: Ongoing through 2014 Responsibility: Community Development Department</p>	<p>HIS 4.2: Contact possible sources of self-help housing, such as Community Housing Improvement Program (CHIP), the area housing authorities, or Habitat for Humanity. Coordinate with these groups to identify incentives or resources needed to facilitate self-help housing development. The City will consider incentives, such as fee reductions, delay in development impact fee payments and planning or zoning permit fees until occupancy, and streamlining of the entitlement review process to encourage development of self-help housing. The City will help promote the self-help housing to the public through information made available at City Hall and on the City's website.</p>	<p>1. Facilitate 5 new self-help housing units within the City by 2014.</p>
<p>HP-4.3: Seek and support housing needs of special groups such as seniors, handicapped persons, farmworkers, those in need of temporary shelter, single-parent families, and large families. Timing: Annually Responsibility: Planning Department</p>	<p>HIS 4.3: The City will coordinate with the Regional Housing Authority of Sutter and Nevada Counties to administer a First-Time Homebuyer Program.</p>	<p>1. Support first time homebuyers.</p>
<p>HP-4.4: Assist in the development of housing affordable to extremely low, very-low, and low-income households through financial and/or technical assistance to affordable housing developers.</p>	<p>HIS 4.4: The City will consult with local housing authorities and non-profits regarding opportunities for financing programs, such as mortgage credit and bond financing, as feasible, to provide assistance to lower- and moderate-income homebuyers and first-time homebuyers. The City will determine the feasibility of participating</p>	<p>1. Research funding mechanisms to increase for affordable housing projects. 2. Develop target activities that can be met.</p>

CITY OF GRIDLEY, CALIFORNIA
Table 50 - 2014-2022 Housing Plan
Housing Policy and Implementation Strategies
(Govt. Code Section 65588)

Housing Policy	Housing Implementation Strategy (HIS)	Objective Quantified/Qualified
<p>Timing: Report to City Council on discussions with other public agencies on the feasibility of consortiums for affordable housing bond financing by June 2016</p> <p>Responsibility: Planning Department, Finance Department</p>	<p>in a consortium with other public agencies to take advantage of tax- exempt bond financing for affordable housing and for assistance to lower- and moderate-income households. Feasibility will be based on the amount of funding that could be used within the City in relation to the cost of participation and the attractiveness of these certificates to first-time homebuyers. The City will also need to consider administrative capacity for any management responsibility for financing programs.</p> <p>The availability of financing for affordable housing should be advertised locally through brochures, quarterly newsletters, the City's website, local newspapers, civic buildings, and local finance agencies and real estate offices.</p>	
<p>HP-4.5: The City should proactively identify and apply for funding to expand affordable local housing opportunities.</p> <p>Timing: Meet annually or more frequently as appropriate.</p> <p>Responsibility: Planning Department, Finance Department</p>	<p>HIS 4.5: The City will cooperatively pursue funding for affordable housing projects with the Consolidated Area Housing Authority of Sutter County and the Butte County Housing Authority.</p> <p>A representative of the City will meet annually and additionally during the year as needed with representatives of each housing authority to determine their interest in, and plans for, constructing affordable housing in Gridley.</p> <p>The City will consult with the State Department of Housing and Community Development for assistance in identifying the most appropriate state and/or federal funding sources for the affordable housing most needed in Gridley and with the housing authorities to administer affordable housing development.</p>	<p>1.Pursue at least one funding opportunity for affordable housing construction every other year.</p>
<p>HP-5.1: Promote housing opportunities for all persons regardless of race, religion, sex, marital status, ancestry, national origin, or color.</p> <p>Timing: Ongoing</p> <p>Responsibility: Planning Department</p>	<p>HIS 5.1: The City will refer interested persons to the appropriate agencies, such as the Community Legal Information Center, Mediation Center of the North Valley, Butte County Housing Authority, and Legal Services of Northern California for assistance in fair housing matters.</p> <p>The City will act as an independent third-party to discrimination complaints, as they arise. The City will continue to provide informational fair housing brochures in English and Spanish available to the public at City Hall, the library, the U.S. Post Office, Butte County Family Services, Gridley Family Health Center, and on the City's website.</p>	<p>1. Assist in referral for fair housing matters.</p>
<p>HP-5.2: The City will encourage universal design</p>	<p>HIS 5.2: The City will adopt a written reasonable accommodation ordinance to provide exception in</p>	<p>1. Research a universal design ordinance for</p>

CITY OF GRIDLEY, CALIFORNIA
Table 50 - 2014-2022 Housing Plan
Housing Policy and Implementation Strategies
(Govt. Code Section 65588)

Housing Policy	Housing Implementation Strategy (HIS)	Objective Quantified/Qualified
<p>in new housing construction, as well as integration of accessibility features in existing housing structures</p> <p>The City will promote awareness of accessibility requirements and opportunities for builders, developers, and residents.</p> <p>Timing: End of 2015</p> <p>Responsibility: Planning Department</p>	<p>zoning and land-use for housing for persons with disabilities. This procedure will be a ministerial process, with minimal or no processing fee. Community Development Department staff will use the following or similar criteria in approving reasonable accommodations:</p> <p>The request for reasonable accommodation will be used by an individual with a disability protected under fair housing laws.</p> <p>The requested accommodation is necessary to make housing available to an individual with a disability protected under fair housing laws.</p> <p>The requested accommodation would not impose an undue financial or administrative burden on the City.</p> <p>The requested accommodation would not require a fundamental alteration in the nature of the City's land-use and zoning program.</p> <p>The City will either revise the Municipal Code or adopt stand-alone rules, policies, and procedures for reasonable accommodations. The City's procedures will specify exceptions to zoning and development standards and exceptions to building regulations needed to accommodate housing access for persons with disabilities. The City's amended procedures shall specific targeted timeframes for approval of reasonable accommodations.</p>	<p>adoption by City Council.</p>
<p>HP-6.1: In order to reduce long-term household utility costs, the City will promote new housing construction and retrofits designed to consume less energy, produce and use renewable energy, consume less water.</p> <p>Timing: Annually</p> <p>Responsibility: Building Department</p>	<p>HIS 6.1: Project applicants for building permits must show compliance with the state's energy conservation requirements at the time building plans are submitted.</p> <p>The Building Department will continue to be responsible for implementing the state's energy conservation standards. This includes checking of building plans and other written documentation showing compliance and the inspection of construction to ensure that the dwelling units are constructed according to those plans.</p>	<p>1.Ensure new development is designed to reduce ongoing building energy costs to future residents.</p>
<p>HP-6.2: In order to reduce household transportation costs, the City will promote housing development in mixed-use settings near</p>	<p>HIS 6.2: Continue to provide rebates for the installation and use of energy efficient appliances, insulation materials, windows, energy audits, weatherization, and other energy saving techniques.</p>	<p>1. Facilitate installation of energy efficient appliances in 20 units; facilitate energy efficiency retrofits in 10 units.</p>

CITY OF GRIDLEY, CALIFORNIA
Table 50 - 2014-2022 Housing Plan
Housing Policy and Implementation Strategies
(Govt. Code Section 65588)

Housing Policy	Housing Implementation Strategy (HIS)	Objective Quantified/Qualified
<p>commercial and public services and in areas served by public transit.</p> <p>Timing: Annually</p> <p>Responsibility: Building Department</p>		<p>2. Encourage energy efficiency investments in new housing development</p>
<p>HP-6.3: Consider Fee increases/decreases to stimulate development</p>	<p>HIS 6.3: The City will re-evaluate the 2011 Nexus Fee Study and will update impact fees if it appears the economy is stronger and could support it. The City's Nexus Fee Study and update to impact fees should analyze energy procurement and distribution costs. The City will examine whether reduced impact fees would be appropriate and feasible for housing projects that include energy conservation techniques beyond those required by building codes</p>	<p>1. Re-evaluate existing nexus study for adoption if appropriate.</p>

Quantified objectives

The California Government Code, Section 65583[b]) requires the Housing Element contain quantified objectives for the maintenance, preservation, improvement, and development of housing during the planning period. State law recognizes that the total housing needs as defined by the RHNA identified by a community may exceed available resources and the community's ability to satisfy this need. Under these circumstances, the quantified objectives need not be identical to the total housing needs, however, the quantified objectives shall establish the number of housing units by income category that can be realistically constructed, rehabilitated, and conserved over the eight-year planning period of June 15, 2014 to June 15, 2022.

The quantified objectives estimate the number of units likely to be constructed, rehabilitated or conserved/preserved by income level during the planning period. The quantified objectives do not represent a ceiling on development, but rather set a target goal for the jurisdiction to achieve based on needs, resources and constraints. The implementation of the quantified objectives is determined by actual funding available to the city and a developer's ability to construct during the slowed economic recovery experienced today and projected into the next 4 years. According to economic analysis for Congress, economic growth will continue to recover into 2017 and may flatten thereafter, further impacting the housing construction industry affecting the construction of affordable housing during the 2014-2022 planning period.

The city has shown adequate lands are available to meet the current housing allocation with a substantial reserve in place for future needs beyond 2022 noted above in Chapter 5, Housing Resources, Table 40 . The Housing Condition Survey-2014, Appendix 1, reviews the integrity of the housing stock in Gridley. The survey indicates that most residences exhibit structural integrity. The development of housing affordable for future residents may use CDBG or HOME funds for land write-downs to facilitate new construction rather than for rehabilitation loans.

The Construction objective refers to the number of new units that potentially may be constructed using public and/or private sources over the planning period of the element given the locality's land resources, constraints and proposed programs and represent the RHNA numbers.

The Rehabilitation objective refers to the number of existing units expected to be rehabilitated during the planning period.

The Conservation/Preservation objective refers to the preservation of the existing affordable housing stock throughout the planning period. A subset of the conservation objective is the number of federal, State and locally assisted at-risk units to be preserved.

Additionally, the city has included policy and programs in support of alternate affordable housing opportunities such as second units and self-help residential units.

Each quantified objective is detailed by income level as illustrated in the following table:

Table 51: Summary of Quantified Objectives: 2014-2022						
Income Level						
Program	Extremely Low	Very Low	Low	Moderate	Above Moderate	Objective
New Construction ¹	161	161	135	279	321	1,057
Rehabilitation ²		56	34	5	5	100
Conservation ³		5	5	5		15
<p>¹ New construction reflects the RHNA numbers for new and unmet needs for the City of Gridley as allocated by BCAG. Refer to Table 39, Units Under Construction or Approved. These developments are currently under construction and anticipate build-out by 2018, the midpoint of the planning period which includes 163 Above Moderate housing units.</p> <p>² Rehabilitation of units are for senior housing "The Oaks" (56) and "Evergreen Assisted Living"(34). 10 units for Moderate and Above Moderate are homes identified in the Housing Condition Survey - 2014 that need improvements.</p> <p>³Conservation of units would be funded to improve single family homes in acute disrepair that might be lost should repairs not be made as identified in the Housing Condition Survey-2014</p>						
Affordable Housing						
HP-2.3	The city will encourage the construction of second units to meet future housing needs in Gridley.				▪ Encourage the production of 10 second units.	
HP-4.1	The city will promote the preservation of subsidized affordable housing developments.				▪ Coordinate with RHASNC for funding opportunities to maintain affordable units	
HP-4.2	The city will contact sources of self-help housing and help coordinate resources.				▪ Facilitate 5 new self-help housing units by 2022.	
HP-4.3	The city will coordinate with RHASNC to administer a First-Time Homebuyer Program				▪ Support first time home buyer programs.	